

Count	Description
1	<p data-bbox="225 338 596 360">TPE3 50-150 S-A-G-I-BQQE-FCB</p> <div data-bbox="295 383 536 701">  </div> <p data-bbox="619 685 1062 707">Product photo could vary from the actual product</p> <p data-bbox="225 719 488 741">Product No.: 98819649</p> <p data-bbox="225 779 1452 853">Single-stage, close-coupled, volute pump with in-line suction and discharge ports of identical diameter. The pump is of the top-pull-out design, i.e. the power head (motor, pump head and impeller) can be removed for maintenance or service while the pump housing remains in the pipework.</p> <p data-bbox="225 864 1238 887">The shaft seal is according to EN 12756. Pipework connection is via CLASS 150 ANSI flanges.</p> <p data-bbox="225 898 1430 943">The pump is fitted with a fan-cooled, permanent-magnet synchronous motor. The motor efficiency is classified as IE5 in accordance with IEC 60034-30-2.</p> <p data-bbox="225 954 1430 999">The motor includes a frequency converter and PI controller in the motor terminal box. This enables continuously variable control of the motor speed, which again enables adaptation of the performance to a given requirement.</p> <p data-bbox="225 1010 1374 1055">The pump is fitted with a combined temperature- and differential-pressure sensor. The stainless-steel pump housing makes the pump suitable for circulation of hot water.</p> <p data-bbox="225 1093 1445 1122">The pump is suitable for applications requiring pressure or temperature control and offers following control modes:</p> <ul data-bbox="264 1155 1445 1547" style="list-style-type: none"> - AUTOADAPT. This function continuously adjusts the proportional-pressure curve and automatically sets a more efficient curve without compromising comfort demands. - FLOWADAPT. This control mode combines AUTOADAPT with a flow-limiting function. The pump continuously monitors the flow rate to ensure the desired maximum flow is not exceeded. This will save the cost of a separate pump-throttling valve. - Constant differential pressure. The pump head is kept constant, independent of the flow in the system. - Proportional pressure. The head of the pump will increase proportionally to the flow in the system to compensate for the large pressure losses in the distribution pipes. - Constant temperature. The return-pipe temperature is kept constant. Note: If the pump is intalled in the flow pipe, an external temperature sensor must be installed in the return pipe of the system. - Constant differential temperature. The differential temperature can be measured by a differential-temperature sensor or two separate temperature sensors. - Constant curve. The pump can be set to run at a constant speed in the range of 25 to 100 % of the maximum speed. <p data-bbox="225 1559 1414 1603">The operating panel on the motor terminal box features a four-inch TFT display, push-buttons and the Grundfos Eye indicator.</p> <p data-bbox="225 1648 983 1671">The display gives an intuitive and user-friendly interface to all functions.</p> <p data-bbox="225 1682 1430 1727">The push-buttons are used to navigate through the menu structure to access pump and performance data on site and enable setting of required setpoint as well as setting of pump to "Min." or "Max." operation or to "Stop".</p> <p data-bbox="225 1794 1452 1861">Communication with the pump is also possible by means of Grundfos GO Remote (accessory). The remote control enables further settings as well as reading out of a number of parameters such as "Actual value", "Speed", "Power input" and total "Power consumption".</p> <p data-bbox="225 1906 1214 1928">The Grundfos Eye indicator on the operating panel provides visual indication of pump status:</p> <ul data-bbox="264 1939 1414 2074" style="list-style-type: none"> • "Power on": Motor is running (rotating green indicator lights) or not running (permanently green indicator lights) • "Warning": Motor is still running (rotating yellow indicator lights) or has stopped (permanently yellow indicator lights) • "Alarm": Motor has stopped (flashing red indicator lights).

Count	Description
	<p>Cast-iron parts have an epoxy-based coating made in a cathodic electro-deposition (CED) process. CED is a high-quality dip-painting process where an electrical field around the products ensures deposition of paint particles as a thin, well-controlled layer on the surface.</p> <p>Pump</p>  <p>1: Pump housing 2: Impeller 3: Neck ring 4: Pump head/motor stool 5: Stub shaft</p> <p>The pump housing is provided with a replaceable stainless steel/PTFE neck ring to reduce the amount of liquid running from the discharge side of the impeller to the suction side. The impeller is secured to the shaft with a nut.</p> <p>The pump is fitted with an unbalanced rubber bellows seal with torque transmission across the spring and around the bellows. Due to the bellows, the seal does not wear the shaft, and the axial movement is not prevented by deposits on the shaft.</p> <p>Primary seal:</p> <ul style="list-style-type: none"> • Rotating seal ring material: silicon carbide (SiC) • Stationary seat material: silicon carbide (SiC) <p>This material pairing is used where higher corrosion resistance is required. The high hardness of this material pairing offers good resistance against abrasive particles.</p> <p>Secondary seal material: EPDM (ethylene-propylene rubber) EPDM has excellent resistance to hot water. EPDM is not suitable for mineral oils.</p> <p>The motor stool forms connection between the pump housing and the motor, and is equipped with a manual air vent screw for venting of the pump housing and the shaft seal chamber. The sealing between motor stool and pump housing is an O-ring.</p> <p>The central part of the motor stool is provided with guards for protection against the shaft and coupling. Motor and pump shaft are connected via a rigid sleeve coupling.</p> <p>Motor</p> <p>The motor is a totally enclosed, fan-cooled motor with principal dimensions to IEC and DIN standards. Electrical tolerances comply with IEC 60034.</p> <p>The motor efficiency is classified as IE5 in accordance with IEC 60034-30-2.</p> <p>The motor requires no external motor protection. The motor control unit incorporates protection against slow- and quick-rising temperatures, e.g. constant overload and stalled conditions.</p> <p>The terminal box holds terminals for these connections:</p> <ul style="list-style-type: none"> - one dedicated digital input - two analog inputs, 0(4)-20 mA, 0-10 V - one configurable digital input or open-collector output - Grundfos combined temperature and differential pressure sensor (separate connected) - 24 V voltage supply for sensors - two signal relay outputs (potential-free contacts) - GENIbus connection - interface for Grundfos CIM fieldbus module. <p>Further product details</p> <p>Technical data</p>

Count	Description
	<p>Controls:</p> <p>Frequency converter: Built-in</p> <p>Liquid:</p> <p>Pumped liquid: Water</p> <p>Liquid temperature range: -13 .. 248 °F</p> <p>Selected liquid temperature: 68 °F</p> <p>Density: 62.29 lb/ft³</p> <p>Technical:</p> <p>Rated pump speed: 3800 rpm</p> <p>Rated flow: 100 US gpm</p> <p>Rated head: 31.17 ft</p> <p>Actual impeller diameter: 2.91 in</p> <p>Code for shaft seal: BQQE</p> <p>Curve tolerance: ISO9906:2012 3B2</p> <p>Materials:</p> <p>Pump housing: Stainless steel EN 1.4308 ASTM CF8</p> <p>Impeller: Composite PES+30% GF</p> <p>Installation:</p> <p>Range of ambient temperature: -4 .. 122 °F</p> <p>Maximum operating pressure: 232.06 psi</p> <p>Max pressure at stated temperature: 232 psi / 250 °F</p> <p>Type of connection: ANSI</p> <p>Size of connection: DN 50</p> <p>Pressure rating for connection: CLASS 150</p> <p>Port-to-port length: 11 1/16 in</p> <p>Flange size for motor: 56C</p> <p>Electrical data:</p> <p>Motor type: 80A</p> <p>IE Efficiency class: IE5</p> <p>Rated power - P2: 1 HP</p> <p>Main frequency: 60 Hz</p> <p>Rated voltage: 3 x 440-480 V</p> <p>Rated current: 1.65 A</p> <p>Cos phi - power factor: 0.73</p> <p>Rated speed: 360-4000 rpm</p> <p>IE efficiency: 86.4%</p> <p>Motor efficiency at full load: 86.4 %</p> <p>Enclosure class (IEC 34-5): IP55</p> <p>Insulation class (IEC 85): F</p> <p>Motor Number: 99630342</p> <p>Others:</p> <p>Net weight: 58.7 lb</p> <p>Gross weight: 74.5 lb</p> <p>Shipping volume: 3.53 ft³</p> <p>Country of origin: HU</p> <p>Custom tariff no.: 8413.70.2022</p>

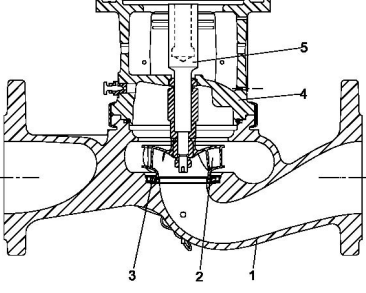

Company name:

Created by:

Phone:

Date:

1/22/2022

98819649 TPE3 50-150 S-A-G-I-BQQE-FCB 60 Hz

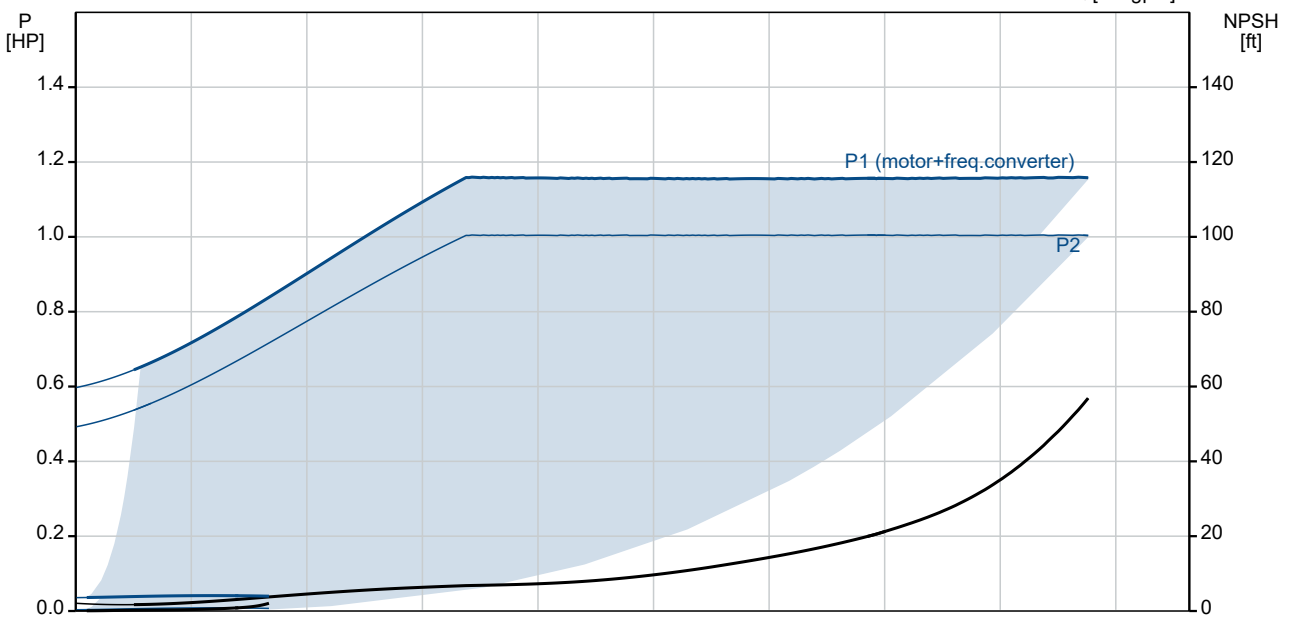
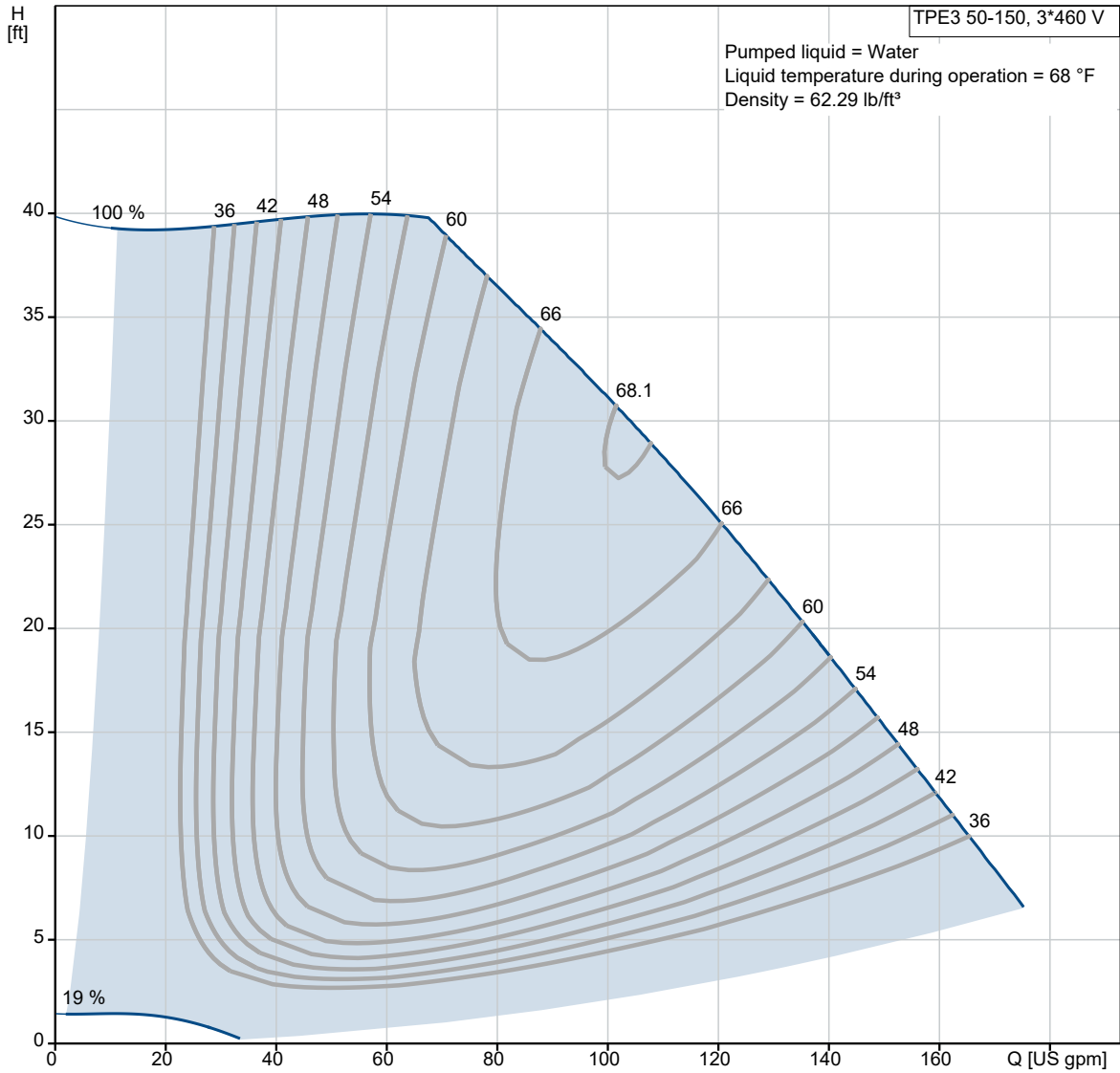

Description	Value
General information:	
Product name:	TPE3 50-150 S-A-G-I-BQQE-FCB
Product No.:	98819649
EAN:	5712601844338
Technical:	
Rated pump speed:	3800 rpm
Rated flow:	100 US gpm
Rated head:	31.17 ft
Maximum head:	49.22 ft
Actual impeller diameter:	2.91 in
Code for shaft seal:	BQQE
Curve tolerance:	ISO9906:2012 3B2
Pump version:	A
Materials:	
Pump housing:	Stainless steel
Pump housing:	EN 1.4308
Pump housing:	ASTM CF8
Impeller:	Composite
Impeller:	PES+30% GF
Material code:	I
Installation:	
Range of ambient temperature:	-4 .. 122 °F
Maximum operating pressure:	232.06 psi
Max pressure at stated temperature:	232 psi / 250 °F
Type of connection:	ANSI
Size of connection:	DN 50
Pressure rating for connection:	CLASS 150
Port-to-port length:	11 1/16 in
Flange size for motor:	56C
Connect code:	G
Liquid:	
Pumped liquid:	Water
Liquid temperature range:	-13 .. 248 °F
Selected liquid temperature:	68 °F
Density:	62.29 lb/ft³
Electrical data:	
Motor type:	80A
IE Efficiency class:	IE5
Rated power - P2:	1 HP
Main frequency:	60 Hz
Rated voltage:	3 x 440-480 V
Rated current:	1.65 A
Cos phi - power factor:	0.73
Rated speed:	360-4000 rpm
IE efficiency:	86.4%
Motor efficiency at full load:	86.4 %
Enclosure class (IEC 34-5):	IP55
Insulation class (IEC 85):	F
Built-in motor protection:	ELEC
Motor Number:	99630342
Controls:	
Control panel:	HMI300 - Graphical
Function Module:	FM300 - Advanced
Frequency converter:	Built-in
Others:	
Net weight:	58.7 lb
Gross weight:	74.5 lb

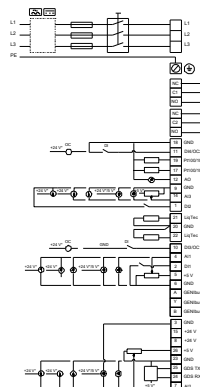
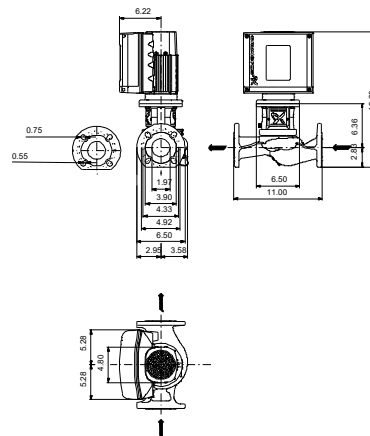
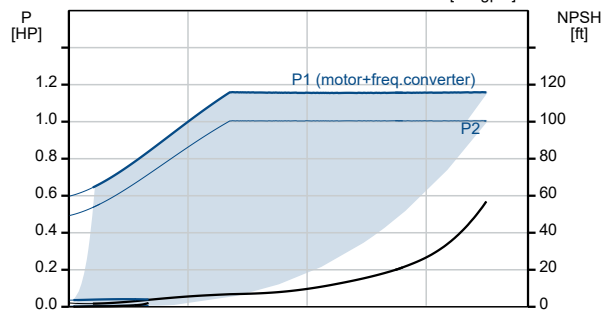
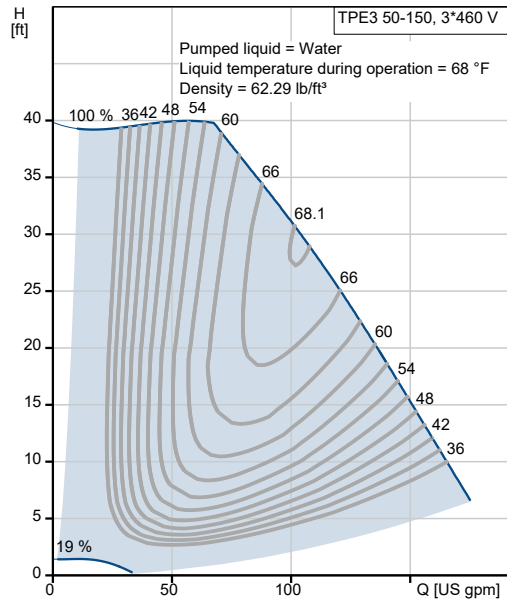



Company name:

Created by:

Phone:

Date:

1/22/2022

Description	Value
Shipping volume:	3.53 ft ³
Config. file no:	98484782
Country of origin:	HU
Custom tariff no.:	8413.70.2022

98819649 TPE3 50-150 S-A-G-I-BQQE-FCB 60 Hz

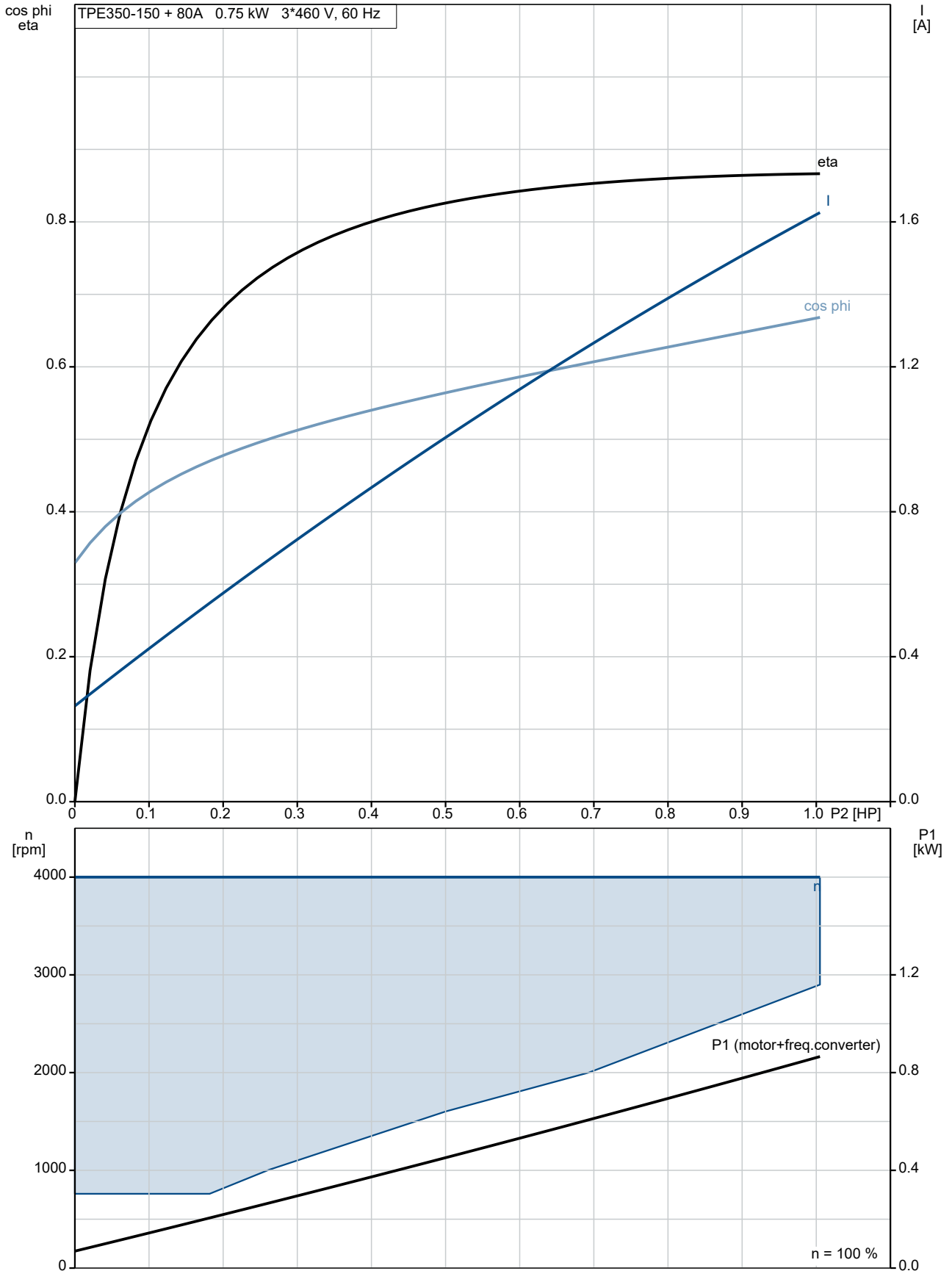

98819649 TPE3 50-150 S-A-G-I-BQQE-FCB 60 Hz

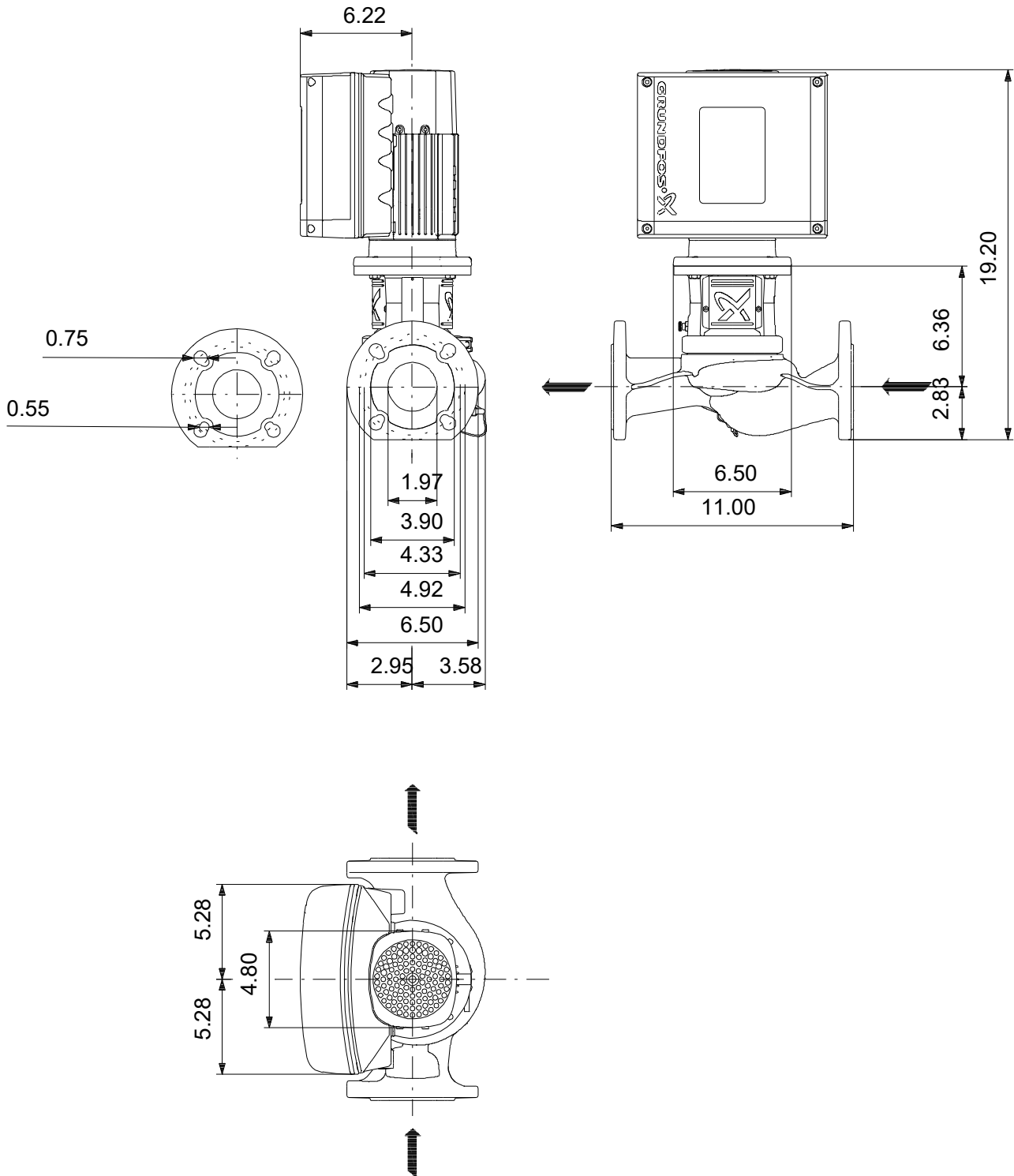

Note! All units are in [in] unless otherwise stated.
 Disclaimer: This simplified dimensional drawing does not show all details.

98819649 TPE3 50-150 S-A-G-I-BQQE-FCB 60 Hz



All units are [in] unless otherwise presented.