

PROJECT: _____	UNIT TAG: _____	QUANTITY: _____
REPRESENTATIVE: _____	TYPE OF SERVICE: _____	DATE: _____
ENGINEER: _____	SUBMITTED BY: _____	DATE: _____
CONTRACTOR: _____	APPROVED BY: _____	DATE: _____
	ORDER NO.: _____	DATE: _____



UPS 26-150 F

UPS is a three-speed circulator pump designed for heating and air-conditioning systems and is also used for central and district heating systems. The pump provides reliable and maintenance-free operation.

Note! Product picture may differ from actual product

Conditions of Service		Pump Data		Motor Data	
Liquid:	Water	Liquid temperature range:	35.6 .. 230 °F	Max. power input:	370 W
Temperature:	140 °F	Maximum ambient temperature:	104 °F	Mains frequency:	60 Hz
Specific Gravity:	0.985	Pipe connection:	2-BOLT FLANGE	Thermal protection:	internal
		Product number:	95906630		

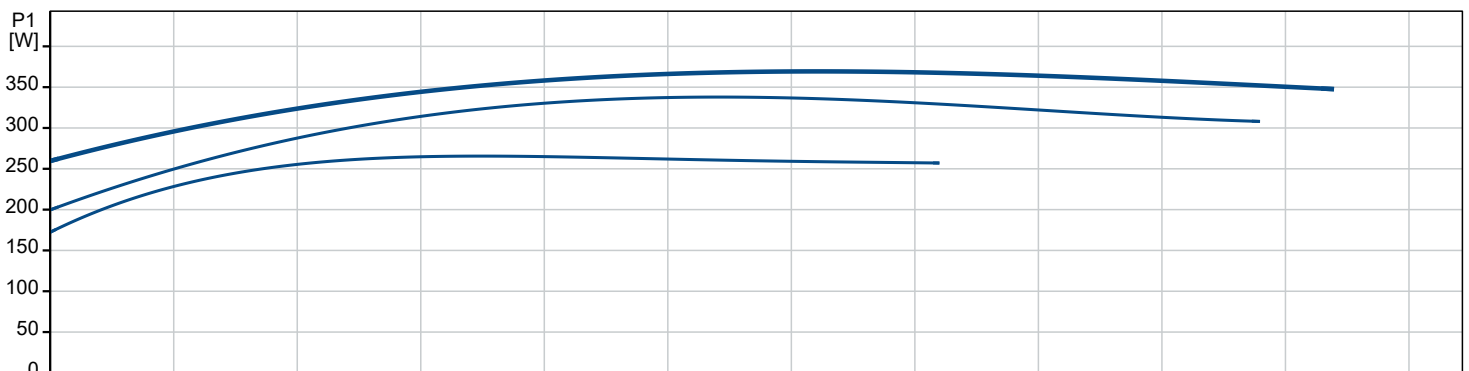
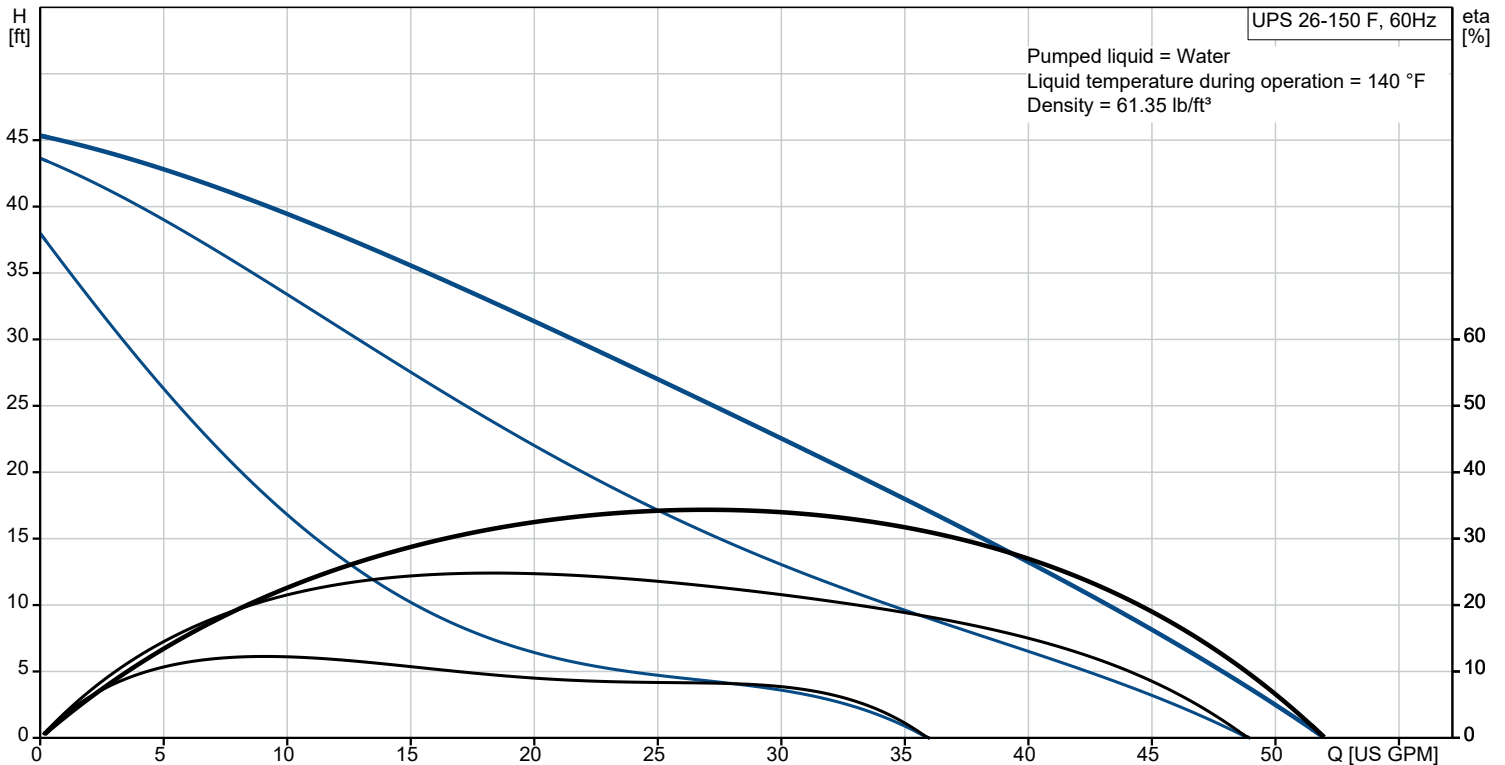

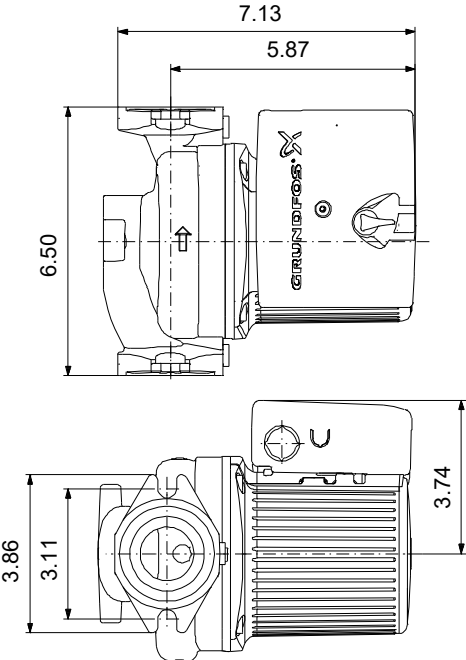

Materials:
Pump housing: Cast iron
Pump housing: ASTM A48-30B
Impeller: Composite

Qty.	Description
------	-------------

1

UPS 26-150 F

Product No.: [95906630](#)

The pump is of the canned rotor type, i.e. pump and motor form an integral unit without shaft seal and with only two gaskets for sealing.

The bearings are lubricated by the pumped liquid.

The pump has 3-step speed selector.

The pump is characterized by:

- * Ceramic shaft and radial bearings.
- * Carbon axial bearing.
- * Stainless steel rotor can and bearing plate.
- * Corrosion-resistant impeller, Composite.
- * Cast iron pump housing.

The motor is a 1-phase motor.

No additional motor protection is required.

Liquid:

Pumped liquid: Water
Liquid temperature range: 35.6 .. 230 °F
Selected liquid temperature: 140 °F
Density: 61.35 lb/ft³

Technical:

Rated flow: 26.9 US GPM
Max flow: 52 US GPM
Rated head: 25.37 ft
Approvals: CETL

Materials:

Pump housing: Cast iron
EN 1561 EN-GJL-200
ASTM A48-30B
Impeller: Composite
PES+30% GF

Installation:

Max. ambient: 104 °F
Amb. max at 80 dgr C liquid: 176 °F
Maximum operating pressure: 145.04 psi
Type of connection: OVAL
Pipe connection: 2-BOLT FLANGE
Pressure rating for connection: PN 10
Port-to-port length: 6 1/2 in

Electrical data:

Power input in speed 1: 0.3554 HP
Power input in speed 2: 335 W
Max. power input: 370 W
Mains frequency: 60 Hz
Rated voltage: 1 x 115 V
Current in speed 1: 2.5 A
Current in speed 2: 3.1 A
Current in speed 3: 3.5 A
Capacitor size - run: 40 µF/180 V
Number of poles: 2
Insulation class (IEC 85): H
Built-in motor protection: CONTACT

Others:

Terminal box position: 9H
Net weight: 13.9 lb
Gross weight: 15.2 lb

95906630 UPS 26-150 F 60 Hz

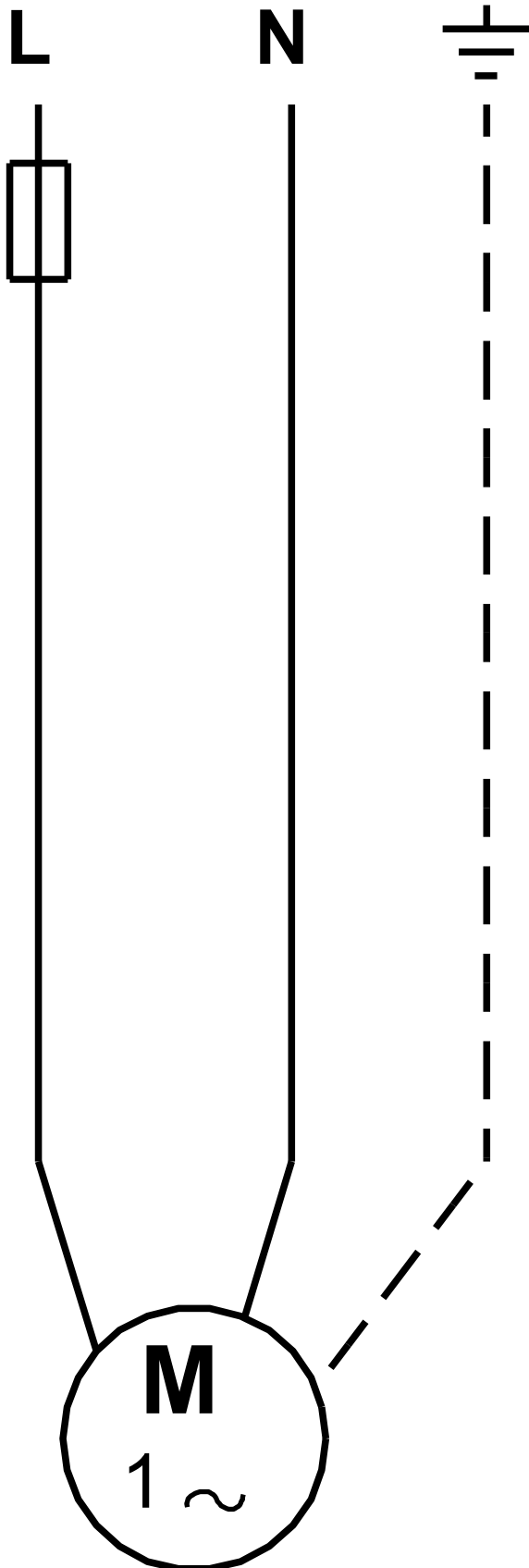

Note! All units are in [in] unless others are stated.