

PROJECT: _____	UNIT TAG: _____	QUANTITY: _____
REPRESENTATIVE: _____	TYPE OF SERVICE: _____	DATE: _____
ENGINEER: _____	SUBMITTED BY: _____	DATE: _____
CONTRACTOR: _____	APPROVED BY: _____	DATE: _____
	ORDER NO.: _____	DATE: _____



UP 53-46 F

UP is a single-speed circulator pump designed for domestic heating systems. The pump provides reliable and maintenance-free operation as well as low energy consumption throughout its long lifespan.

Note! Product picture may differ from actual product

Conditions of Service		Pump Data		Motor Data	
Efficiency:	%	Liquid temperature range:	14 .. 230 °F	Max. power input:	420 W
Liquid:	Water	Maximum ambient temperature:	104 °F	Rated voltage:	115-230 V
Temperature:	140 °F	Pipe connection:	GF 53	Mains frequency:	60 Hz
NPSH required:	ft	Product number:	96633591	Enclosure class:	X4D
Specific Gravity:	0.985			Thermal protection:	internal

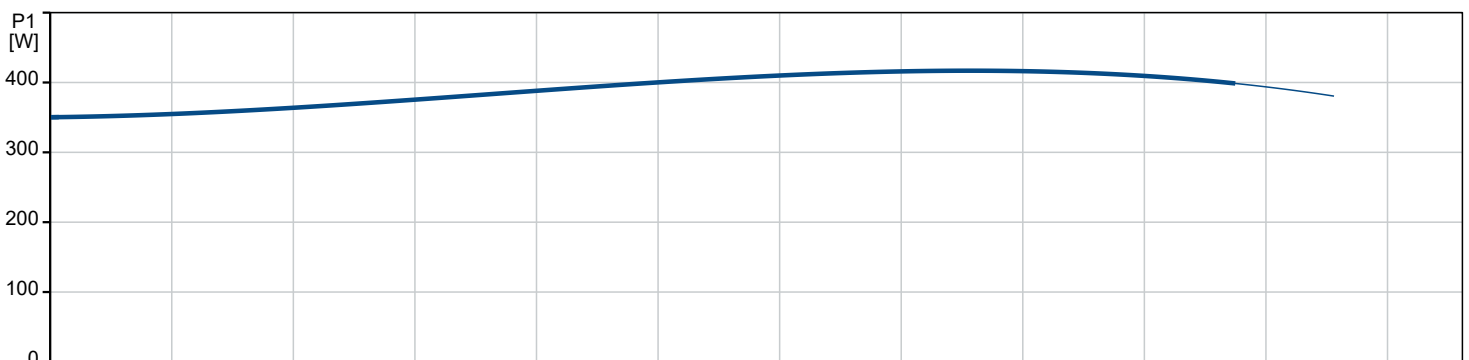
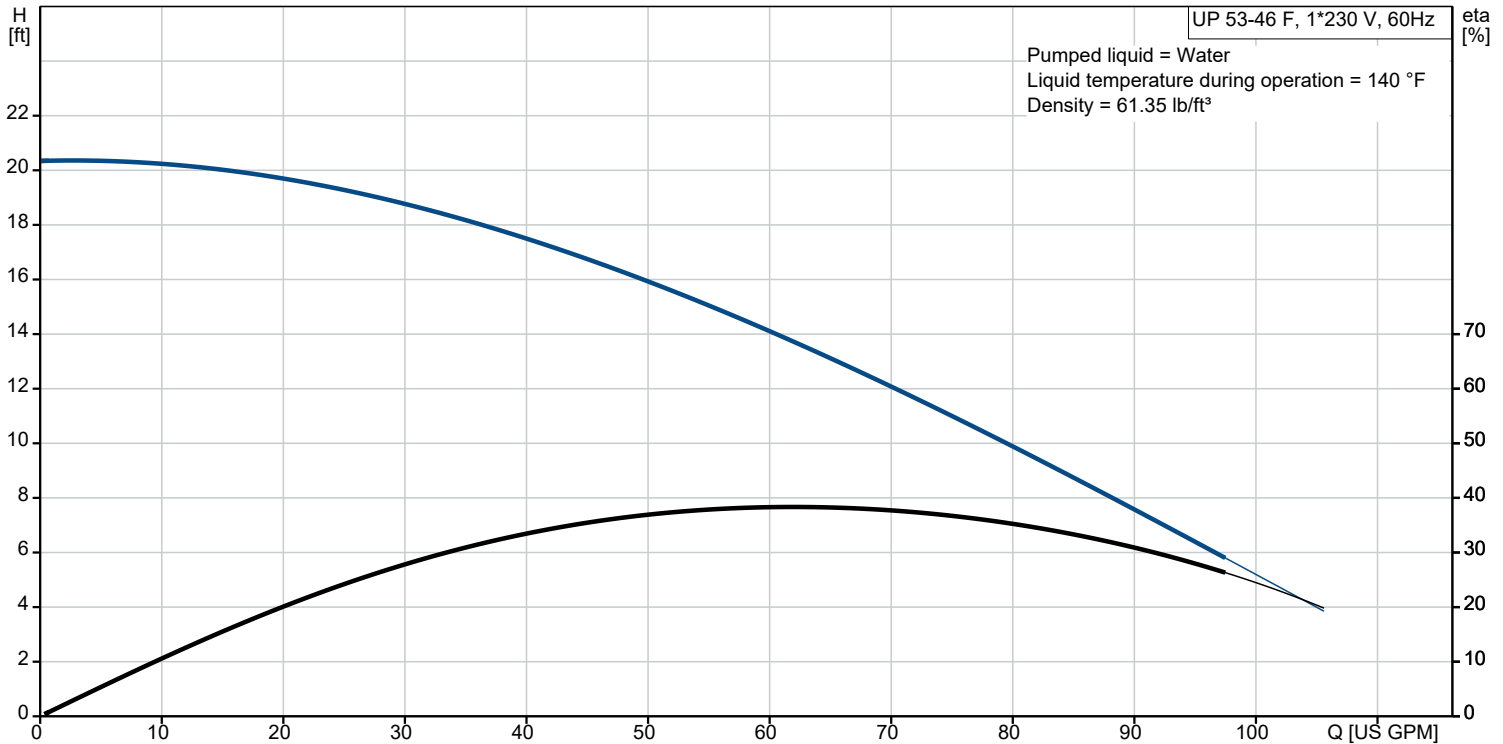

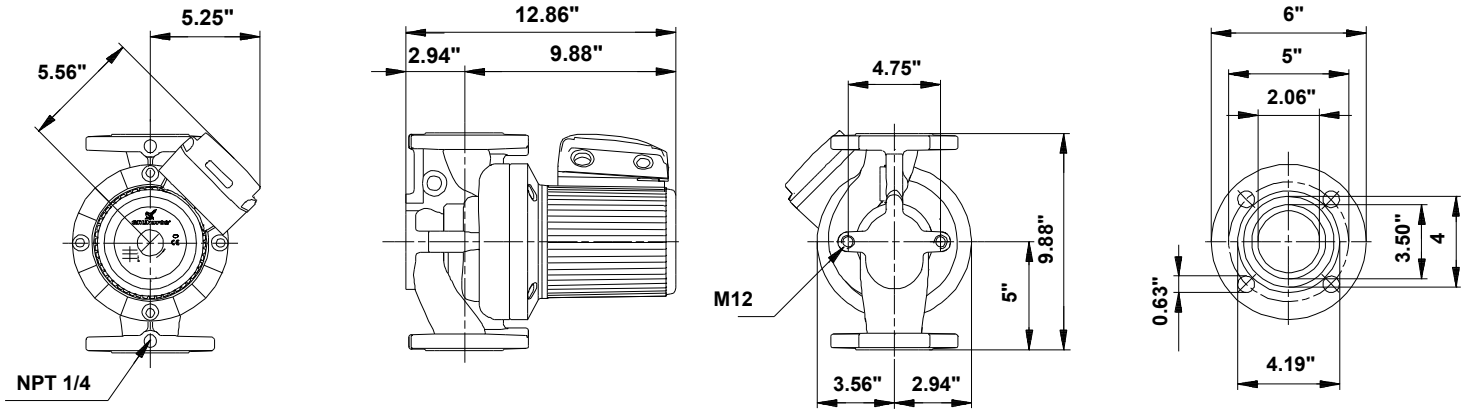

Materials:

- Pump housing: Cast iron
- Pump housing: ASTM 35 B - 40 B
- Impeller: Stainless steel
- Impeller: AISI 304
- Impeller: EN 1.4301

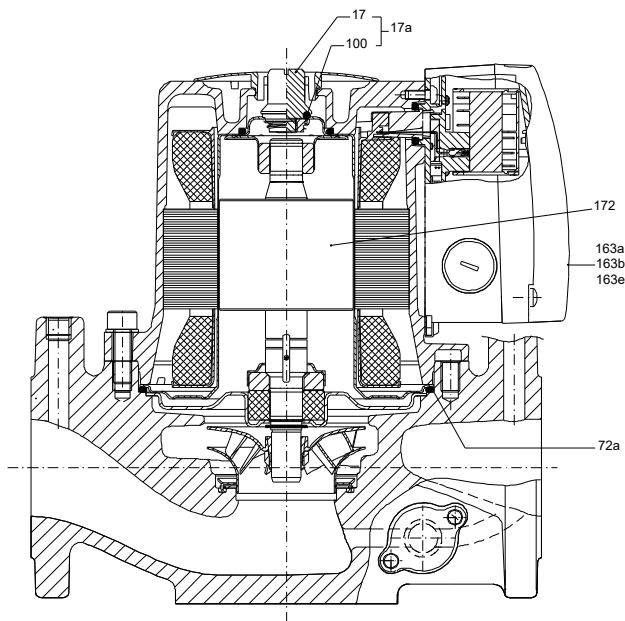

Qty.	Description
1	<p>UP 53-46 F Product No.: 96633591 The pump is of the canned rotor type, i.e. pump and motor form an integral unit without shaft seal and with only two gaskets for sealing. The bearings are lubricated by the pumped liquid.</p> <p>In order to avoid problems in connection with disposal, great importance has been attached to using as few different materials as possible. The pump is characterized by:</p> <ul style="list-style-type: none"> * 1 speed motor. * Ceramic radial bearings. * Carbon axial bearing. * Stainless steel rotor can, bearing plate and rotor cladding. * Aluminium alloy stator housing. * Cast iron pump housing. * Stator with built-in thermal switch. <p>The motor is a 1-phase motor.</p> <p>The pump is supplied with a standard module in the terminal box. The standard module is to be connected to the mains supply via external contactor.</p> <p>Controls:</p> <p>Relay: with relay</p> <p>Liquid:</p> <p>Pumped liquid: Water Liquid temperature range: 14 .. 230 °F Selected liquid temperature: 140 °F Density: 61.35 lb/ft³</p> <p>Technical:</p> <p>Approvals: CCSAUS</p> <p>Materials:</p> <p>Pump housing: Cast iron EN 1561 EN-GJL-250 ASTM 35 B - 40 B</p> <p>Impeller: Stainless steel EN 1.4301 AISI 304</p> <p>Installation:</p> <p>Range of ambient temperature: 32 .. 104 °F Maximum operating pressure: 145.04 psi Type of connection: DIN Pipe connection: GF 53 Pressure rating for connection: PN 10 Port-to-port length: 9 7/8 in</p> <p>Electrical data:</p> <p>Max. power input: 420 W Mains frequency: 60 Hz Rated voltage: 1 x 115-230 V Current in speed 3: 3.9/2.1 A Cos phi: 0.90 Capacitor size - run: 50 µF/240 V Enclosure class (IEC 34-5): X4D Insulation class (IEC 85): F</p>



Company name: Hurley Engineering

Created by:

Phone:

Date: 23/02/2023

Qty.	Description
1	<p data-bbox="111 253 1560 291">Built-in motor protection: CONTACT</p> <p data-bbox="111 313 1560 347">Others:</p> <p data-bbox="111 347 1560 380">Terminal box position: 1.30H</p> <p data-bbox="111 380 1560 414">Net weight: 44.5 lb</p> <p data-bbox="111 414 1560 448">Gross weight: 52.5 lb</p> <p data-bbox="111 448 1560 481">Shipping volume: 2.12 ft³</p>