

PROJECT: _____	UNIT TAG: _____	QUANTITY: _____
REPRESENTATIVE: _____	TYPE OF SERVICE: _____	DATE: _____
ENGINEER: _____	SUBMITTED BY: _____	DATE: _____
CONTRACTOR: _____	APPROVED BY: _____	DATE: _____
	ORDER NO.: _____	DATE: _____



SEG.A15.20.R1.2.1.603

Submersible Grundfos SEG sewage grinder pumps (0.9-4 kW) are designed for pumping wastewater, sludge-containing water, and sewage. Fitted with a patented grinder system designed to grind the media.

Note! Product picture may differ from actual product

Conditions of Service	Pump Data	Motor Data
Efficiency: %	Maximum operating pressure: 6 bar	Rated voltage: 208-230 V
Liquid: Any Newtonian liquid	Liquid temperature range: 0 .. 40 °C	Mains frequency: 60 Hz
NPSH required: m	Maximum ambient temperature: 40 °C	Number of poles: 2
Specific Gravity: 1.000	Approvals: PA-I	Enclosure class: IP68
	Flange standard: ANSI	Insulation class: F
	Product number: 98682359	Motor protection: THERMAL SWITCH
		Thermal protection: external

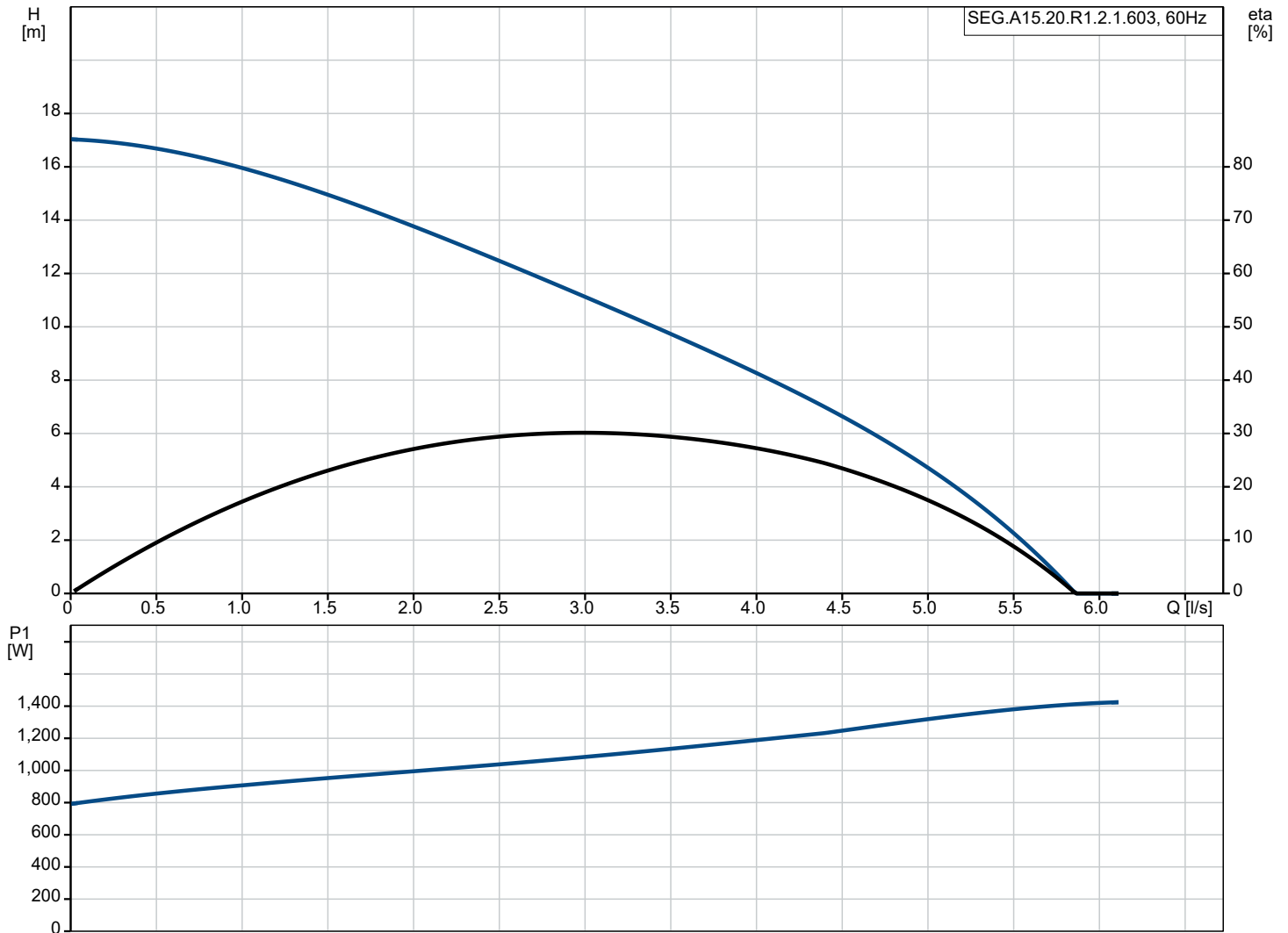

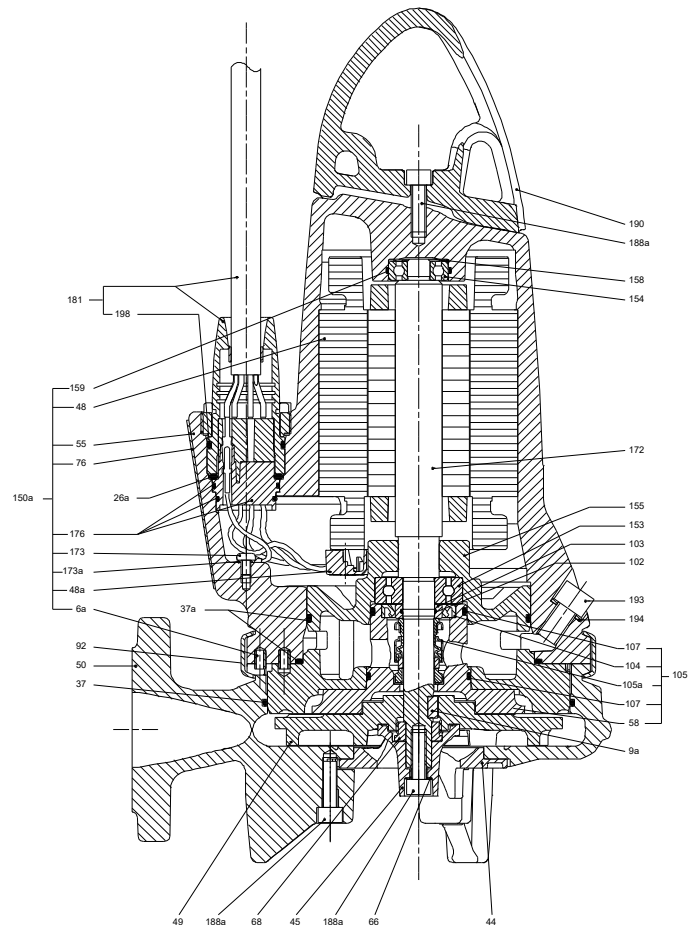
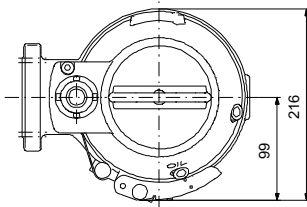
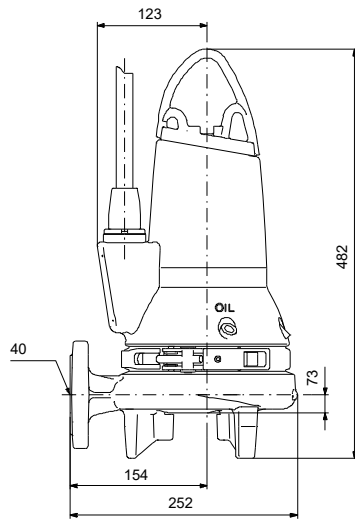

Materials:

- Pump housing: Cast iron
- Pump housing: EN1561 EN-GJL-200
- Pump housing: ASTM ASTM A48 30B
- Impeller: Cast iron
- Impeller: EN1561 EN-GJL-200
- Impeller: ASTM ASTM A48 30B

Description	Value
General information:	
Product name:	SEG.A15.20.R1.2.1.603
Product No:	98682359
EAN number:	5711499540353
Technical:	
Max flow:	6.11 l/s
Max flow:	6.11 l/s
Head max:	17 m
Type of impeller:	Grinder system
Primary shaft seal:	SIC/SIC
Approvals on nameplate:	PA-I
Curve tolerance:	ANSI/HI11.6:2017 3B2
Materials:	
Pump housing:	Cast iron
Pump housing:	EN1561 EN-GJL-200
Pump housing:	ASTM ASTM A48 30B
Impeller:	Cast iron
Impeller:	EN1561 EN-GJL-200
Impeller:	ASTM ASTM A48 30B
Installation:	
t max amb:	40 °C
Maximum operating pressure:	6 bar
Flange standard:	ANSI
Pipework connection:	1 1/2" /2"
Size of outlet connection:	1 1/2 inch
Pressure rating:	PN 10
Maximum installation depth:	10 m
Inst dry/wet:	SUBMERGED
Auto-coupling:	98245788
Liquid:	
Pumped liquid:	Any Newtonian liquid
Liquid temperature range:	0 .. 40 °C
Density:	998.2 kg/m ³
Electrical data:	
Power input - P1:	1.6 kW
Rated power - P2:	1.2 kW
Mains frequency:	60 Hz
Rated voltage:	1 x 208-230 V
Voltage tolerance:	+6/-10 %
Max starts per. hour:	30
Rated current:	9-8 A
Starting current:	48 A
Rated current at no load:	7.2 A
Cos phi - power factor:	0.91
Cos phi - p.f. at 3/4 load:	0.82
Cos phi - p.f. at 1/2 load:	0.8
Rated speed:	3450 rpm
Moment of inertia:	0.002 kg m ²
Motor efficiency at full load:	74 %
Motor efficiency at 3/4 load:	73 %
Motor efficiency at 1/2 load:	66 %
Capacitor size - run:	40 µF
Capacitor size - start:	150 µF
Number of poles:	2
Start. method:	direct-on-line
Enclosure class (IEC 34-5):	IP68
Insulation class (IEC 85):	F
Explosion proof:	no
Ex-description:	WITHOUT (STANDARD)
Built-in motor protection:	THERMAL SWITCH
Thermal protec:	external
Length of cable:	10 m
Cable type:	SEOOW 600V
Type of cable plug:	No plug
Controls:	
Control box:	not included
Additional I/O:	External
Moisture sensor:	with moisture sensors
AUTOADAPT:	NO

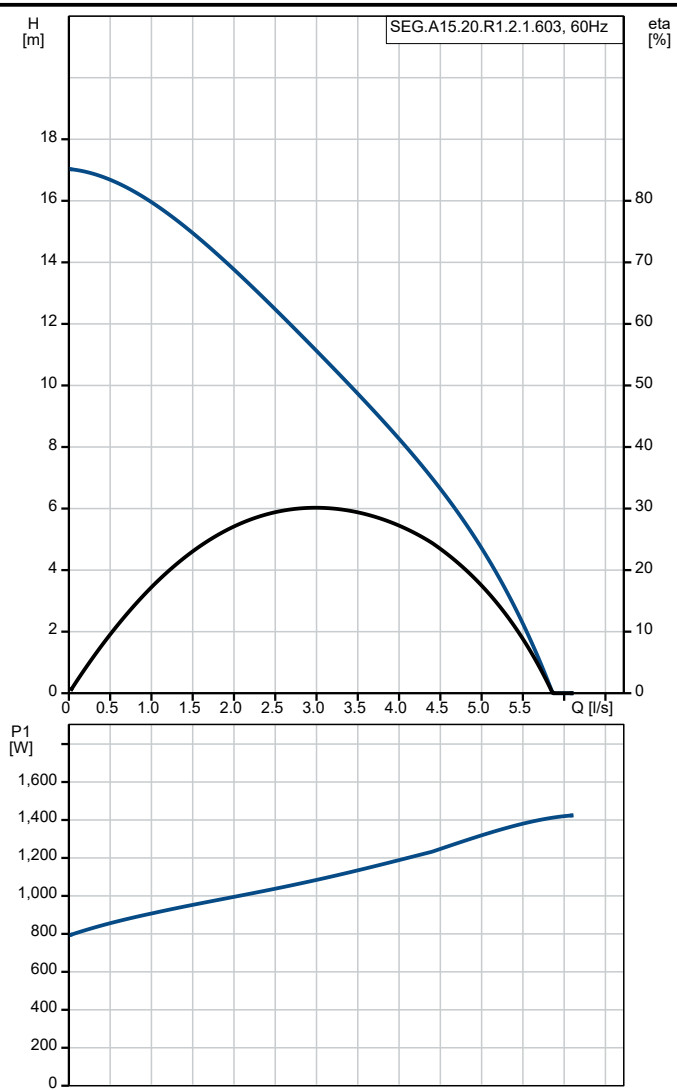

Description	Value
-------------	-------

Others:

Net weight:	48 kg
-------------	-------

Sales region:	Namreg
---------------	--------

98682359 SEG.A15.20.R1.2.1.603 60 Hz

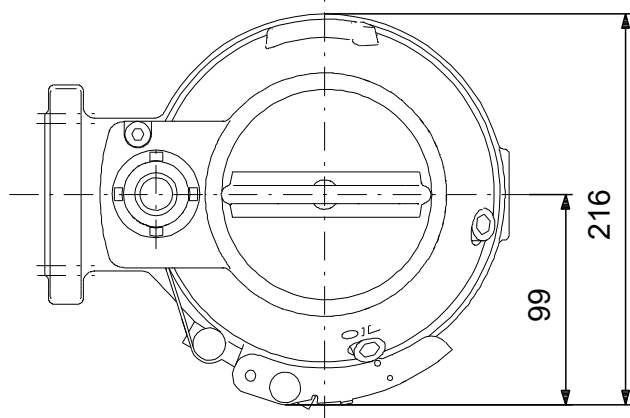
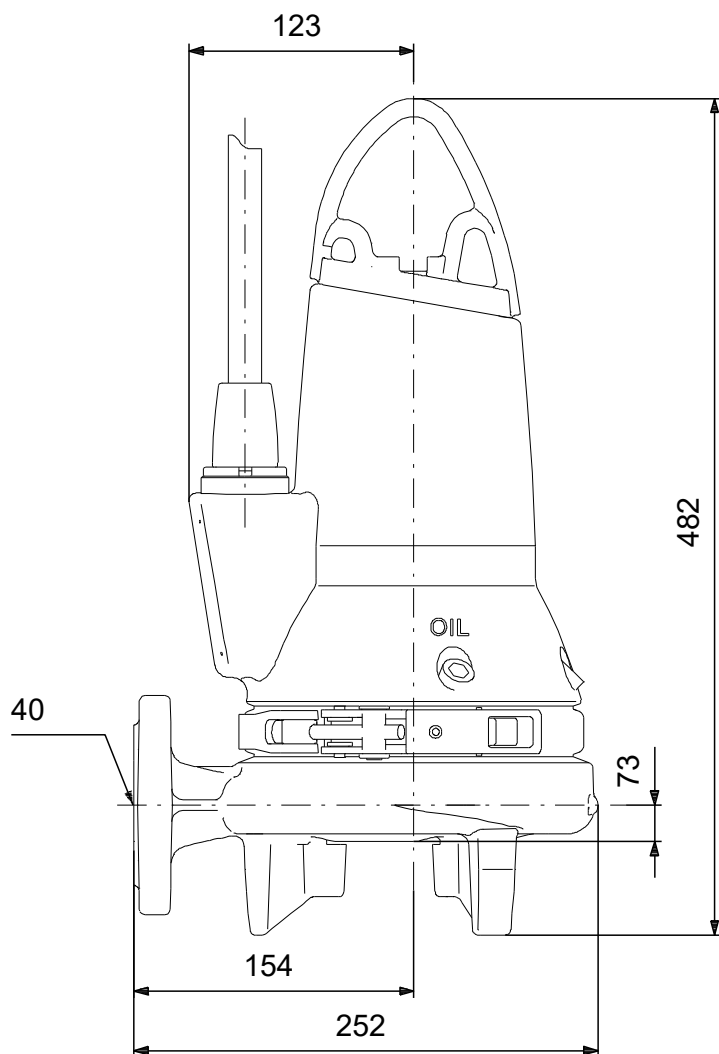

Note! All units are in [mm] unless others are stated.
Disclaimer: This simplified dimensional drawing does not show all details.

98682359 SEG.A15.20.R1.2.1.603 60 Hz

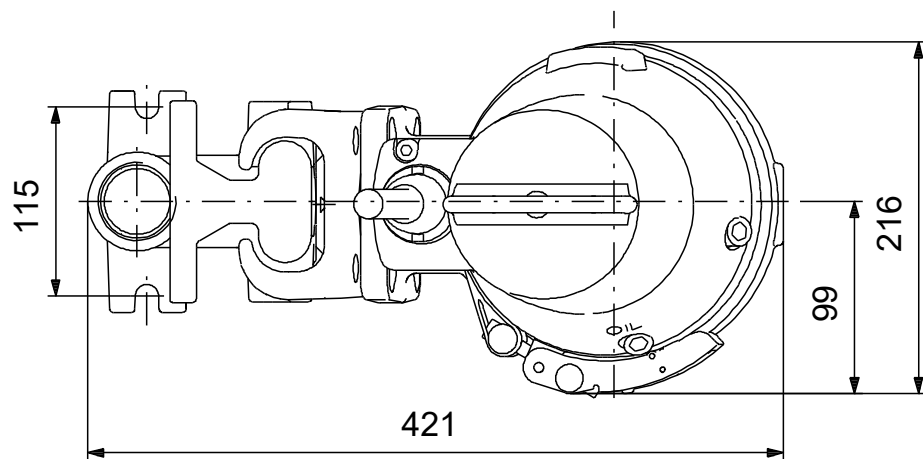
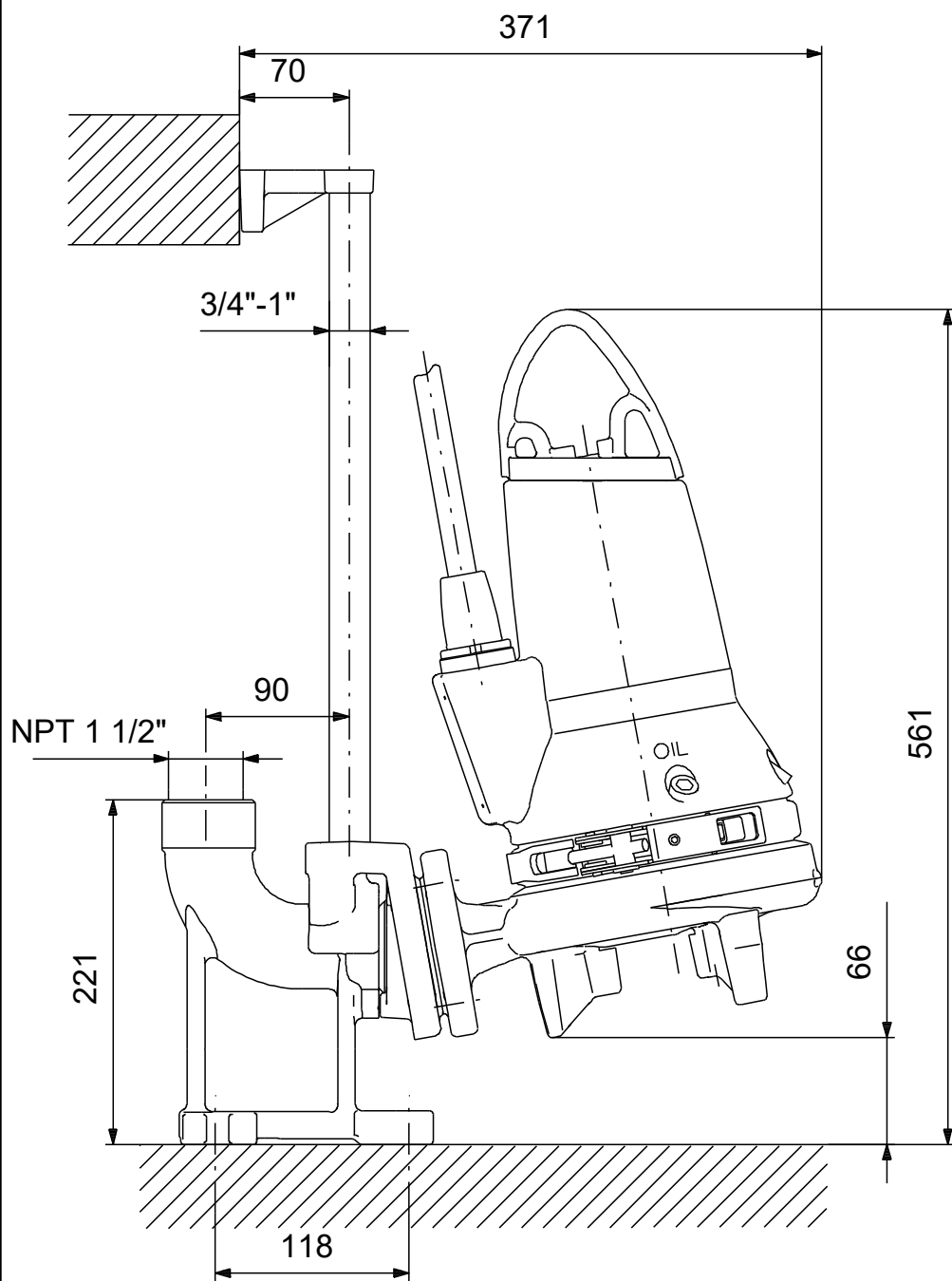

Note! All units are in [mm] unless others are stated.
Disclaimer: This simplified dimensional drawing does not show all details.

98682359 SEG.A15.20.R1.2.1.603 60 Hz

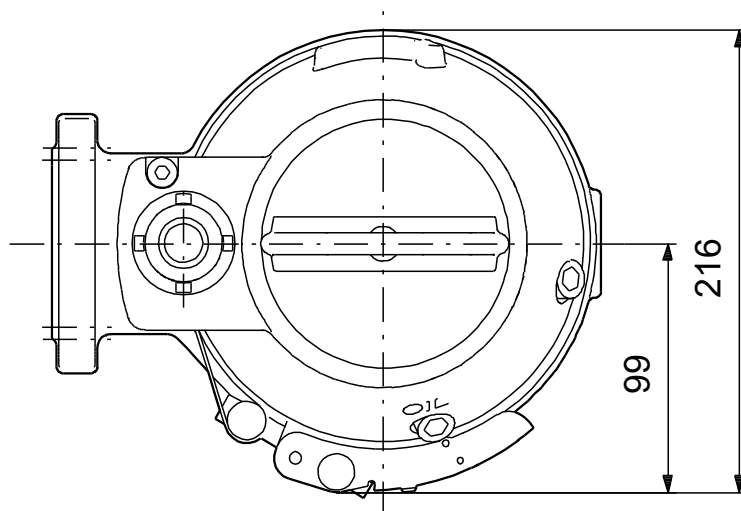
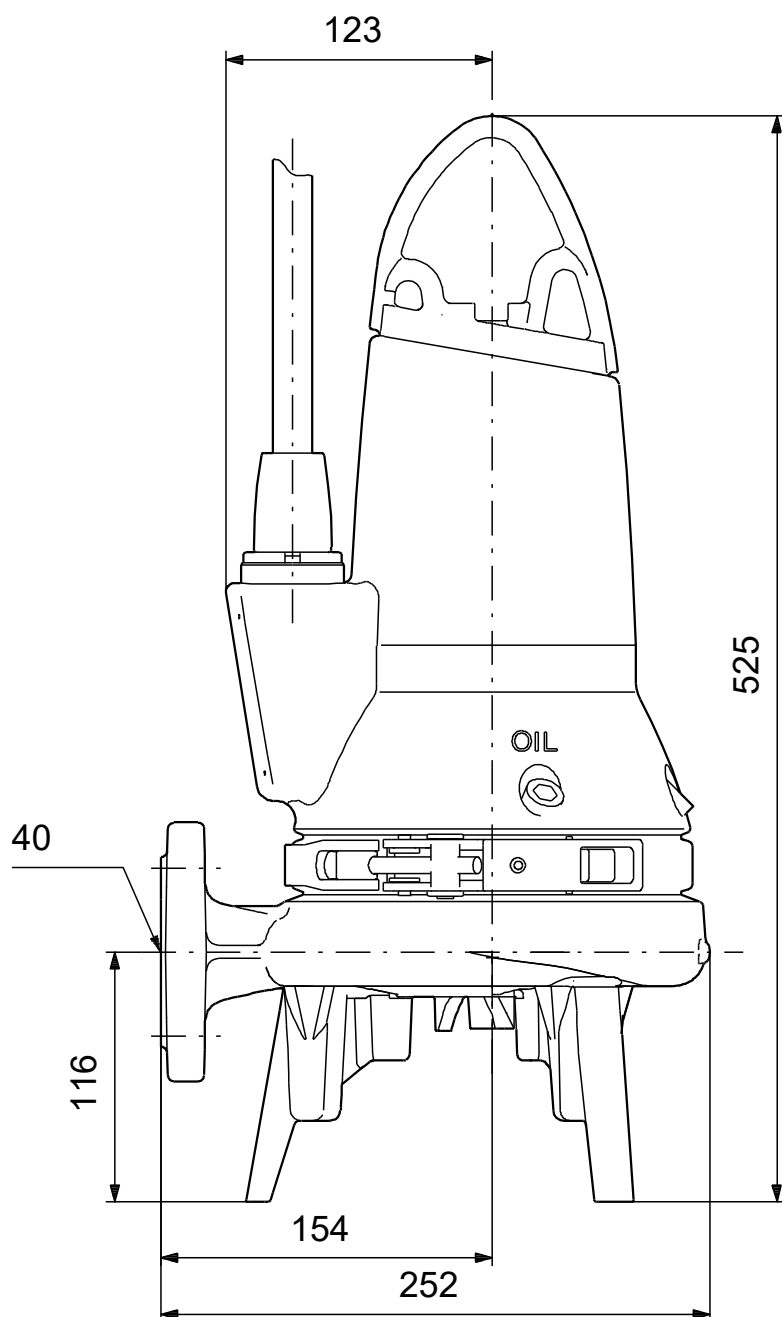

Note! All units are in [mm] unless others are stated.
Disclaimer: This simplified dimensional drawing does not show all details.

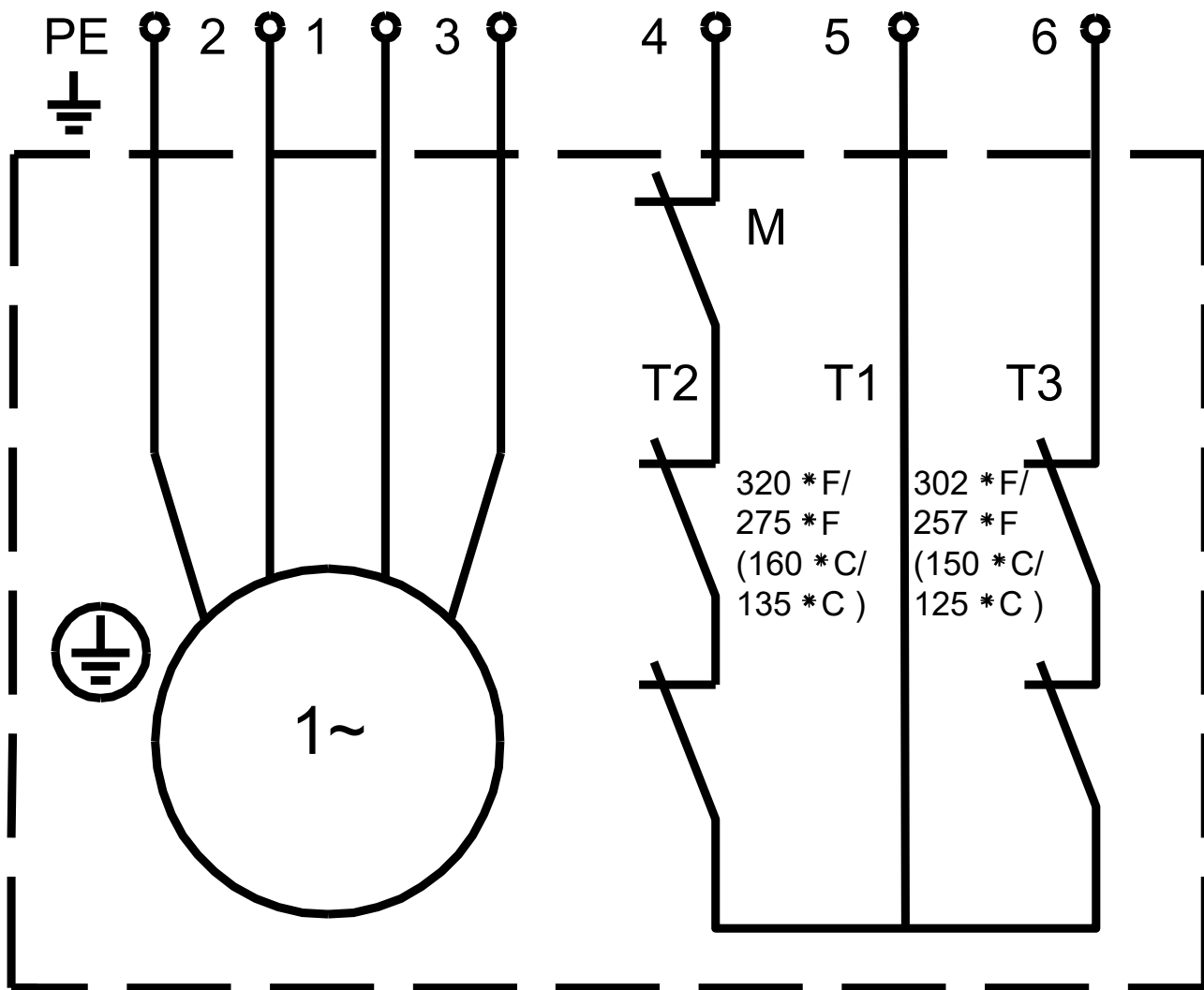
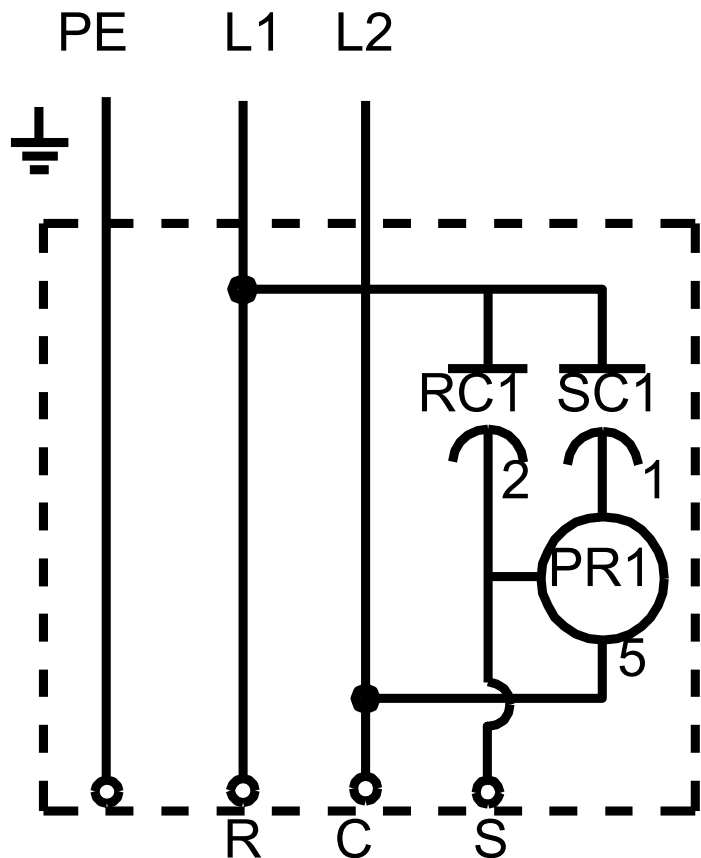

Note! All units are in [mm] unless others are stated.