

PROJECT: _____	UNIT TAG: _____	QUANTITY: _____
REPRESENTATIVE: _____	TYPE OF SERVICE: _____	DATE: _____
ENGINEER: _____	SUBMITTED BY: _____	DATE: _____
CONTRACTOR: _____	APPROVED BY: _____	DATE: _____
	ORDER NO.: _____	DATE: _____



SEG.A15.20.R2.2.60M

Submersible Grundfos SEG sewage grinder pumps (0.9-4 kW) are designed for pumping wastewater, sludge-containing water, and sewage. Fitted with a patented grinder system designed to grind the media.

Note! Product picture may differ from actual product

Conditions of Service		Pump Data		Motor Data	
Efficiency:	%	Maximum operating pressure:	87.02 psi	Rated voltage:	200-230 V
Liquid:	Any Newtonian liquid	Liquid temperature range:	32 .. 104 °F	Mains frequency:	60 Hz
NPSH required:	ft	Maximum ambient temperature:	104 °F	Number of poles:	2
Specific Gravity:	1.000	Approvals:	PA-I	Enclosure class:	IP68
		Flange standard:	ANSI	Insulation class:	F
		Product number:	98682355	Motor protection:	THERMAL SWITCH
				Thermal protection:	external

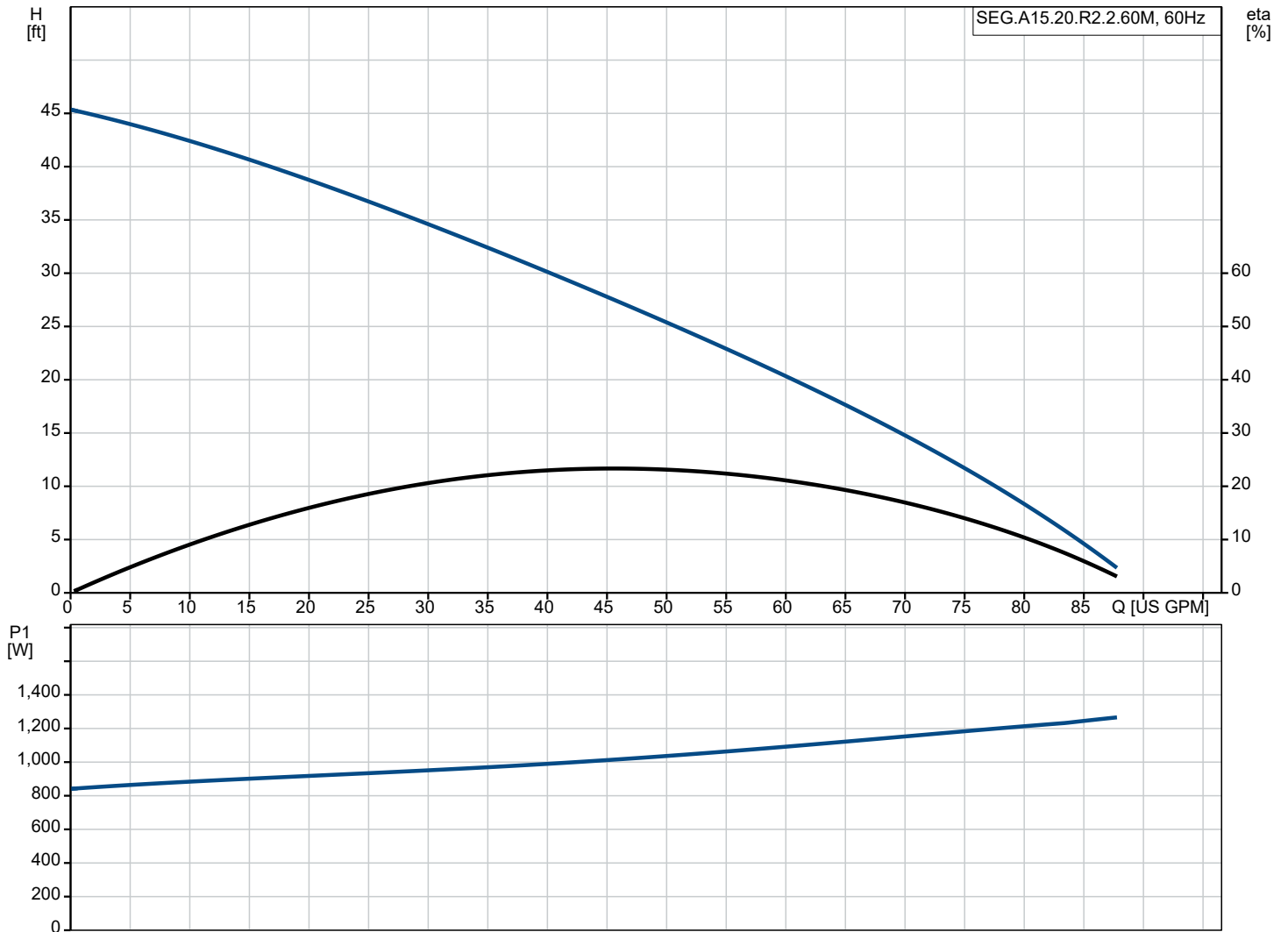

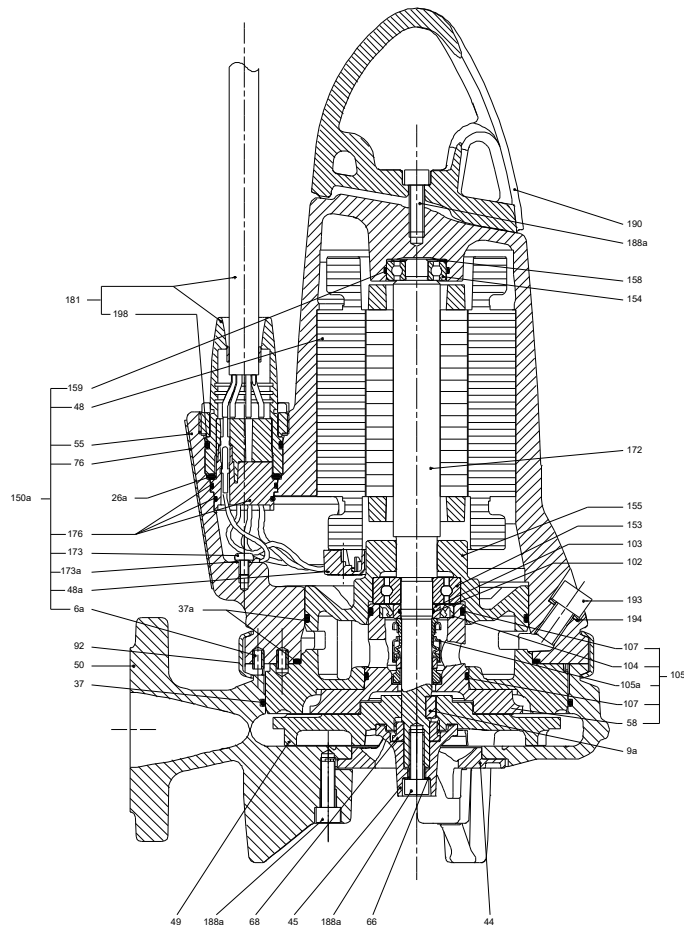
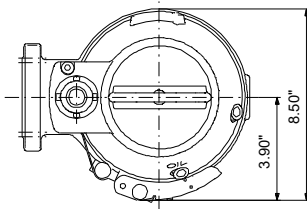
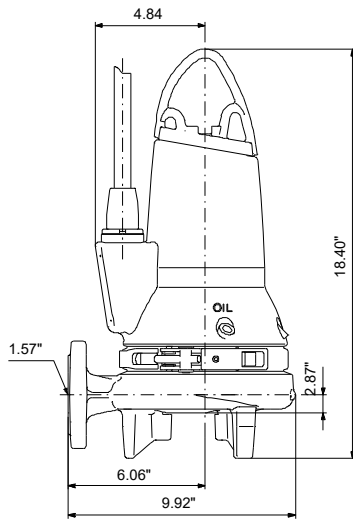

Materials:

- Pump housing: Cast iron
- Pump housing: EN1561 EN-GJL-200
- Pump housing: ASTM ASTM A48 30B
- Impeller: Cast iron
- Impeller: EN1561 EN-GJL-200
- Impeller: ASTM ASTM A48 30B

Description	Value
General information:	
Product name:	SEG.A15.20.R2.2.60M
Product No:	98682355
EAN number:	5711499540315
Technical:	
Max flow:	88.1 US GPM
Max flow:	88.1 US GPM
Head max:	45.28 ft
Type of impeller:	Grinder system
Primary shaft seal:	SIC/SIC
Approvals on nameplate:	PA-I
Curve tolerance:	ANSI/HI11.6:2017 3B2
Materials:	
Pump housing:	Cast iron
Pump housing:	EN1561 EN-GJL-200
Pump housing:	ASTM ASTM A48 30B
Impeller:	Cast iron
Impeller:	EN1561 EN-GJL-200
Impeller:	ASTM ASTM A48 30B
Installation:	
t max amb:	104 °F
Maximum operating pressure:	87.02 psi
Flange standard:	ANSI
Pipework connection:	1 1/2" /2"
Size of outlet connection:	1 1/2 inch
Pressure rating:	PN 10
Maximum installation depth:	32.8 ft
Inst dry/wet:	SUBMERGED
Auto-coupling:	98245788
Liquid:	
Pumped liquid:	Any Newtonian liquid
Liquid temperature range:	32 .. 104 °F
Density:	62.29 lb/ft³
Electrical data:	
Power input - P1:	1.2 kW
Rated power - P2:	1.21 HP
Mains frequency:	60 Hz
Rated voltage:	3 x 200-230 V
Voltage tolerance:	+6/-10 %
Max starts per. hour:	30
Rated current:	6-6 A
Starting current:	40 A
Rated current at no load:	4.1 A
Cos phi - power factor:	0.61
Cos phi - p.f. at 3/4 load:	0.52
Cos phi - p.f. at 1/2 load:	0.42
Rated speed:	3497 rpm
Moment of inertia:	0.047 lb ft²
Motor efficiency at full load:	73 %
Motor efficiency at 3/4 load:	67 %
Motor efficiency at 1/2 load:	61 %
Number of poles:	2
Start. method:	direct-on-line
Enclosure class (IEC 34-5):	IP68
Insulation class (IEC 85):	F
Explosion proof:	no
Ex-description:	WITHOUT (STANDARD)
Built-in motor protection:	THERMAL SWITCH
Thermal protec:	external
Length of cable:	33 ft
Cable type:	SEOOW 600V
Type of cable plug:	No plug
Controls:	
Control box:	not included
Additional I/O:	External
Moisture sensor:	with moisture sensors
AUTOADAPT:	NO
Others:	
Net weight:	101 lb

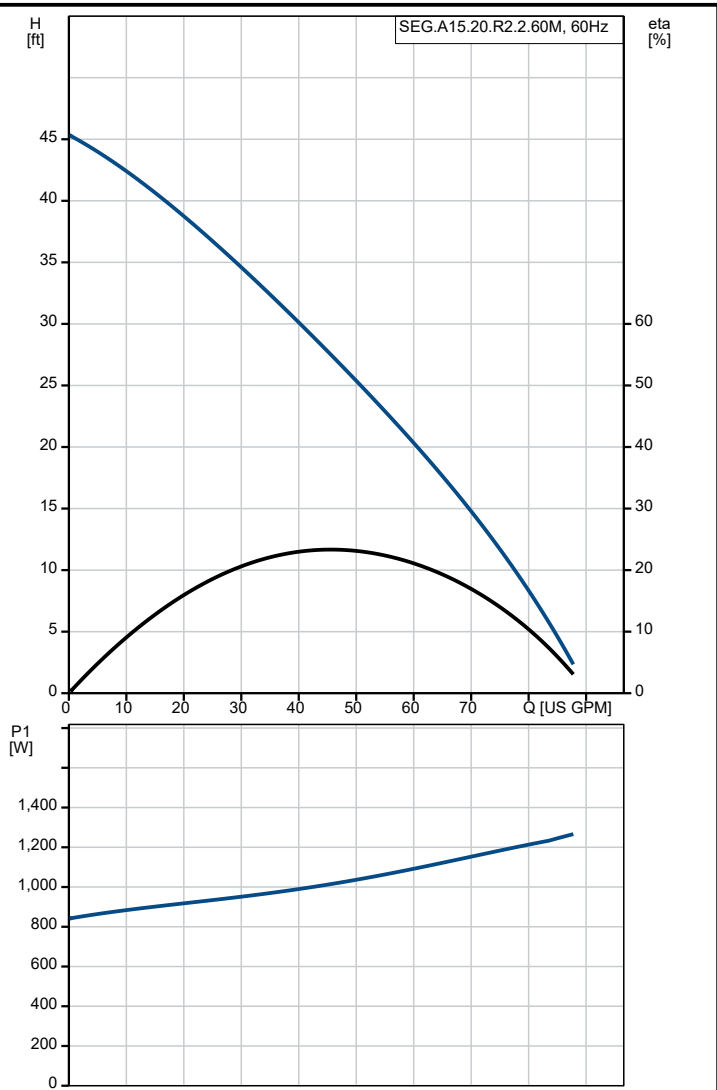

Description	Value
-------------	-------

Sales region:	Namreg
---------------	--------

98682355 SEG.A15.20.R2.2.60M 60 Hz

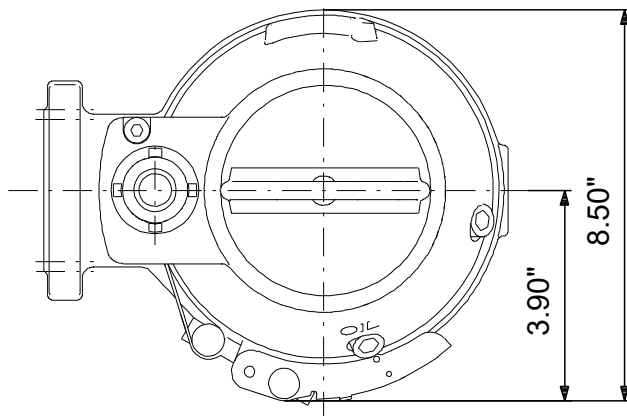
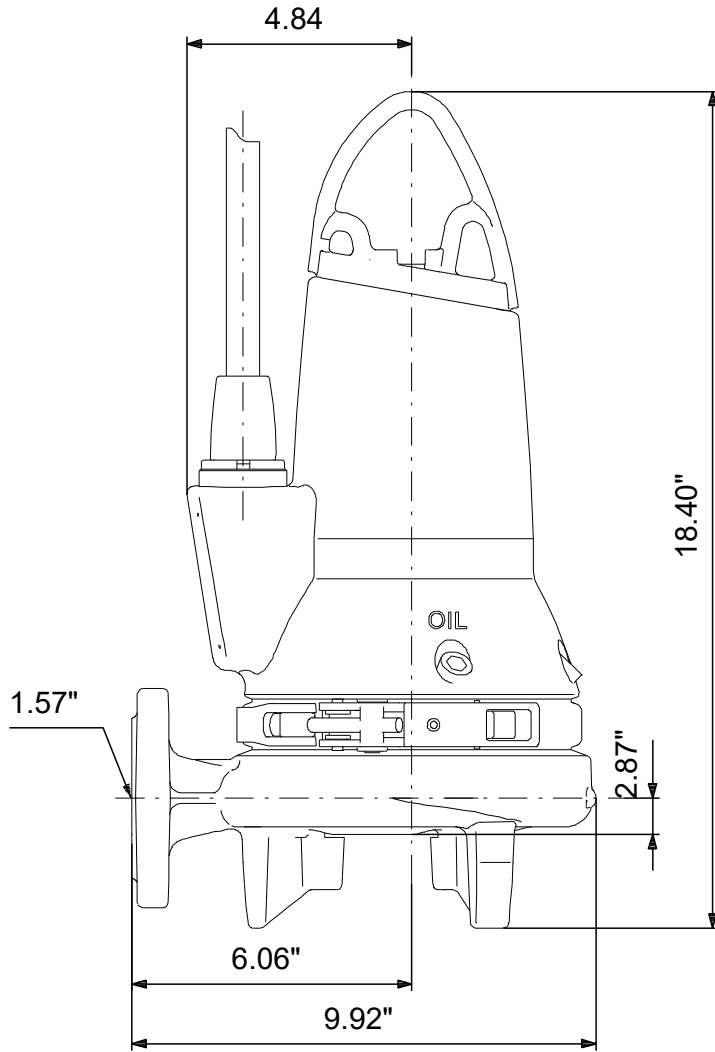

Note! All units are in [in] unless others are stated.
Disclaimer: This simplified dimensional drawing does not show all details.

98682355 SEG.A15.20.R2.2.60M 60 Hz

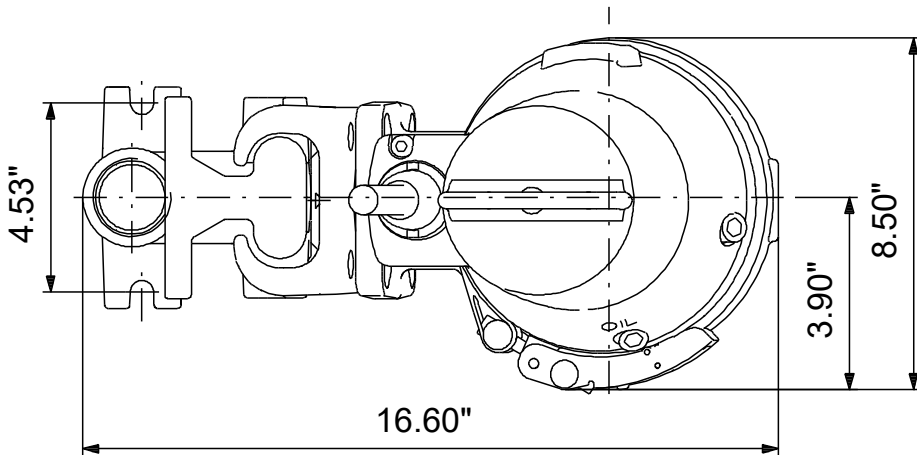
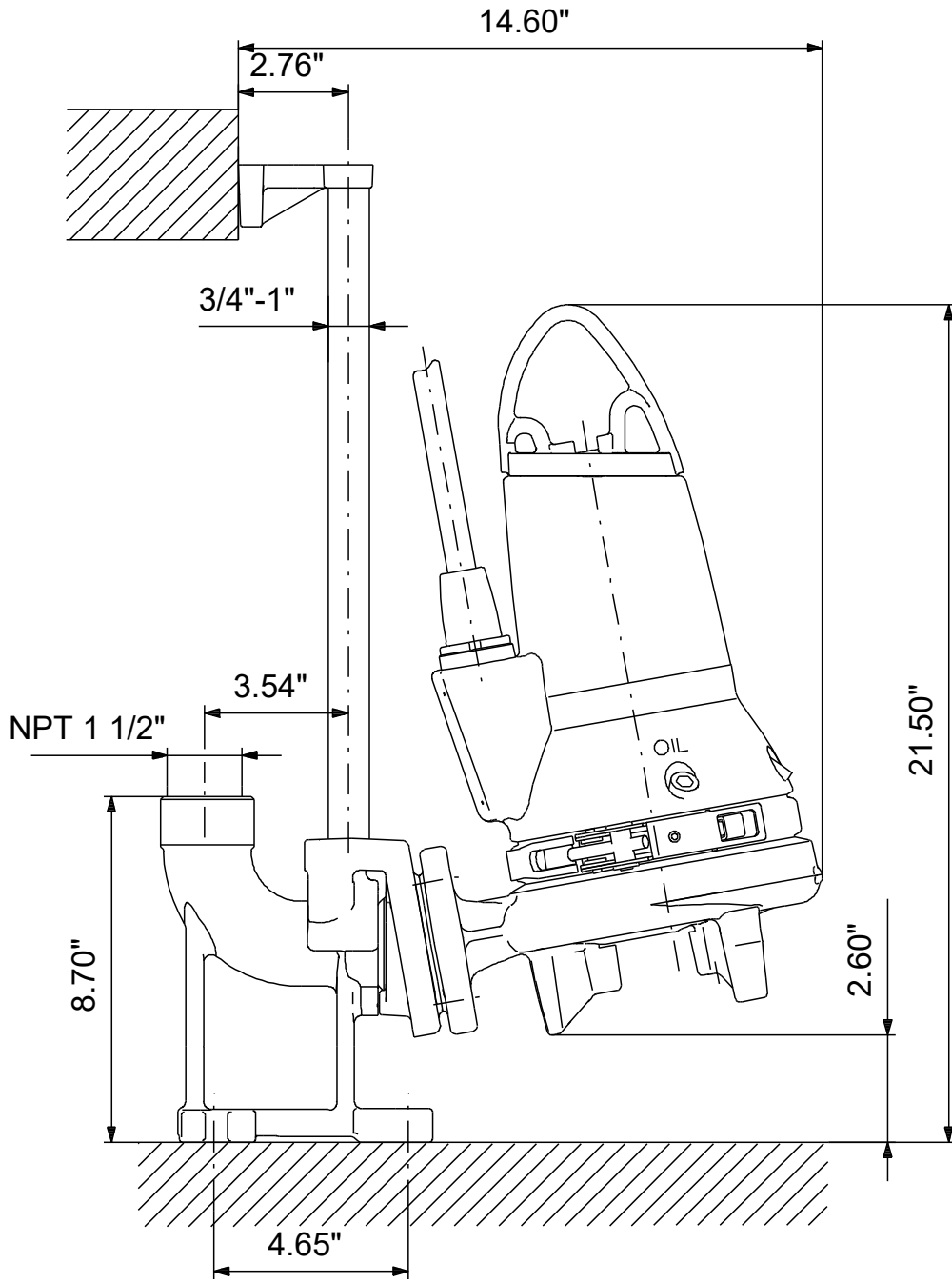

Note! All units are in [in] unless others are stated.
Disclaimer: This simplified dimensional drawing does not show all details.

98682355 SEG.A15.20.R2.2.60M 60 Hz

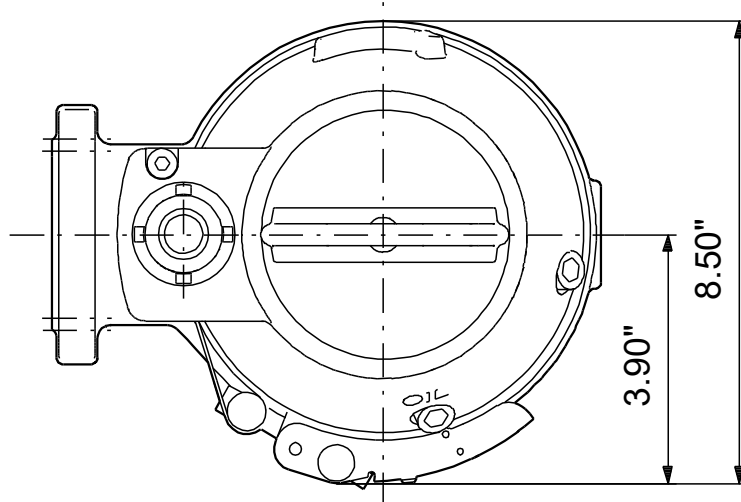
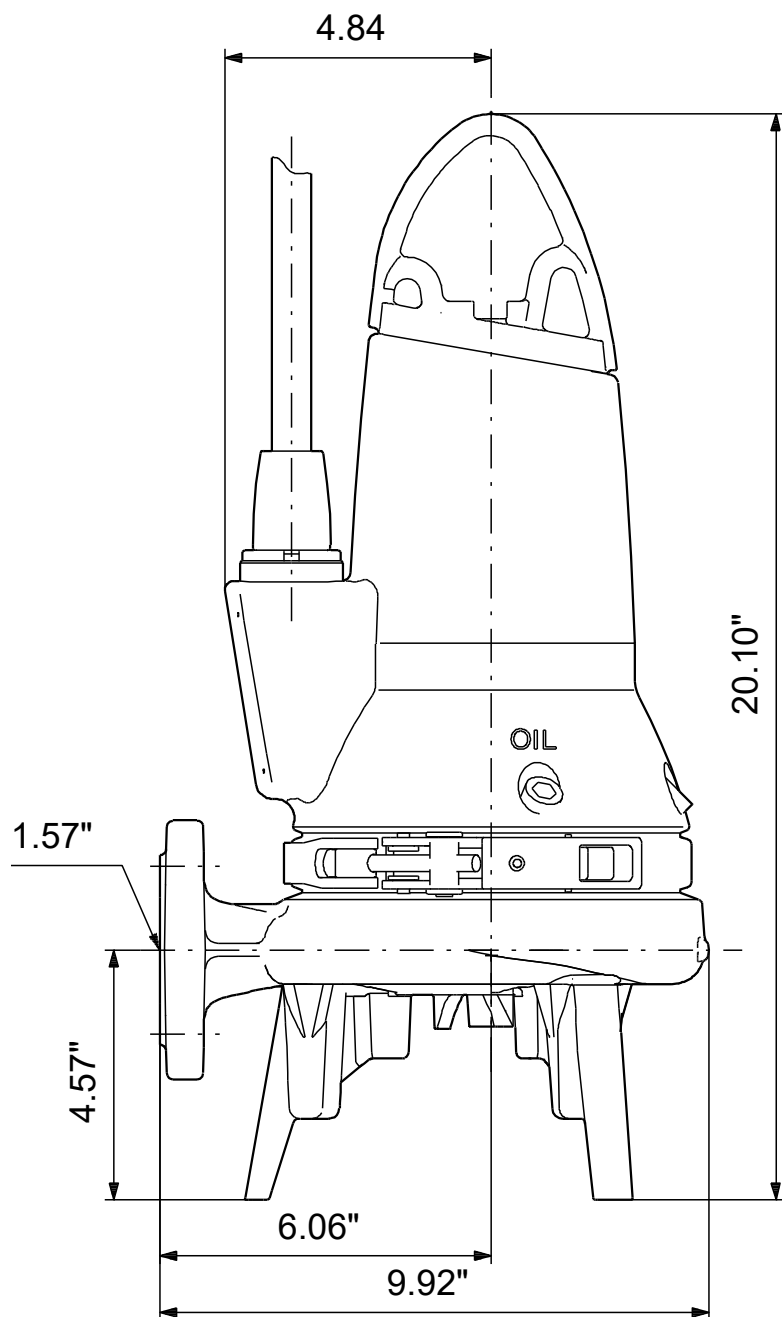

Note! All units are in [in] unless others are stated.
Disclaimer: This simplified dimensional drawing does not show all details.

PE L1 L2 L3

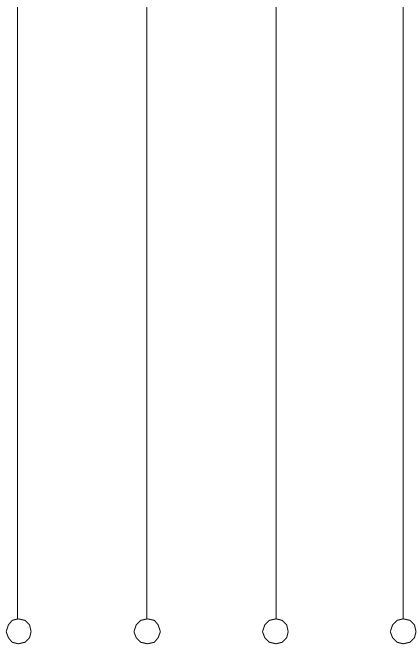

PE

1

2

3

4

5

6

7

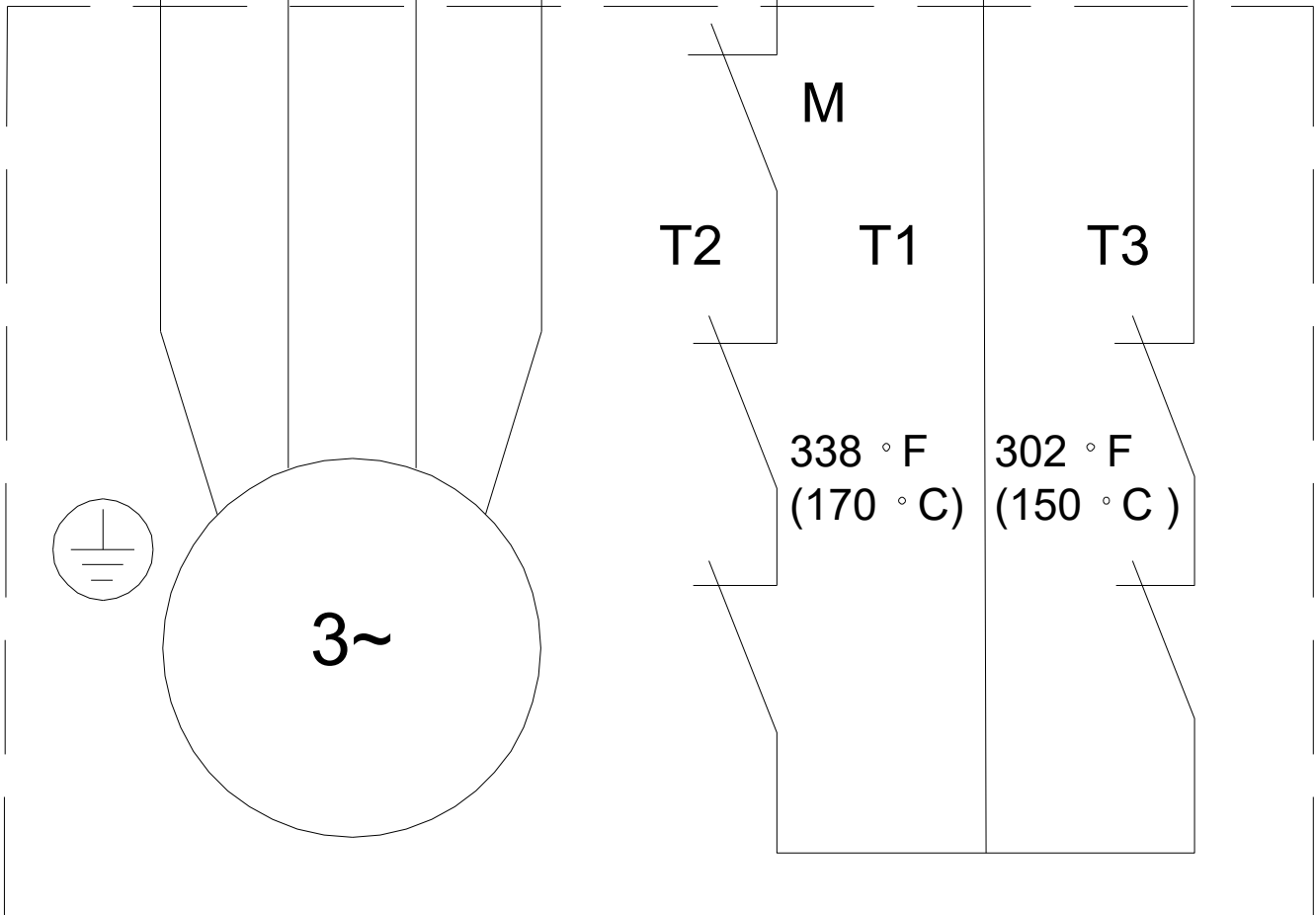

Note! All units are in [in] unless others are stated.