

Pump Performance Datasheet

Customer :	Quote Number / ID :	74718
Customer ref. / PO :	Model :	Hydro MPC-E 3CRE 3-15 3x460V
Tag Number : 001		60Hz
Service :	Part Number :	99863887
Quantity : 1	Stages :	15
Quantity of pumps : 3 active + 0 standby	Based on curve number :	RC10450
	Date last saved :	07/12/2022 9:37 PM

Operating Conditions		Liquid	
System flowrate	: 49.57 USgpm	Liquid type	: Cold Water
Flowrate per pump	: 16.52 USgpm	Additional liquid description	:
Differential head / pressure, rated (requested)	: 334.6 ft	Temperature, max	: 68.00 deg F
Differential head / pressure, rated (actual)	: 334.6 ft	Fluid density, rated / max	: 1.000 / 1.000 SG
Suction pressure, min / max	: 0.00 / 0.00 psi.g	Viscosity, rated	: 1.00 cP
NPSH available, rated	: Ample	Vapor pressure, rated	: 0.34 psi.a
Site Supply Frequency	: 60 Hz		
Power Supply	: 3ph 460V		

Performance		Material	
Speed, rated	: 3599 rpm	Material selected	: Standard - Cast Iron / 304 Stainless Steel
Speed, maximum	: 3599 rpm		
Speed, minimum	: 764 rpm		
Pump efficiency	: 55.47 %		
NPSH required / margin required	: 6.31 / 0.00 ft		
nq (imp. eye flow) / S (imp. eye flow)	: 28 / 71 Metric units		
Head maximum, rated speed	: 471.4 ft		
Head rise to shutoff	: 40.89 %		
Flow, best eff. point	: 16.51 USgpm		
Flow ratio, rated / BEP	: 100.06 %		
Speed ratio (rated / max)	: 100.00 %		
Head ratio (rated speed / max speed)	: 100.00 %		
Cq/Ch/Ce/Cn [ANSI/HI 9.6.7-2010]	: 1.00 / 1.00 / 0.97 / 1.00		
Selection status	: Acceptable		

Pressure Data	
Pump shut off pressure	: 204.0 psi.g
Maximum allowable suction pressure	: 145.0 psi.g

Driver & Power Data (@Max density) (Per Pump)	
Motor sizing specification	: Max power (non-overloading)
Margin over specification	: 0.00 %
Service factor	: 1.15
Rated power (based on duty point)	: 2.52 hp
Max power (non-overloading)	: 2.54 hp
Motor rating	: 3.00 hp / 2.24 kW (Fixed)
Panel Max FLA	: 13.4 A
MCA	: 15.6 A
MOCP	: 20 A
*Addition of pilot pump, up-sizing HP, or 575V will affect System FLA, MCA, and MOCP.	

Energy Indexes	
PEI (VL)	: Out of scope
ER (VL)	: Out of scope

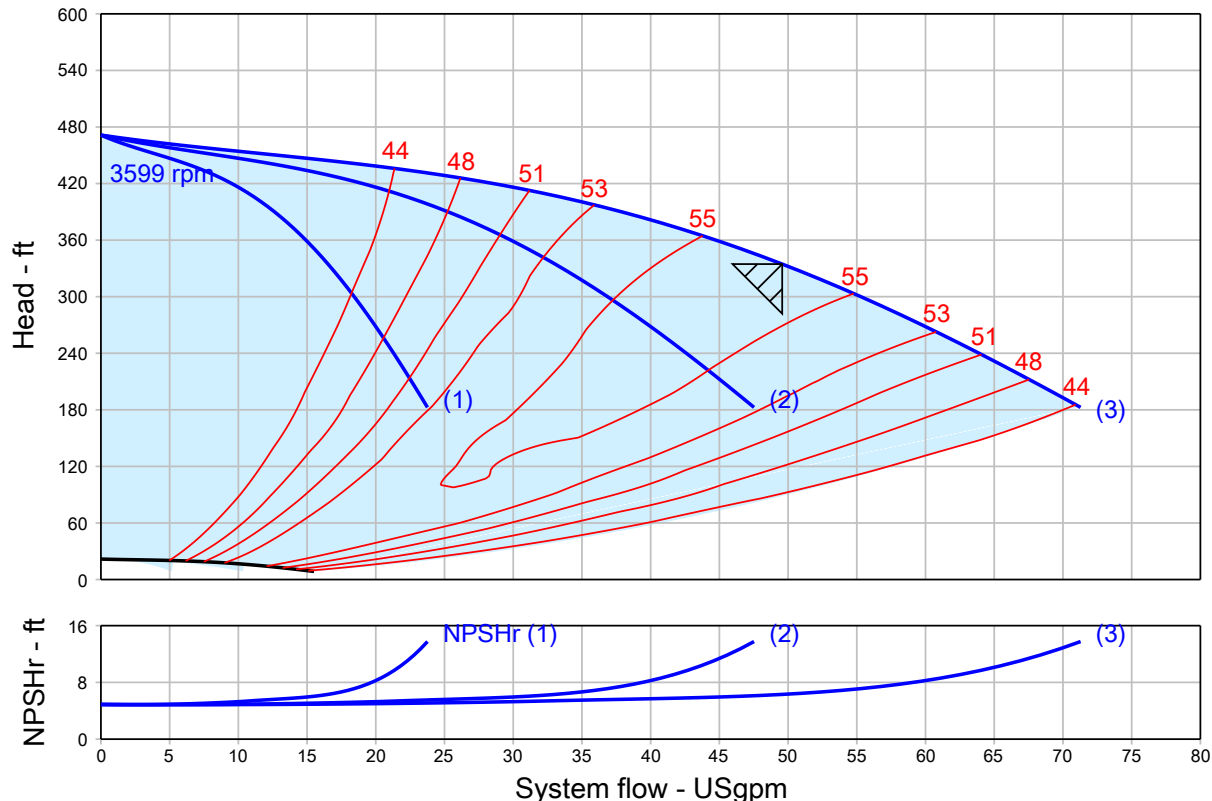

1. Manifolds 2" NPT AISI 316SS Schedule 10s ASTM A312 or \varnothing 60.3mm x2mm
 2. Base/Frame AISI 304SS
 3. Standard system layout : panel right facing suction
 4. Full port ball valve ASTM
 5. UL Type 3R/12 rated electrical panel
- Note: panel size will vary with options

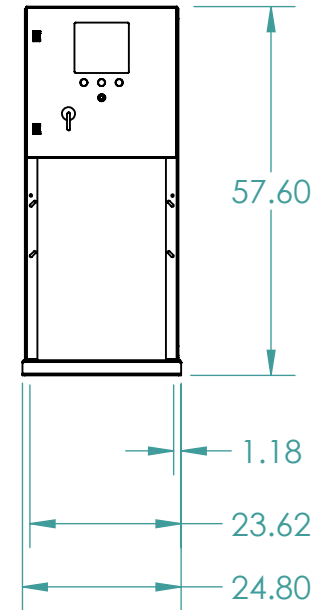
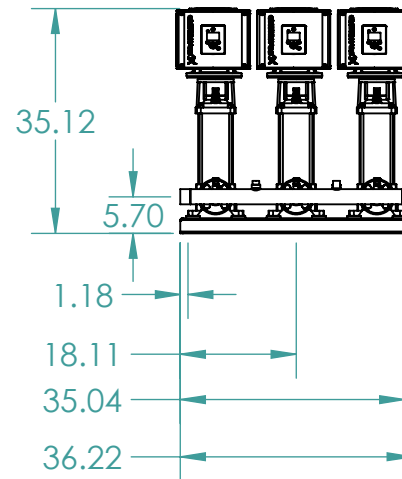
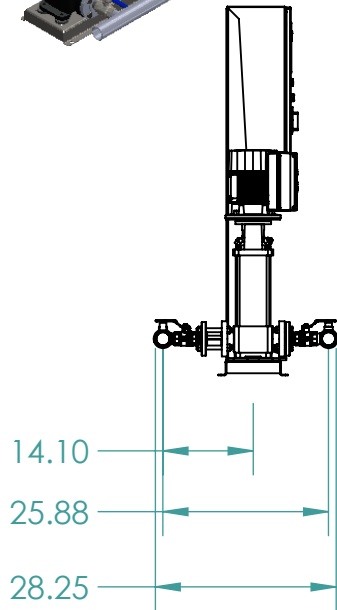
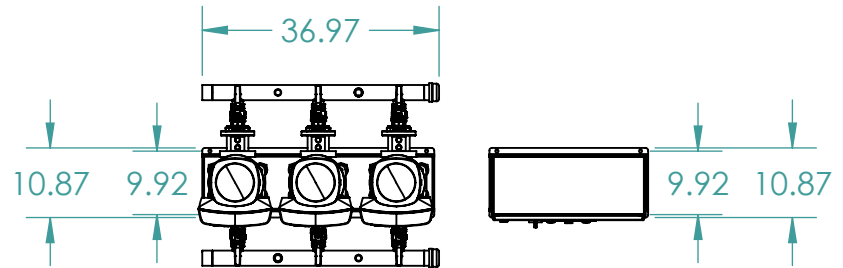
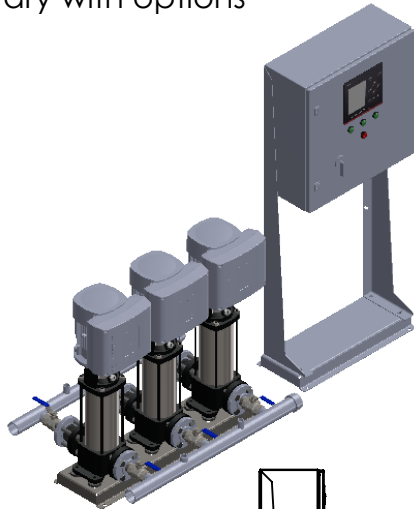

Ball Valves



General

- Threaded Ends
- Blow Out Proof Stem
- 600 WOG
- 2-Piece Body
- Teflon Seats
- Teflon Packing

Dimensions & Weights

Size	DN (in)	S (in)	H (in)	L (in)	WT. (lb)
1/4"	0.39	1.76	1.75	3.54	0.35
3/4"	0.75	2.50	2.18	3.94	0.79
1-1/4"	1.26	3.42	2.87	4.80	1.75
1-1/2"	1.57	3.76	3.48	5.91	2.47
2"	1.97	4.25	3.82	5.91	3.46

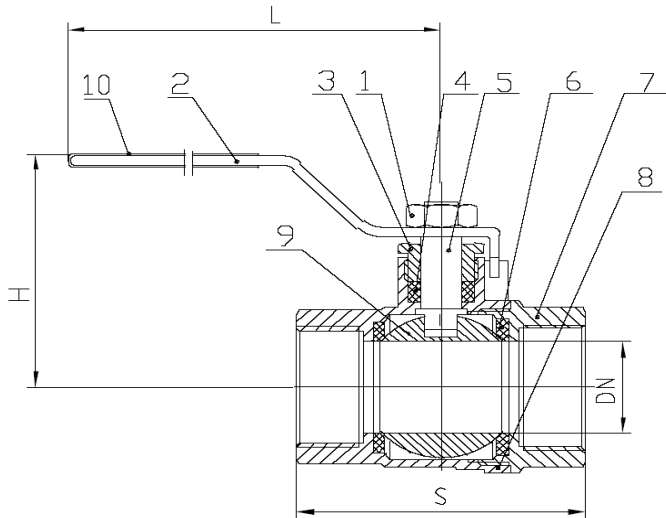

MATERIAL SPECIFICATIONS

NO. PART	MATERIAL (ASTM)
1 NUT	ZINC PLATED STEEL
2 HANDLE	ZINC PLATED STEEL
3 BONNET	BRASS (C37000)
4 PACKING	TEFLON
5 STEM	BRASS (C37000)
6 BALL SEAT	TEFLON
7 END PIECE	LOW LEAD BRASS (LTN60-6)
8 BODY	LOW LEAD BRASS (LTN60-6)
9 BALL	LOW LEAD BRASS (LTN60-6)
10 SLEEVE	PVC

APPROVALS

- NSF 61, IAPMO - N4359
- AB1953, IAPMO - 5653

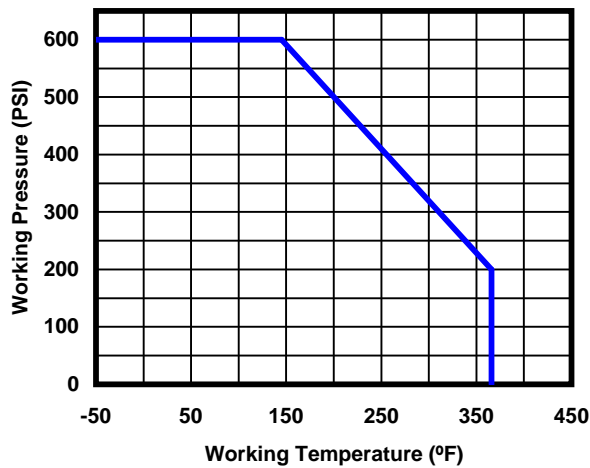

GNVP 32

Check Valve

GNVP Valves are designed exclusively for Grundfos CR pumps with threaded (oval) flanges.



Applications

GNVP valves are used in Grundfos Booster systems in domestic water systems, municipal water systems, irrigation and industrial applications where a one-way water flow is required.

Maximum Operating Pressure: 232 psi (16 bar)

Liquid Temperature: 32°F to 140°F (0°C to 60°C)

Construction

The valve body and poppet are made of high strength, corrosion resistant polyacetal. When fitted between two flanges, the EPDM o-rings provide the necessary seal for leak free operation.

Materials

Component	Materials
Valve Body	Polyacetal (POM)
Valve Cone	Polyacetal (POM)
Spring	Stainless Steel
O-rings	EPDM

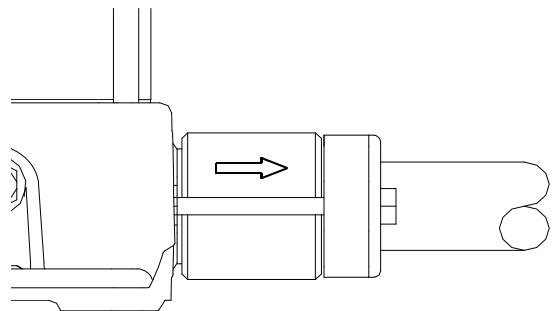
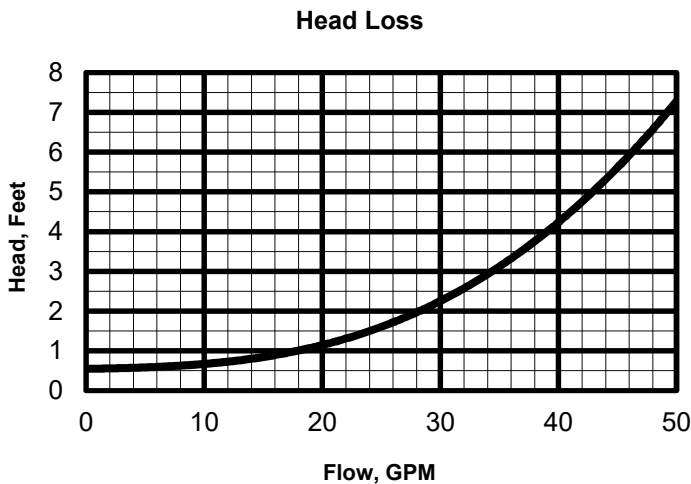

The GNVP valve is fitted between the base and flange of Grundfos CR 1s/1/3/5 pumps by means of bolts and nuts. An arrow on the valve body indicates direction of flow.

Dimensions and weights

Type	A		B		Weight	
	mm	in	mm	in	kg	lb
GNVP 32, 1 1/4"	70	2.76	60	2.36	0.24	0.53

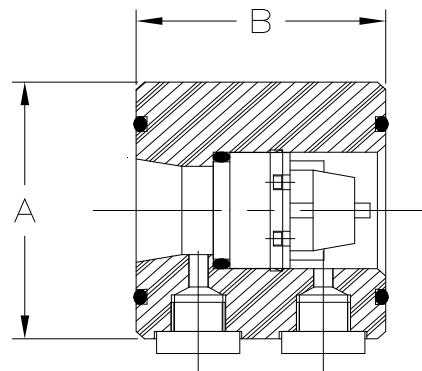

Part Number: 91040183

D80 Series

Dry or Liquid Filled • Stainless Steel Case

UTILITY GAUGES



D82LFB shown



Standard

Optional

- ▶ 1 1/2", 2", 2 1/2", 4" Dial Sizes
- ▶ ±1.6% Accuracy (1% Optional)
- ▶ Stainless Steel Case
- ▶ Glycerine Fill Standard

The Trerice **D80 Series** Industrial Gauge is designed for rugged performance requirements at an economical cost. This liquid filled gauge is furnished with a stainless steel case and crimped ring. Wetted parts are either bronze tube with Lead-Free (PBF) brass socket or stainless steel.

- Optional features and case style variations available: Please consult the Options & Accessories Section for details.
- For correct use and application of all pressure gauges, please refer to: Pressure Gauge Standard ASME B40.100.

Specifications

Models		Wetted Parts
D82B	(dry)	Bronze tube, brass socket
D82LFB	(liquid filled)	Lead-Free (PBF) Meets NSF/ANSI Standards 372 and 61
D83SS	(dry)	316 Stainless steel tube & socket
D83LFSS	(liquid filled)	
Dial Sizes	1 1/2", 2", 2 1/2", 4"	
Fill	Glycerine, other fills available See Optional Features Section	
Movement	D82: Brass D83: 316 Stainless steel	
Connection	Lower male or center back male, (Lower back male 4" Dial only)	
Case	304 stainless steel, stem-mounted flangeless	
Ring	Crimped 304 stainless steel	
Window	Acrylic	
Pointer	Plain, black finished	
Dial Face	Aluminum, white background with black graduations and markings	
Accuracy	±1.6% Full Scale (1% available as an option)	
Maximum Temperature	150°F (65°C)	

Approximate Shipping Weight

- 1 1/2" Dial Size: 0.4 lbs [0.18 kg]
- 2" Dial Size: 0.4 lbs [0.18 kg]
- 2 1/2" Dial Size: 0.5 lbs [0.23 kg]
- 4" Dial Size: 1.0 lbs [0.45 kg]

HOW TO ORDER

Sample Order Number: **D82LFB 25 02 L A 110**

Model	Dial Size	Connection Size	Connection Location	Units of Measure	Range Code
D82LFB	15 1 1/2"	01 1/8 NPT*	L Lower	A psi	See Standard Ranges
D83LFSS	20 2"	02 1/4 NPT**	B Back	D psi/kPa	
D82B	25 2 1/2"	04 1/2 NPT***			
D83SS	40 4"				

* 1/8 NPT connection size not available with 4" dial size.
 ** 1/4 NPT connection size not available with 1 1/2" dial size.
 *** 1/2 NPT connection size only available with 4" dial size.

D80 Series

Dry or Liquid Filled • Stainless Steel Case

All dimensions are nominal. Dimensions in [] are in millimeters.

UTILITY GAUGES

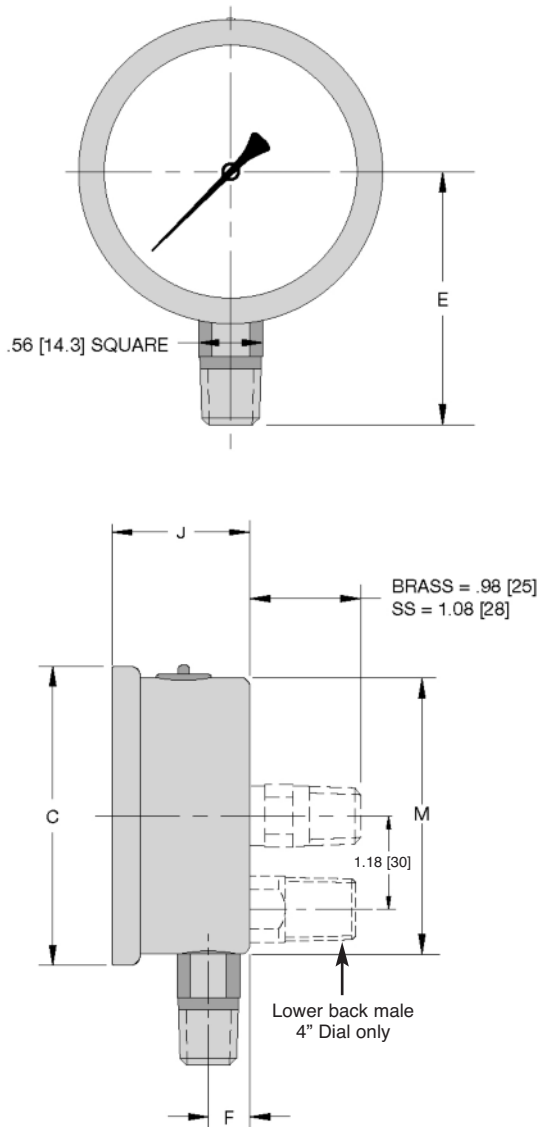

Standard Ranges

psi Ranges (A)		D82		D83	
Range Code	Specific Range (psi)	Figure Intervals	Minor Divisions	Figure Intervals	Minor Divisions
010	30" Hg to 0	5	0.5	5	0.5
020	30" Hg to 15 psi	10/5	1/0.5	10/5	1/0.5
030	30" Hg to 30 psi	10/5	1/1	10/5	1/1
040	30" Hg to 60 psi	10/10	2/1	10/10	2/1
050	30" Hg to 100 psi	30/20	2/2	30/20	2/2
060	30" Hg to 150 psi	30/30	5/2	30/30	5/2
070	30" Hg to 300 psi	30/50	5/5	30/50	5/5
080	0 to 15 psi	3	0.2	3	0.2
090	0 to 30 psi	5	0.5	5	0.5
100	0 to 60 psi	10	1	10	1
110	0 to 100 psi	10	1	10	1
120	0 to 160 psi	20	2	20	2
130	0 to 200 psi	20	2	20	2
140	0 to 300 psi	50	5	50	5
150	0 to 400 psi	50	5	50	5
160	0 to 600 psi	100	10	100	10
180	0 to 1000 psi	100	20	100	20
190	0 to 1500 psi	300	20	300	20
200	0 to 2000 psi	200	20	200	20
210	0 to 3000 psi	500	50	500	50
220	0 to 5000 psi	1000	100	1000	100

Ranges over 5000 PSI are not available on D82LFB.

230	0 to 10000 psi	N/A	N/A	2000	200
240	0 to 15000 psi	N/A	N/A	3000	200

For dual scale ranges specify the appropriate **Units of Measure: D** (psi/kPa) followed by the corresponding **A** (psi) **Range Code**

Dial Size	C	E	F	J	M
1 1/2" D82	1.85 [47]	1.50 [38]	0.32 [8]	1.06 [27]	1.61 [41]
1 1/2" D83	1.85 [47]	1.50 [38]	0.32 [8]	1.06 [27]	1.61 [41]
2" D82	2.28 [58]	1.89 [48]	0.39 [10]	1.14 [29]	2.05 [52]
2" D83	2.28 [58]	2.05 [52]	0.35 [9]	1.18 [30]	2.05 [52]
2 1/2" D82	2.68 [68]	2.24 [57]	0.39 [10]	1.18 [30]	2.44 [62]
2 1/2" D83	2.68 [68]	2.32 [59]	0.51 [13]	1.38 [35]	2.44 [62]
4" D82	4.29 [109]	3.07 [78]	0.47 [12]	1.42 [36]	3.90 [99]
4" D83	4.29 [109]	3.94 [100]	0.75 [19]	1.93 [49]	3.94 [100]

Data sheet

MBS 3000 pressure transmitter for industrial applications

Introduction



- Designed for use in severe industrial environments
- Enclosure and wetted parts of acid-resistant stainless steel (AISI 316L)
- All standard output signals: 4-20 mA, 0-5 V, 1-5 V, 1-6 V, 0-10 V
- A wide range of pressure and electrical connections
- Temperature compensated and laser calibrated
- Typical applications:
 - Pumps
 - Compressors
 - Pneumatics
 - Water treatment

Dimensions

Ordering

Type code Page 4	8	2	5	7	1	3
	AMP Superseal 1.5 series (male)	AMP Econoseal J series (male)	IEC 947-5-2 M12x1, 4-pin	ISO 15170-A1-3.2-Sn (Bayonet plug)	DIN 43650, Pg 9	2 m screened cable

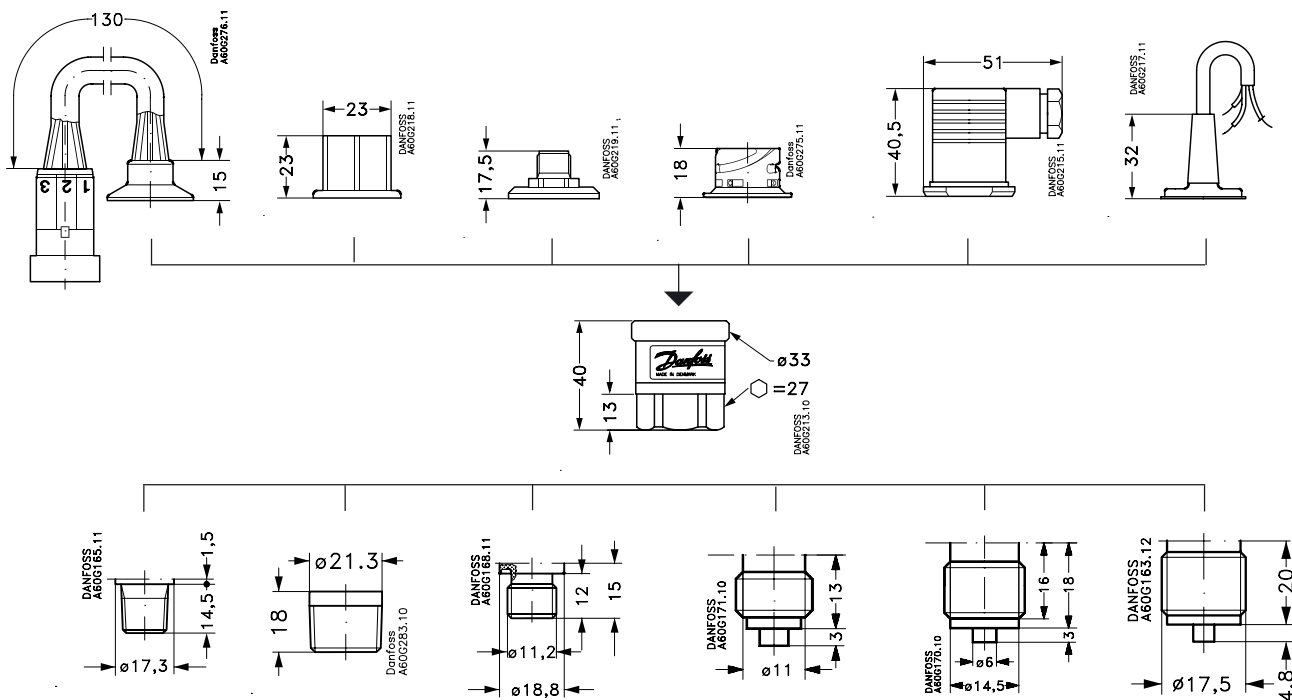

Ordering

	1/4 - 18 NPT	1/2 - 14 NPT	DIN 3852-E-G1/4 Gasket: DIN 3869-14	G 1/4 A (EN 837)	G 3/8 A (EN 837)	G 1/2 A (EN 837)
Type code page 4	AC04	AC08	GB04	AB04	AB06	AB08

Technical data
Main specifications

Pressure connections	see page 1							
Measuring ranges [bar]	0-1 0-25	0-1.6 0-40	0-2.5 0-60	0-4 0-100	0-6 0-160	0-10 0-250	0-16 0-400	0-600
Output signals	4-20 mA	0-5 V	1-5 V	1-6 V	0-10 V			
Electrical connections	see page 3							

Performance (IEC 770)

Accuracy	±0.5% FS (typ.) ±1% FS (max.)
Non-linearity (best fit straight line)	≤ ±0.5% FS
Hysteresis and repeatability	≤ ±0.1% FS
Thermal zero point shift	≤ ±0.1% FS/10K (typ.) ≤ ±0.2% FS/10K (max.)
Thermal sensitivity (span) shift	≤ ±0.1% FS/10K (typ.) ≤ ±0.2% FS/10K (max.)
Response time	< 4 ms
Overload pressure	6 × FS (max. 1500 bar)
Burst pressure	6 × FS (max. 2000 bar)
Durability, P: 10-90% FS	>10×10 ⁶ cycles

Electrical specifications

	Nom. output signal (short-circuit protected)		
	4 – 20 mA	0-5, 1-5, 1-6 V d.c.	0-10 V d.c.
Supply voltage [U _B], polarity protected	9 → 32 V d.c.	9 → 30 V d.c.	15 → 30 V d.c.
Supply - current consumption	-	≤ 5 mA	≤ 8 mA
Supply voltage dependency	≤ ±0.05% FS/10 V		
Current limitation (linear output up to 1.5x nom. range)	34 mA (typ.)	-	
Output impedance	≤ 25Ω		
Load [R _L] (load connected to 0V)	R _L ≤ (U _B -9V)/0.02	R _L ≥ 10 kΩ	R _L ≥ 15 kΩ

Environmental conditions

Medium temperature range	-40 → +85°C			
Ambient temperature range (depending on electrical connection)	see page 3			
Compensated temperature range	0 → +80°C			
Transport temperature range	-50 → +85°C			
EMC - Emission	EN 61000-6-3			
EMC - Immunity	Electrostatic discharge	Air mode	8 kV	EN 61000-6-2
		Contact mode	4 kV	EN 61000-6-2
	RF field	conducted	10 V/m, 26 MHz - 1 GHz	EN 61000-6-2
		radiated	10 V _{rms} , 150 kHz - 30 MHz	EN 61000-6-2
	Transient	burst	4 kV (CM), Clamp	EN 61000-6-2
surge		1 kV (CM,DM), Rg = 42Ω	EN 61000-6-2	
Insulation resistance	> 100 MΩ at 100 V d.c.			
Mains frequency test	500 V, 50 Hz		SEN 361503	
Vibration stability	Sinusoidal	15.9 mm-pp, 5Hz-25Hz	IEC 60068-2-6	
		20 g, 25 Hz - 2 kHz		
Shock resistance	Random	7.5 g _{rms} , 5 Hz - 1 kHz	IEC 60068-2-34, IEC 60068-2-36	
	Shock	500 g / 1 ms	IEC 60068-2-27	
Enclosure (depending on electrical connection)	Free fall		IEC 60068-2-32	
	see page 3			

Mechanical characteristics

Materials	Wetted parts	DIN 17440-1.4404 (AISI 316 L)
	Enclosure	DIN 17440-1.4404 (AISI 316 L)
	Electrical connections	see page 3
Weight (depending on pressure connection and electrical connection)	0.2-0.3 kg	

Electrical connections

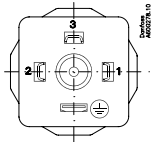
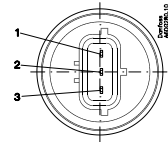
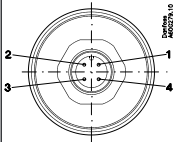
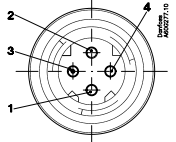
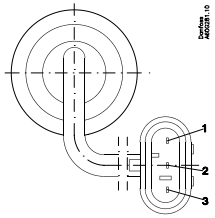
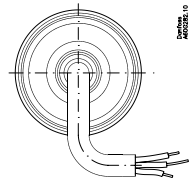
Type code, page 4					
1	2	5	7	8	3
DIN 43650, Pg 9 	AMP Econoseal J series (male) 	IEC 947-5-2 M12x1 	ISO 15170-A1-3.2-Sn (Bayonet plug) 	AMP Superseal 1.5 series (male) 	2 m screened cable 
<i>Ambient temperature</i>					
-40 → + 85 °C	-40 → + 85 °C	-25 → +85 °C	-40 → +85 °C	-40 → +85 °C	-30 → +85 °C
<i>Enclosure</i>					
IP 65	IP 67	IP 67	IP 67 / IP 69K	IP 67	IP67
<i>Materials</i>					
Glass filled polyamid, PA 6.6	Glass filled polyamid, PA 6.6 ¹⁾	Nickel plated brass, CuZn/Ni	Glass filled polyester, PBT	Glass filled polyamid, PA 6.6 ²⁾	Polyolifin cable with PE shrinkage tubing
<i>Electrical connection, 4-20 mA output (2 wire)</i>					
Pin 1: +supply Pin 2: ÷supply Pin 3: Not used Earth: Connected to MBS housing	Pin 1: +supply Pin 2: ÷supply Pin 3: Not used	Pin 1: +supply Pin 2: Not used Pin 3: Not used Pin 4: ÷supply	Pin 1: +supply Pin 2: ÷supply Pin 3: Ventilation Pin 4: Not used	Pin 1: +supply Pin 2: ÷supply Pin 3: Not used	Brown wire: +supply Black wire: ÷supply Red wire: Not used Orange: Not used Screen: Not connected to MBS housing
<i>Electrical connection, 0-5V, 1-5V, 1-6V, 0-10V output</i>					
Pin 1: +supply Pin 2: ÷supply Pin 3: Output Earth: Connected to MBS housing	Pin 1: +supply Pin 2: ÷supply Pin 3: Output	Pin 1: +supply Pin 2: not used Pin 3: Output Pin 4: ÷supply	Pin 1: +supply Pin 2: Output Pin 3: Ventilation Pin 4: ÷supply	Pin 1: +supply Pin 2: ÷supply Pin 3: Output	Brown wire: Output Black wire: ÷supply Red wire: + supply Orange: Not used Screen: Not connected to MBS housing

1) Female plug: Glass filled polyester, PBT
 2) Wire: PETFE (teflon)
 Protection sleeve: PBT mesh (polyester)

Ordering of standard MBS 3000 with DIN 43650 plug Pg 9

Pressure connection	Pressure range Pe	Type	Code no.
G 1/4 A (EN 837)	0 - 1 bar	MBS 3000 1011-1 AB04	060G1113
	0 - 1.6 bar	MBS 3000 1211-1 AB04	060G1429
	0 - 2.5 bar	MBS 3000 1411-1 AB04	060G1122
	0 - 4 bar	MBS 3000 1611-1 AB04	060G1123
	0 - 6 bar	MBS 3000 1811-1 AB04	060G1124
	0 - 10 bar	MBS 3000 2011-1 AB04	060G1125
	0 - 16 bar	MBS 3000 2211-1 AB04	060G1133
	0 - 25 bar	MBS 3000 2411-1 AB04	060G1430
	0 - 40 bar	MBS 3000 2611-1 AB04	060G1105
	0 - 60 bar	MBS 3000 2811-1 AB04	060G1106
	0 - 100 bar	MBS 3000 3011-1 AB04	060G1107
	0 - 160 bar	MBS 3000 3211-1 AB04	060G1112
	0 - 250 bar	MBS 3000 3411-1 AB04	060G1111
	0 - 400 bar	MBS 3000 3611-1 AB04	060G1109
0 - 600 bar	MBS 3000 3811-1 AB04	060G1110	

Ordering of special versions

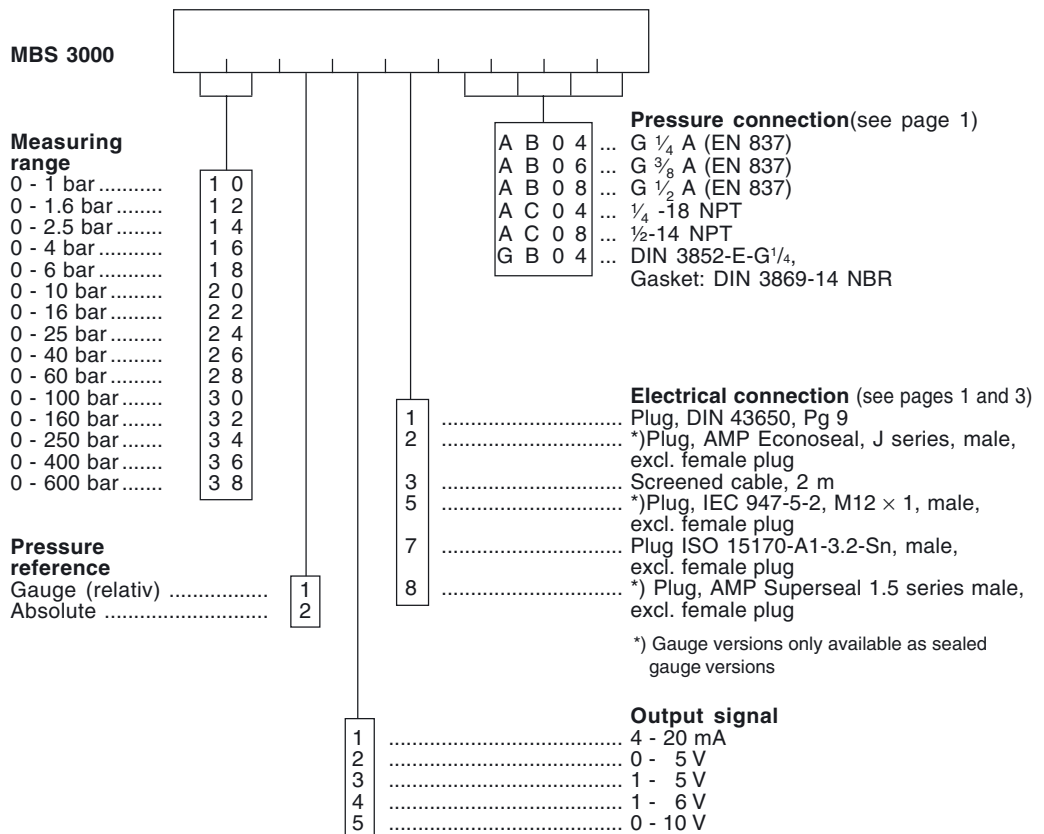

Danfoss can accept no responsibility for possible errors in catalogues, brochures and other printed material. Danfoss reserves the right to alter its products without notice. This also applies to products already on order provided that such alterations can be made without subsequential changes being necessary in specifications already agreed. All trademarks in this material are property of the respective companies. Danfoss and the Danfoss logotype are trademarks of Danfoss A/S. All rights reserved.

Grundfos CU 352 Pump Controller

Advanced pump system controller for parallel connected pumps for HVAC and Pressure Boosting Applications



Compatibility

The CU 352 pump controller can control up to six (6) parallel connected pumps in the following manner:

- Direct BUS control: **CRE, CME, VLSE or LCSE** pumps
- Direct BUS control: Pumps with Grundfos **CUE** drives
- Digital/Analog control: Pumps with external drives (requires **IO 351B** Input/Output module)

HVAC Control Modes

- o Constant Differential Pressure control via remote sensor
- Multi-zone Differential Pressure control up to 6 zones
 - Priority, Minimum or Energy Saving Mode
- o Quadratic, proportional or constant differential pressure control via local sensor
 - Adjustable control curve (Max flow and control head)
 - Efficiency based sequencing automatically updated
- o Constant Flow
- o Constant Temperature
- o Constant Differential Temperature

Pressure Boosting Control Modes

- o Constant Pressure (pump discharge)
- o Quadratic or Proportional discharge pressure
 - Adjustable control curve (Max flow and min. static head)
- o Constant Pressure (remote sensor)

Pump Cascade Control

- o Efficiency based pump sequencing
 - * Updated automatically when setpoint and/or control head are changed
- o Automatic Pump alternation (run hour based)
- o Standby Pumps (single or multiple)
- o Adjustable minimum time between starts / stops
- o Adjustable maximum starts per hour
- o Pump test run (exercise idle pumps)
- o Clock program
- o Proportional Gain and Integral Time adjustment

Application optimized functions:

- o Secondary (Fallback) Sensor
- o Pump curve data (5th or 2nd order polynomial)
 - * Pre-programmed from factory
- o Flow estimation via pump curve data and pressure measurement across pump(s)
- o Reduced operation (generator backup power)
 - Max. kW limit or max. number of pumps
- o Specific energy calculation (kWh per unit volume)
 - *requires flow sensor input
- o Low Flow Stop (Pressure Boosting)
 - Adjustable low flow setting: Energy saver mode, medium flow or high comfort level

Protection and Monitoring

- o Check valve failure detection (MLE motors)
- o Pump outside duty range protection
 - *keeps all operating pumps on their curve
- o Low suction pressure warning and alarm
- o Primary sensor failure reaction setting
- o Soft pressure build-up (Pipe fill mode)
- o Low system pressure warning and alarm
- o High system pressure shutdown
- o Alarm log, last 24, time stamped
- o Data log graph (20 - 3600 samples/hour)
 - (Flow, speed, setpoint, sensor feedback, kW)
- o BMS/EMS communication (see page 4)

Grundfos CU 352 Pump Controller

CU 352 Control user interface

Graphical representation of pump status and speed

Alarm and warning indication

System and individual pump status

On screen help

User defined status, up to 3 parameters, sensor feedback, setpoint, power etc.

Estimated Flow

Screen contrast adjustment

Status of inputs and outputs	Alarms and warnings	Startup Wizard																																															
<p>Electrical overview Shows status of inputs along with wiring landing points [in brackets]</p> <p>1.1.1.1 - Analog inputs</p> <table border="1"> <thead> <tr> <th>Input</th> <th>Value</th> </tr> </thead> <tbody> <tr> <td>AI1 (CU 352), [51]</td> <td>35PSI</td> </tr> <tr> <td>(Diff. pressure, pump, high)</td> <td>7.9mA</td> </tr> <tr> <td>AI2 (CU 352), [54]</td> <td>35PSI</td> </tr> <tr> <td>(Diff. pressure, pump, low)</td> <td>7.9mA</td> </tr> <tr> <td>AI3 (CU 352), [57]</td> <td>0PSI</td> </tr> <tr> <td>(Diff. pressure, external)</td> <td>0.0mA</td> </tr> </tbody> </table> <p>1.1.1.2 - Digital inputs</p> <table border="1"> <thead> <tr> <th>Input</th> <th>Status</th> </tr> </thead> <tbody> <tr> <td>DI1 (CU 352), [10]</td> <td>Active</td> </tr> <tr> <td>(External start/stop)</td> <td>Active</td> </tr> <tr> <td>DI2 (CU 352), [12]</td> <td>Not active</td> </tr> <tr> <td>(Reduced operation)</td> <td>Not active</td> </tr> <tr> <td>DI3 (CU 352), [14]</td> <td>Not active</td> </tr> <tr> <td>(Alternative setpoint 2)</td> <td>Not active</td> </tr> <tr> <td>DI1 (I0 351-41), [10]</td> <td>Not active</td> </tr> <tr> <td>(Not used)</td> <td>Not active</td> </tr> </tbody> </table>	Input	Value	AI1 (CU 352), [51]	35PSI	(Diff. pressure, pump, high)	7.9mA	AI2 (CU 352), [54]	35PSI	(Diff. pressure, pump, low)	7.9mA	AI3 (CU 352), [57]	0PSI	(Diff. pressure, external)	0.0mA	Input	Status	DI1 (CU 352), [10]	Active	(External start/stop)	Active	DI2 (CU 352), [12]	Not active	(Reduced operation)	Not active	DI3 (CU 352), [14]	Not active	(Alternative setpoint 2)	Not active	DI1 (I0 351-41), [10]	Not active	(Not used)	Not active	<p>Alarm log - Stores last 24 alarms and warnings.</p> <ul style="list-style-type: none"> > Time event occurred > Time event cleared > Alarm code for more detailed description. <p>3.2 - Alarm log</p> <table border="1"> <thead> <tr> <th>Alarm</th> <th>Occurred at</th> <th>Disappeared at</th> </tr> </thead> <tbody> <tr> <td>AI3-CU352 Sensor fault (88)</td> <td>08/21/2019 10:12 am</td> <td>-- --</td> </tr> <tr> <td>System Water shortage (214)</td> <td>08/21/2019 8:54 am</td> <td>08/21/2019 8:55 am</td> </tr> <tr> <td>System Water shortage (214)</td> <td>08/21/2019 8:54 am</td> <td>08/21/2019 8:55 am</td> </tr> <tr> <td>System Pumps outside duty range (208)</td> <td>08/21/2019 8:54 am</td> <td>08/21/2019 8:54 am</td> </tr> </tbody> </table>	Alarm	Occurred at	Disappeared at	AI3-CU352 Sensor fault (88)	08/21/2019 10:12 am	-- --	System Water shortage (214)	08/21/2019 8:54 am	08/21/2019 8:55 am	System Water shortage (214)	08/21/2019 8:54 am	08/21/2019 8:55 am	System Pumps outside duty range (208)	08/21/2019 8:54 am	08/21/2019 8:54 am	<p>Startup Wizard Step by Step installation guide</p> <ul style="list-style-type: none"> > Set time and date format > Remove air/Prime pumps > Check pump rotation > Set primary sensor <p>17/26 - Priming sequence</p> <p>Close the valve on the outlet side of all the pumps. Prime all pumps and make sure that the suction manifold and the suction pipes are primed as well. Make sure that a correctly sized diaphragm tank has been installed, if necessary, and that the tank precharge pressure is correct. Press [ok] to go to the next page.</p> <p>Go to next page</p>
Input	Value																																																
AI1 (CU 352), [51]	35PSI																																																
(Diff. pressure, pump, high)	7.9mA																																																
AI2 (CU 352), [54]	35PSI																																																
(Diff. pressure, pump, low)	7.9mA																																																
AI3 (CU 352), [57]	0PSI																																																
(Diff. pressure, external)	0.0mA																																																
Input	Status																																																
DI1 (CU 352), [10]	Active																																																
(External start/stop)	Active																																																
DI2 (CU 352), [12]	Not active																																																
(Reduced operation)	Not active																																																
DI3 (CU 352), [14]	Not active																																																
(Alternative setpoint 2)	Not active																																																
DI1 (I0 351-41), [10]	Not active																																																
(Not used)	Not active																																																
Alarm	Occurred at	Disappeared at																																															
AI3-CU352 Sensor fault (88)	08/21/2019 10:12 am	-- --																																															
System Water shortage (214)	08/21/2019 8:54 am	08/21/2019 8:55 am																																															
System Water shortage (214)	08/21/2019 8:54 am	08/21/2019 8:55 am																																															
System Pumps outside duty range (208)	08/21/2019 8:54 am	08/21/2019 8:54 am																																															

Grundfos CU 352 Pump Controller

Sequence of operation

Hydronic Circulation

The system controller shall operate equal capacity variable speed pumps to maintain a variable (quadratic or linear) or constant differential pressure. The system controller shall receive an analog signal [4-20mA] from a remote or pump system mounted differential pressure sensor. The controller shall be able to receive a system suction pressure and system discharge pressure to determine the system differential pressure (two independent analog signals). The controller shall have the means to protect pumps against dry running via a user defined low suction pressure setting.

Pressure Boosting

The system controller shall operate equal capacity variable speed pumps to maintain a constant or variable (quadratic or linear) pressure. The system controller shall receive an analog signal [4-20mA] from a remote or pump system mounted pressure sensor. The controller shall be capable of simulating the effect of a remote mounted pressure sensor by quadratically reducing the system discharge pressure setpoint as a function of reduced flow (friction loss compensation).

Cascade Control

Standard Cascade Control (Pumping Efficiency Based):

The pump system controller shall adjust pump speed as necessary to maintain system set-point pressure as flow demand changes. The pump system controller shall start additional pumps upon determination of an increase in efficiency utilizing factory programmed (5th order polynomial) curve data. When the system pressure is equal to the system set-point, all pumps in operation shall reach equal operating speeds. The pump system controller shall have field adjustable Proportional gain and Integral time (PI) settings for system optimization.

Optional Cascade Control (Pump Start Speed Based):

As flow demand increases the pump speed shall be increased to maintain the system set-point pressure. When the operating pump(s) reach the programable start speed, an additional pump will be started and will increase speed until the system set-point is achieved. When the system pressure is equal to the system set-point, all pumps in operation shall reach equal operating speeds. The pump system controller shall have field adjustable Proportional gain and Integral time (PI) settings for system optimization.

Pumps outside duty range (End of curve protection):

When the pumps are outside their allowable operating range, the controller shall switch on an additional pump, distributing a reduced flow through all pumps in operation moving each pump back into its allowable operating region.

Pump Alternation

All pumps in the system shall alternate automatically based on demand, time and fault. If flow demand is continuous with only one pump in operation, the system controller shall have the capability to alternate the pumps every 24 hours, every 48 hours or once per week. The interval and actual time of the pump change-over shall be field adjustable.

Low Flow Stop (Pressure Boosting)

The system controller shall be capable of detecting low flow allowing for pumps to be switched off in an energy saving mode. Upon detection of low flow, the controller shall increase the system setpoint by 5% (adjustable) to store water in a diaphragm or bladder tank and switch off. The pump shall remain off until the system pressure falls 5% below the system setpoint (adjustable). If system flow is still low when the pump switches back on, the pump shall refill the diaphragm tank to 5% above setpoint and switch off again. If system flow increases above the low flow setting, the pump shall return to normal constant pressure mode maintaining the system setpoint.

Grundfos CU 352 Pump Controller

Technical data

Altitude above sea level

Maximum 6,560 feet (2000 m.)

Ambient Temperature

During operation: -4°F to +140°F (-20°C to +60°C)

During transportation: -4°F to +140°F (-20°C to +60°C)

- * At temperatures below 32°F (0°C) the display may react slowly.
- * The display should not be exposed to direct sunlight

Relative air humidity

5 to 95%

Enclosure class

UL type 3R when mounted in the front of a panel with UL type rating 1, 2, 3, 3R, 5, 12, 12K or 13. Overall control panel rating of Type 4/4X available on request.

Supply voltage

1 x 100-240 VAC +/- 10% 50/60Hz, PE
(Class 1 equipment)

Power consumption

Maximum 22 W

Backup battery

The optional backup battery can keep the CU352 powered during intermittent power outages.

The CU 352 will monitor the following:

- short circuit
- wrong polarity
- defective battery
- battery missing
- low battery voltage

Digital inputs (3)

Open-circuit voltage	24 VDC
Closed-circuit current	5 mA, DC
Frequency range	0-4 Hz

Analog inputs (3)

	0-20 mA
Input current and voltage	4-20 mA
	0-10 V
Tolerance	± 3.3 % of full scale
Repetitive accuracy	± 1 % of full scale
Input resistance, current	< 250 Ω
Input resistance, voltage	> 50 kΩ ± 10%
	24 V, 30 mA
Supply to sensor	short-circuit protected

Relay outputs (2)

Normally open contacts	C, NO
Maximum contact load	240 VAC, 2 A
Minimum contact load	5 VDC, 10 mA

Communication protocols

For connection to building management systems, Communication Interface Modules (CIM) can be supplied with the CU 352 controller.

Protocol	CIM Type
LONworks	110
PROFIBUS DP	150
PROFINET IO	500
Modbus RTU	200
Modbus TCP	500
BACnet MS/TP	300
BACnet IP	500
Ethernet IP	500

MLE

Product compatibility

- **Multi-stage:** CRE, CRIE, CRNE, MTRE, MTSE, SPKE, CME
- **Single-stage:** TPE2, TPE3, VLSE, LCSE
- **Systems:** Hydro MPC-E, Hydro Multi-E, Hydro Multi-B, Hydro Solo-E, CMBE home booster.



TM06 5684 2219

MLE is a dedicated motor-drive system for pumps and other applications. Pumps equipped with MLE motors overcome application challenges and save energy in a variety of pump installations in order to reach the lowest Life Cycle Cost (LCC) possible.

Integrated drives

Integrated drives are beneficial because they are installed on non-controlled pumps at no additional installation cost. Once the power supply is connected and the pump is fitted into the pipe system, they are ready to operate at the desired setpoint.

Operating pumps with MLE also reduces CAPEX (capital expense) of additional cabinets, components and facility space by having the entire pump system in line with the pipe system.

MLE is the result of Grundfos' efficient motor technology and it is an efficient IE5 motor, with an efficiency much higher than NEMA Premium, which minimizes OPEX (operating expense).

Robustness throughout the system

The Grundfos full line supply of components, from the power supply to pipe fittings, provides the most robust solutions:

- Built-in protection against power supply disturbances, environment and motor load.
- MLE is designed to mitigate bearing currents.
- No cooling fans in drive (wear part).

MLE product range

1 x 200-240 V	0.33 - 2.0 HP
3 x 200-240 V	1.5 - 7.5 HP
3 x 440-480 V	0.33 - 15 HP*

* Up to 30 HP available with different specifications.

Features and benefits

Feature	Benefit
Application control	
Control modes	Easy commissioning to match system design criteria.
Multipump function including alternating, back-up, or cascade	Neglects the need for external controllers and continuous operation by redundant pump and sensor if either component fails.
Differential pressure or temperature with 2 sensors	Lower CAPEX by common inexpensive sensor types.
Pump curve adjustments and run at power limit	Stabilizes unstable pump curves and extends operating range.
Setpoint influence	Adapts QH to internal or measured values.
Energy saving for lower OPEX	
AUTOADAPT or FLOWLIMIT	Continuously adapts to the most efficient curve and reduces pressure loss in the system.
Low-flow stop function	Improved energy optimization and comfort.
ECM motor that exceeds the NEMA Premium efficiency levels	ECM motors have significantly lower motor loss than NEMA Premium motors. This alone reduces energy consumption by 10 % with a typical pump load profile.
Condition monitoring	
Limit Exceed function	Any value can be supervised to protect the system.
Loss of prime and dry run	Protects the shaft seal.
Cavitation protection	Protects the impellers.
Flow estimate and heat energy monitor	Monitoring of the heating system's performance.
Overload and temperature	Protects the frequency converter and motor.
Stop at minimum speed	Protects the pump and saves energy.
Motor bearings monitors	Ensures uptime by preventive maintenance.
Robustness	
Operating temperature between -4 and +140 °F	Allows installation almost anywhere and high margins in control rooms, resulting in longer product service life.
Impulse transient resistance (VDE0160 compliant)	Resistance against lightning, ESD, switching impulses and utility fault clearing.
Interruptions and voltage sags (SEMIF47 compliant)	Keeps process running and derates the pump to the available power.
Line harmonics resistance (EN 61000-4-13, class 3)	Built-in compensation of disturbance to avoid overheating of motor windings and maintaining a steady pump operation.
Built-in RFI filters	Neglects the need for external components.
NEMA3 / NEMA4 enclosures	Installed in-line to pipe systems at no added cost.

Grundfos iSOLUTIONS

Grundfos iSOLUTIONS delivers the optimal combination of pumps, drives and auxiliary components for the specific application, incorporating special features and functions, and building on application knowledge and experience.

Grundfos iSOLUTIONS allows easy integration of pumps, drives, measurements, controls, protections, and communication, saving you valuable engineering, installation and commissioning time.

To learn more, visit: www.grundfos.com/isolutions

Sensors

MLE is sensor-independent and controls the pump to any measured feedback.

Grundfos offers several sensors to be used in pump solutions:

- pressure sensors
- temperature sensors
- differential pressure sensors
- differential temperature sensors
- flow meters.

Grundfos GO Remote

Grundfos GO Remote for iOS and Android ensures easy and quick commissioning, monitoring and servicing of pumps with MLE motors.



TW07 4786 2419

Technical specifications

Motor data			
	Operating range (rpm)	Constant power (rpm)	Constant torque (rpm)
Speed range	180-2000	1740-2000	900-1740
	360-4000	3480-4000	1750-3480
	360-4000	3400-4000	2000-3400
	500-5900	4000-5900	-
Voltage tolerances	± 10 %		
Frequency	50-60 Hz ± 5 %		
Network	TN/TT (optional: IT) according to IEC 60364		
Environmental limits			
Degree of protection	NEMA3 / NEMA4		
Operating temp.	-4 to +140 °F derating above 122 °F		
Storage temp.	-4 to +140 °F		
Altitude	0-3280 ft without derating / 0-11480 ft with derating		
Humidity	0-95 %, non-condensing		
Inputs/outputs	FM100	FM200	FM300
Digital inputs	1	1	2
Digital inputs/ outputs	1	1	2
Relay outputs	-	2	2
Analog inputs	1 (only V)		
Pt100/Pt1000 inputs	-	-	2
+5 V supply	Y	Y	Y
+24 V supply	-	Y	Y
Grundfos Digital Sensor input	-	Y	Y
LiqTec sensor input	-	-	Y
Digital inputs (dedicated)	0-5 V		
Digital inputs/ outputs	0-24 V, resistive or inductive		
Analog input	0-20 mA / 4-20 mA, 0.5 - 3.5 V / 0-5 V / 0-10 V		
Relay output	250 V AC/30 V DC, max. continuous current 2 A rms		
Connectivity			
Wireless (radio)	Yes, GENlair		
RS-485	Yes, GENlair		
Communication options	• LONWorks (CIM 100)		
	• PROFIBUS DP (CIM 150)		
	• Modbus RTU (CIM 200)		
	• GSM/GPRS (CIM 250)		
	• 3G/4G cellular (CIM 260)		
	• GiC/GRM 3G/4G (CIM 280)		
	• BACnet MS/TP (CIM 300) PROFINET IO (CIM 500)		
	• Modbus TCP (CIM 500)		
	• BACnet IP (CIM 500)		
	• Ethernet IP (CIM 500)		
Compliance			
Conformity to standards	CE, EAC, RCM, CCC, and cURus (UL)		
Harmonics	IEC/EN 61000-3-12		
EMC	Up to 10.0 HP (7.5 HP low speed): Category C1 according to EN 61800-3, corresponding to CISPR 11, class B (residential area)		
	Above 10.0 HP (7.5 HP low speed): Category C3 according to EN 61800-3, corresponding to CISPR 11, class A, group 2 (industrial area)		

99689406 0719

ECM: 1264915

Vibration Isolation

Common vibration concerns with frame mounted end suction pumps

- Misalignment between motor shaft and pump shaft is the #1 source of pump vibration
 - o End suction pumps typically have large over-hung impellers with high rotating inertia, that when misaligned creates large unbalanced forces and results in vibration
 - o Offset discharge throat of the volute creates the radial load
 - o Decreased component life
- End suction pump bearing loading is primarily from radial forces

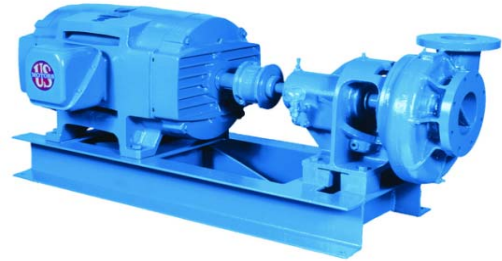

Unbalanced forces and increased vibration

Grundfos CR Multistage pump benefits:

- Register fit between motor and pump
- No alignment required for lifetime of operation
- Minimized vibration
- Longer component life
- Quiet operation (product lubricated pump bearings)
- CR Multistage pumps offer the lowest rotating inertia compared to most other pumps in same duty conditions
- Low rotating inertia equals less opportunity for vibration
- Multistage pump bearing loading is on average 10% radial and 90% axial forces



No alignment is required

Pump systems with Grundfos CR(E) Multistage pumps

- Vibration Isolation:
 - o 1/2" thick dampeners at pump base mounting points (4 per pump)
 - o Inertia bases and grouting are not required when mounted to concrete housekeeping pad
 - o Flexible connectors on manifold connections are recommended

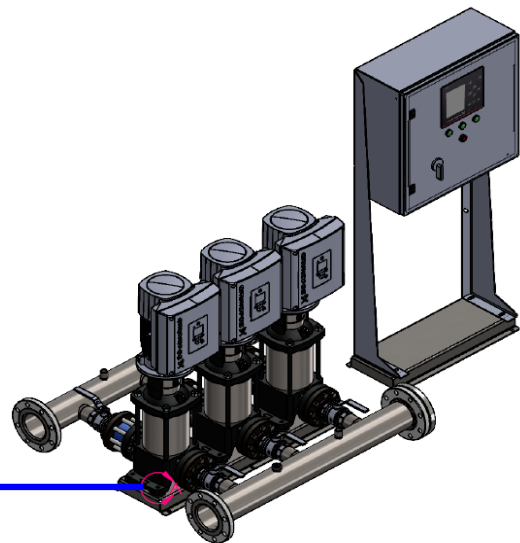
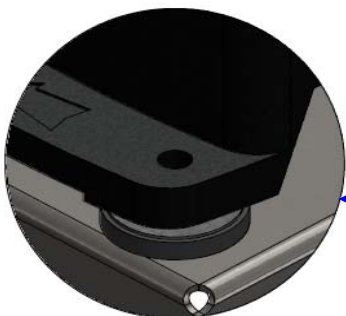

GRUNDFOS

Panel Part Number:
99554616

Description
Control MPC E
3 X 3HP
3 X 480V

Selected Options: System Fault Light, Audible Alarm, Surge Protection, Pump Run Light, Normal/Emergency Switch, Service Disconnect Switch

0	4/17/2019	Control MPC E 3 X 3HP 3 X 480V	This drawing and its content is the property of GRUNDFOS. It may not be copied for third parties or competitors. Changes are only to be made by GRUNDFOS.	PROJECT:	99554616	GRUNDFOS 
1	9/9/2019			EDW-WD-GPC-1017	Panel Part Number: 99554616	
ECM/Rev	Date					

Feeder Circuit Protection:

Feeder circuit protection to be provided by others.
Type and size to be based on local, state and national electrical codes

SCCR Rating: 100 kA RMS Symmetric,
480V

UL Type Rating: 3R

Largest Motor FLA and Panel Maximum FLA:

Motor Horsepower	3HP
Motor FLA	3.8FLA
Panel Max. FLA	12.4FLA

Wire Type	Color	Abbr.
+12/24VDC Power/PLC Input(s)	Blue	BU
-12/24VDC Power/PLC Input(s)	Blue w/White Stripe	BUWH
115VAC Primary Line Power	Black	BK
115VAC Neutral	White	WH
Ground/PE	Green/Yellow Stripe	GNYE
Analog Inputs	Orange	OG
Analog Outputs	Orange	OG
Digital Inputs (CU Components)	Violet	VT
Ground for Digital Inputs (CU Components)	Violet w/White Stripe	VTWH
Digital Outputs	Yellow	YE
Power L1	Black	BK
Power L2	Orange	OG
Power L3	Red	RD
Power Neutral	White	WH
All Other Wiring	Brown	BN

Safety / Application Notes:

**** Please Reference the "BOOSTERPAQ - HYDRO MPC"**

Installation and Operation Instructions "BEFORE" Applying power to Panel.

** Power supply wires in front of main disconnect switch have dangerous voltage even though the main disconnect switch is off.



** Control panel must be connected professionally to the earth / ground.

** GRUNDFOS MLE motors have an integrated variable frequency drive (VFD) which provides motor overload protection. If a system utilizes MLE motors, the motor overload protection is provided by the VFD and does not require any additional motor overload protection.

Cross Reference Definition

(##-##)
Sheet-Row

Wire Types

Internal Panel Wire 
External Wire 

0	4/17/2019
1	9/9/2019
ECM/Rev	Date

Control MPC E
3 X 3HP
3 X 480V

This drawing and its content is the property of GRUNDFOS. It may not be copied for third parties or competitors. Changes are only to be made by GRUNDFOS.

PROJECT: 99554616

EDW-WD-GPC-1017



Panel Part Number: 99554616

SHEET: 2/11

1 1-Table of Contents

2	Drawing	Revision	Date	Created by	Description
3	<u>01</u>	0	4/17/2019	jharvey	Cover Page 01
4	<u>02</u>	0	4/17/2019	jharvey	Cover Page 02
5	<u>03</u>	0	4/17/2019	jharvey	Drawings list
6	<u>04</u>	0	4/17/2019	jharvey	Power 01
7	<u>05</u>	0	4/17/2019	jharvey	Power 02
8	<u>06</u>	0	4/17/2019	jharvey	Control 01
9	<u>07</u>	0	4/17/2019	jharvey	Control 02
10	<u>08</u>	0	4/17/2019	jharvey	Panel Layout
11	<u>09</u>	0	4/17/2019	jharvey	Panel Views
12	<u>13</u>	0	5/20/2019	kharen	Bill Of Materials grouped by manufacturer Rev1.0 (Components)
13	<u>14</u>	0	5/20/2019	kharen	Bill Of Materials grouped by manufacturer Rev1.0 (Components)
14	12	0	4/17/2019	jharvey	Main electrical closet

21
22
23
24
25
26
27
28
29
30
31
32
33
34
35

0	4/17/2019	Control MPC E 3 X 3HP 3 X 480V	This drawing and its content is the property of GRUNDFOS. It may not be copied for third third parties or competitors. Changes are only to be made by GRUNDFOS.	PROJECT: 99554616
1	9/9/2019			
ECM/Rev	Date			EDW-WD-GPC-1017

GRUNDFOS 	
Panel Part Number: 99554616	SHEET: 3/11

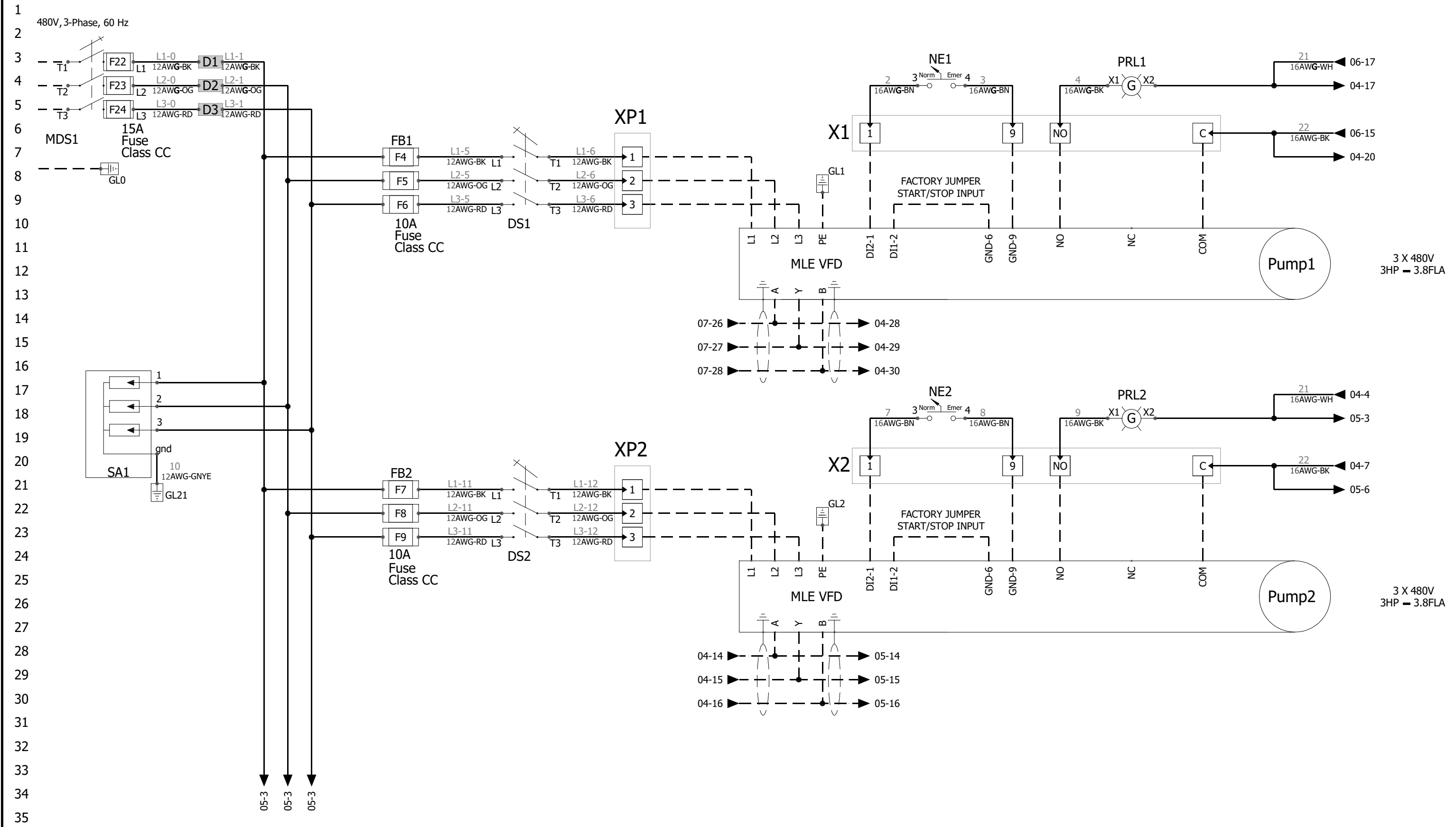

0	4/17/2019
1	9/9/2019
ECM/Rev	Date

Control MPC E
3 X 3HP
3 X 480V

This drawing and its content is the property of GRUNDFOS. It may not be copied for third parties or competitors. Changes are only to be made by GRUNDFOS.

PROJECT: 99554616

EDW-WD-GPC-1017

GRUNDFOS

Panel Part Number: 99554616

SHEET: 4/11

1
2
3
4
5
6
7
8
9
10
11
12
13
14
15
16
17
18
19
20
21
22
23
24
25
26
27
28
29
30
31
32
33
34
35

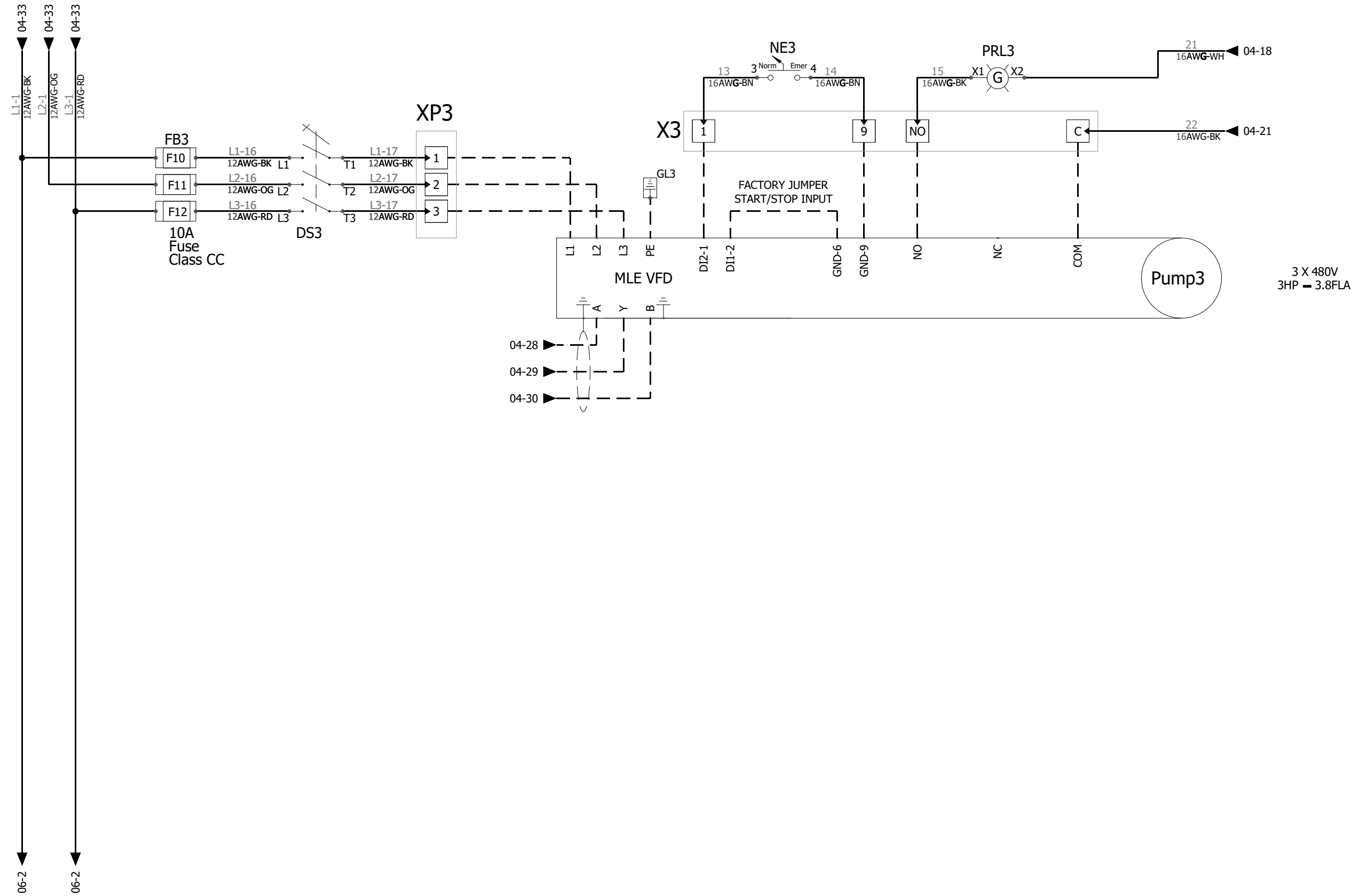

0	4/17/2019	Control MPC E 3 X 3HP 3 X 480V	This drawing and its content is the property of GRUNDFOS. It may not be copied for third parties or competitors. Changes are only to be made by GRUNDFOS.	PROJECT:	99554616	
1	9/9/2019			EDW-WD-GPC-1017	Panel Part Number: 99554616	
ECM/Rev	Date					

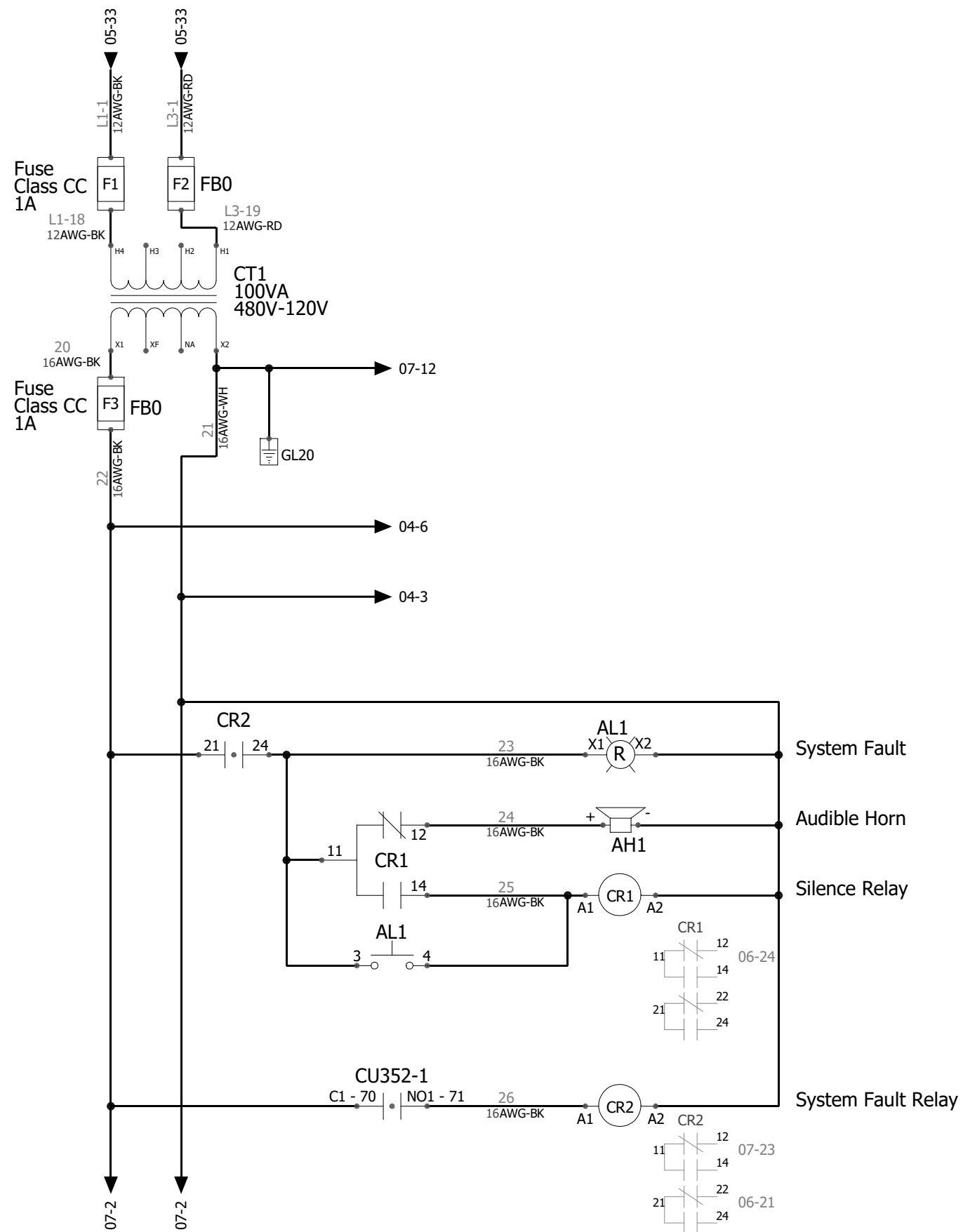

1
2
3
4
5
6
7
8
9
10
11
12
13
14
15
16
17
18
19
20
21
22
23
24
25
26
27
28
29
30
31
32
33
34
35

0	4/17/2019	Control MPC E 3 X 3HP 3 X 480V	This drawing and its content is the property of GRUNDFOS. It may not be copied for third parties or competitors. Changes are only to be made by GRUNDFOS.	PROJECT: 99554616	EDW-WD-GPC-1017	
1	9/9/2019					
ECM/Rev	Date					Panel Part Number: 99554616
						SHEET: 6/11

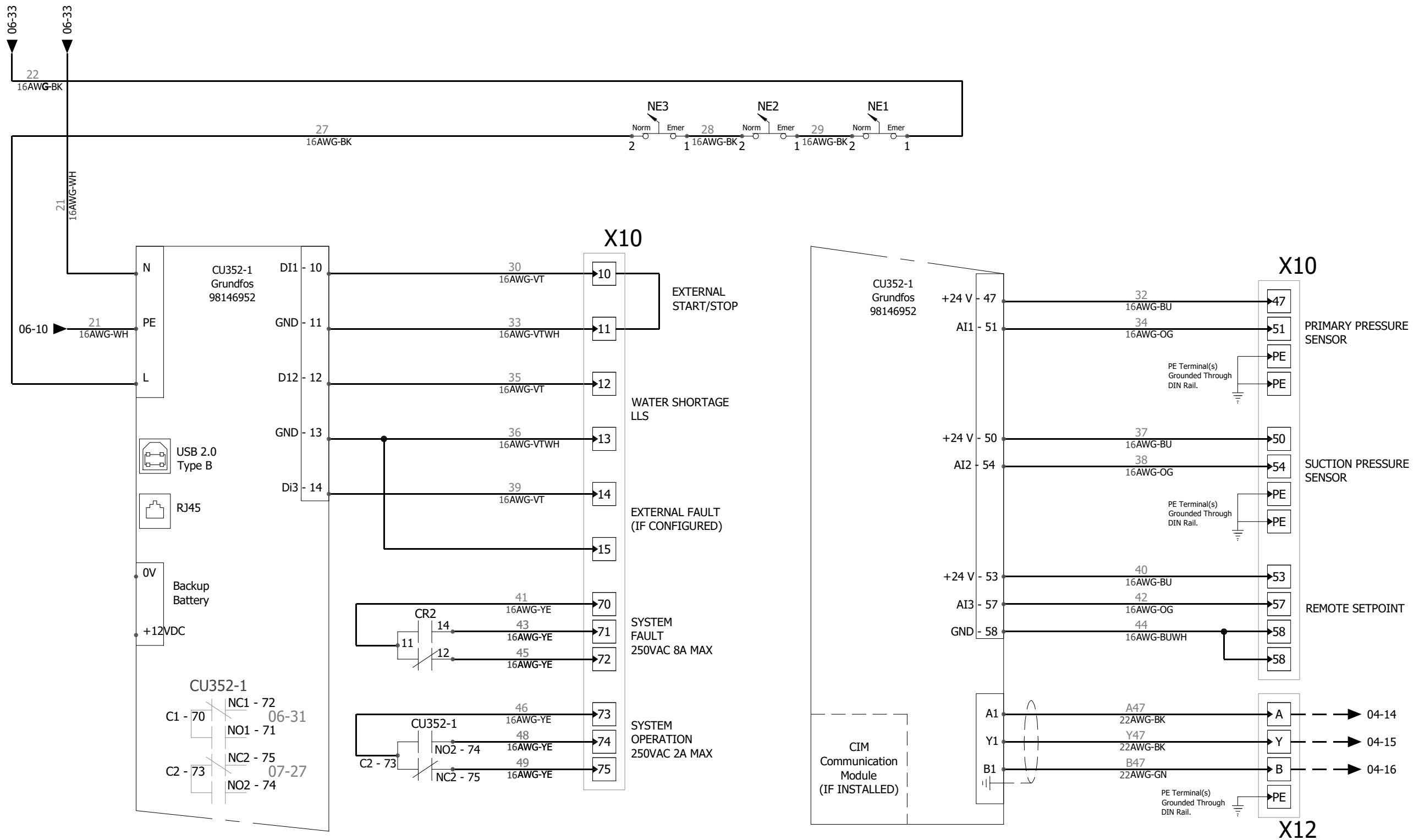

CIM COMMUNICATION MODULE TERMINATIONS

CIM	Terminal 1	Terminal 2	Terminal 3	Terminal 4
CIM 110	LON	LON terminal A	LON terminal B	LON terminal for cable screen
CIM 150	PROFIBUS DP	PROFIBUS terminal B	PROFIBUS terminal A	PROFIBUS terminal DGND
CIM 200	Modbus RTU	Modbus terminal D1	Modbus terminal D0	Modbus terminal common/GND
CIM 300	BACnet MS/TP	BACnet Plus terminal	BACnet Minus terminal	BACnet Ground terminal
CIM 500	BACnet IP, Modbus TCP, PROFINET IO	RJ45	RJ45	

0	4/17/2019
1	9/9/2019
ECM/Rev	Date

Control MPC E
3 X 3HP
3 X 480V

This drawing and its content is the property of GRUNDFOS. It may not be copied for third parties or competitors. Changes are only to be made by GRUNDFOS.

PROJECT: 99554616

EDW-WD-GPC-1017



Panel Part Number: 99554616

SHEET: 7/11

1
2
3
4
5
6
7
8
9
10
11
12
13
14
15
16
17
18
19
20
21
22
23
24
25
26
27
28
29
30
31
32
33
34
35

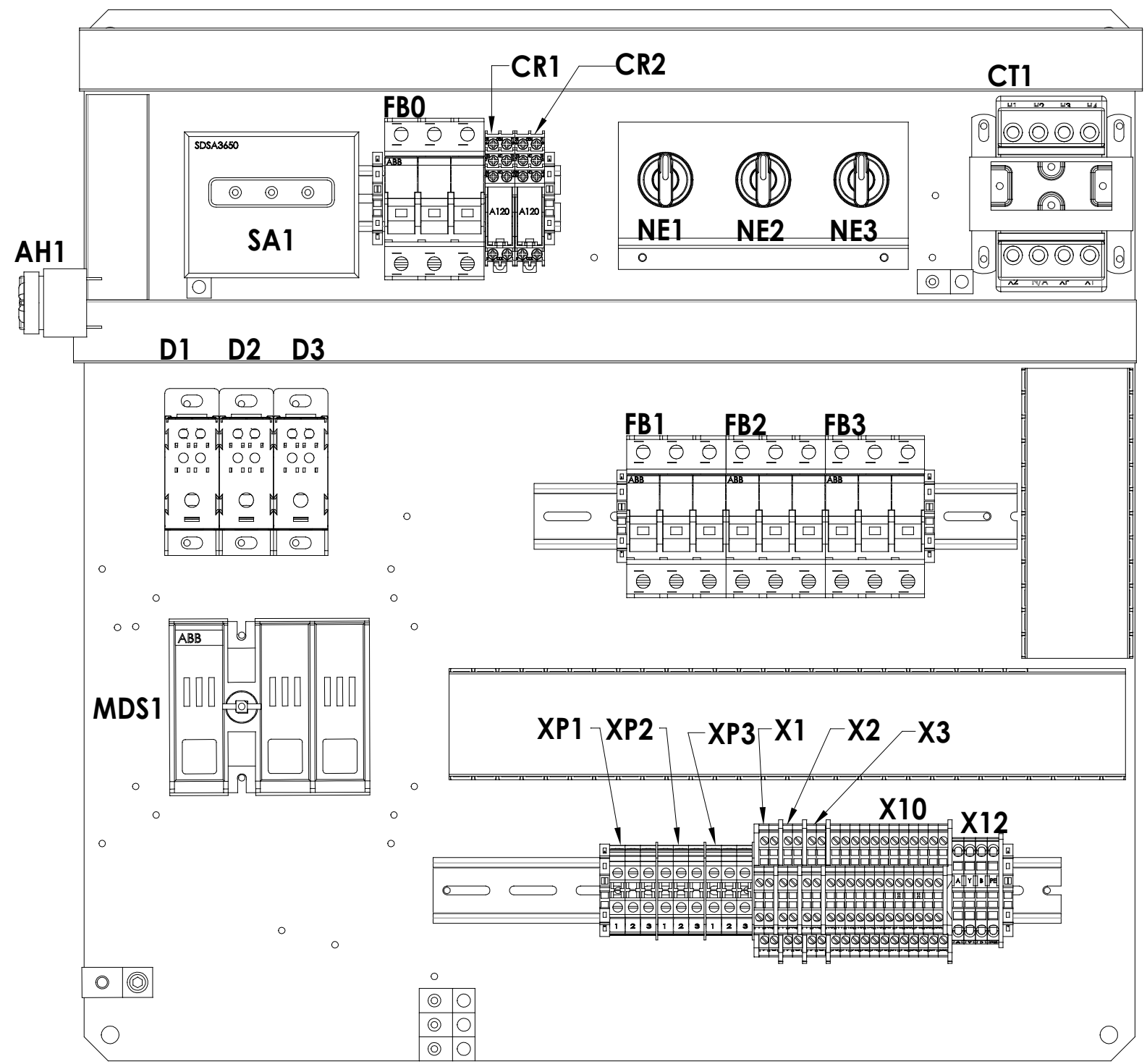

0	4/17/2019
1	9/9/2019
ECM/Rev	Date

Control MPC E
3 X 3HP
3 X 480V

This drawing and its content is the property of GRUNDFOS. It may not be copied for third parties or competitors. Changes are only to be made by GRUNDFOS.

PROJECT: 99554616
 EDW-WD-GPC-1017

GRUNDFOS 

Panel Part Number: 99554616 SHEET: 8/11

1
2
3
4
5
6
7
8
9
10
11
12
13
14
15
16
17
18
19
20
21
22
23
24
25
26
27
28
29
30
31
32
33
34
35

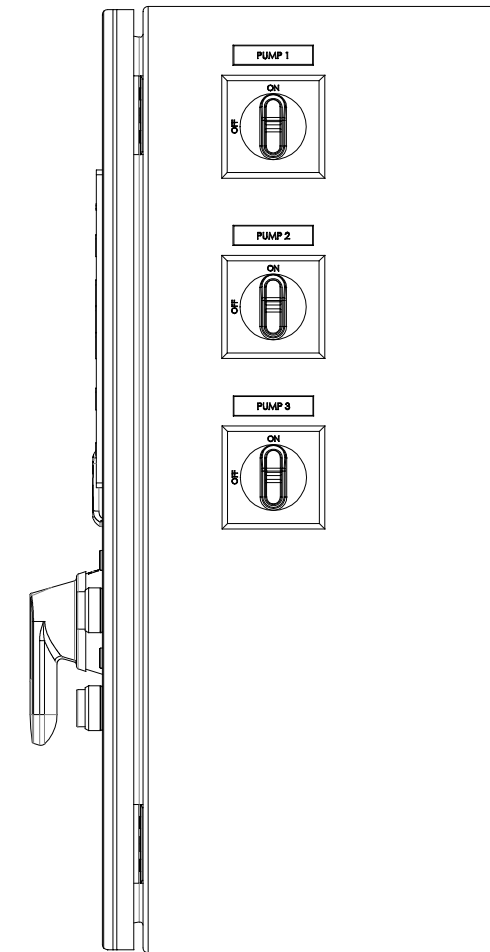
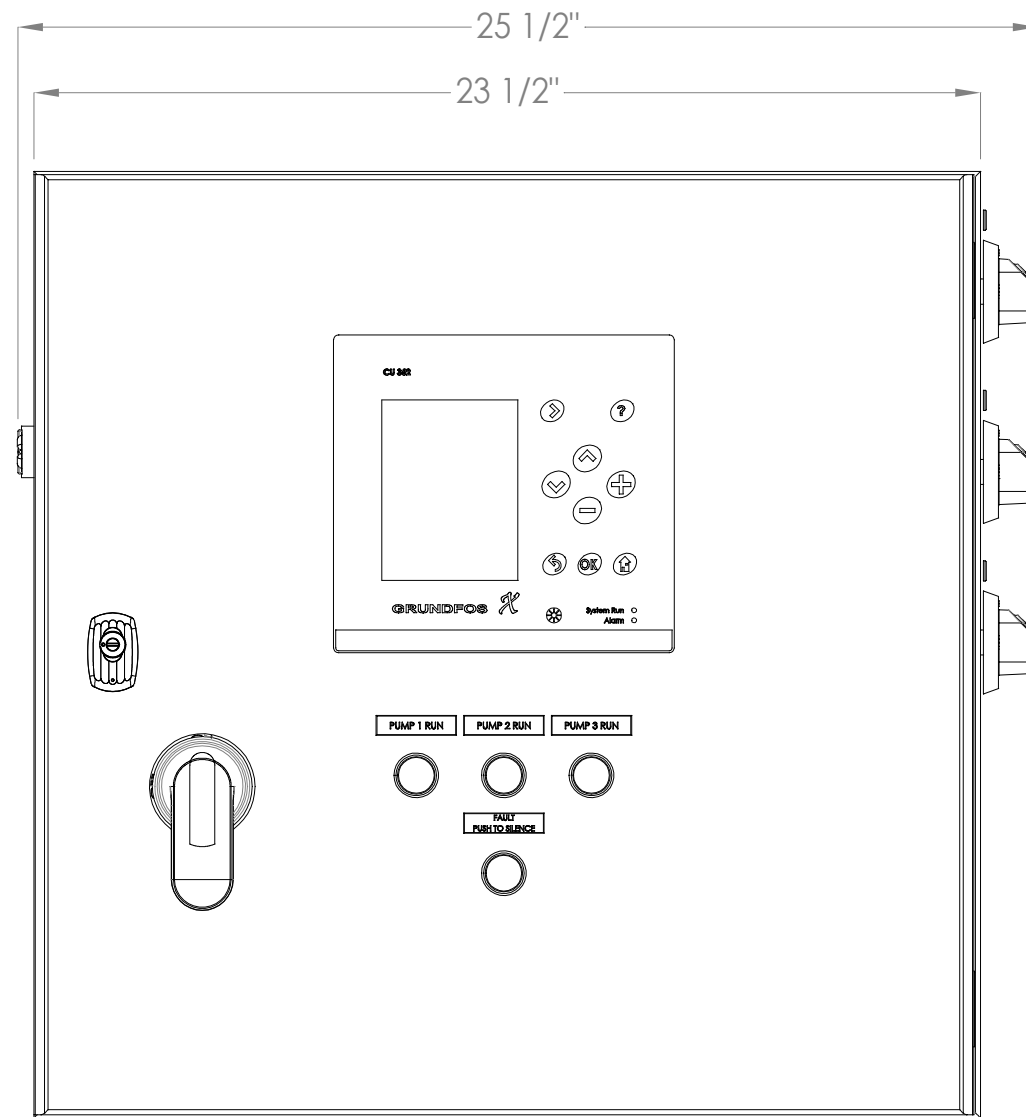
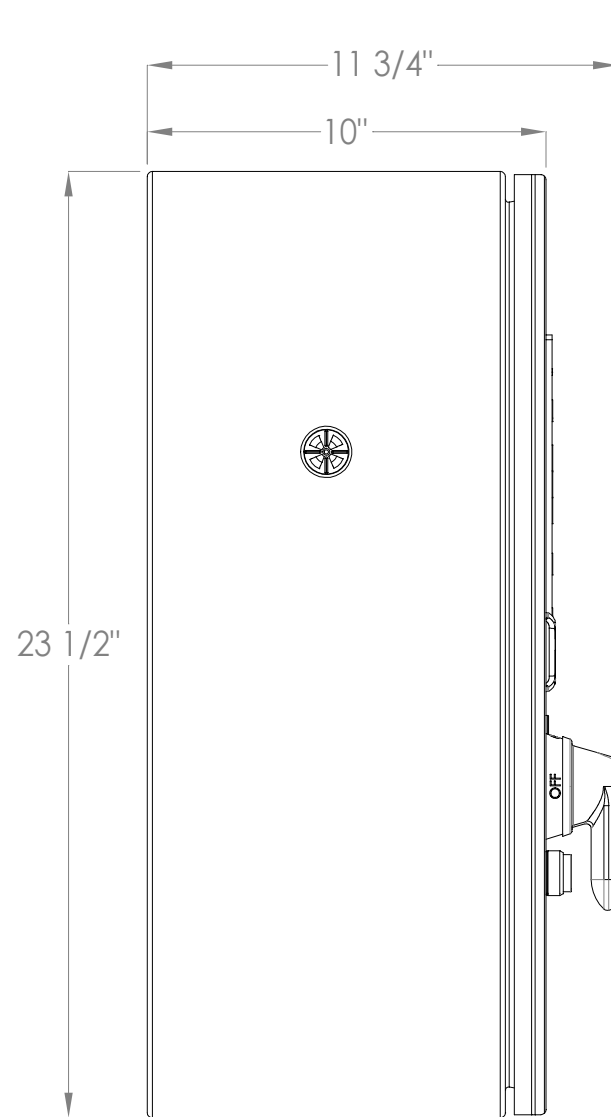

CLEARANCE FROM FRONT OF ENCLOSURE MUST BE 36"
CLEARANCE FROM DISCONNECT HANDLES MUST BE 6"

0	4/17/2019
1	9/9/2019
ECM/Rev	Date

Control MPC E
3 X 3HP
3 X 480V

This drawing and its content is the property of GRUNDFOS. It may not be copied for third parties or competitors. Changes are only to be made by GRUNDFOS.

PROJECT: 99554616

EDW-WD-GPC-1017



Panel Part Number: 99554616

SHEET: 9/11

1
2
3
4
5
6
7
8
9
10
11
12
13
14
15
16
17
18
19
20
21
22
23
24
25
26
27
28
29
30
31
32
33
34
35

Article Number	Mark	Manufacturer	Reference	Description	Quantity	Component Type
13-16-26-1241	FB0 , FB1 , FB2 , FB3	ABB	E9330CCS	Fuse Block; 3P, 30 A, Class CC, Indicator, Padlockable	4	Fuse Block 3-pole
13-16-66-1615	<u>MDS1</u>	ABB	OHY80L6	Disconnect Handle; Red/Yellow, 30/60/100/250A, Type 4, 4X, 3R, 12	1	Main Disconnect
13-16-66-1348	DS1 , DS2 , DS3	ABB	OHYS2RJ	Disconnect Handle; Red/Yellow, for Side Mount, Type 3R, 12	3	Service Disconnect
13-16-66-1506	<u>MDS1</u>	ABB	OHZX10	Alignment Ring; Use on all Pistol Grip Handles	1	Main Disconnect
13-16-66-1431	<u>MDS1</u>	ABB	OS30FACC12	Disconnect Switch; 30A, Fuseable, 600V, 3-Pole, UL98, Class CC, Center Shaft	1	Main Disconnect
13-16-66-1383	DS1 , DS2 , DS3	ABB	OT63FT3	Disconnect Switch; 60A, 600V, 3-Pole, Front Mount	3	Service Disconnect
13-16-66-1610	<u>MDS1</u>	ABB	EXP6X500	Disconnect Shaft; 19.7", 6x500	1	Main Disconnect
13-16-81-1463	<u>CT1</u>	Acme	TB100A005C	Transformer; 100VA, P/208/230/460V, S/115V	1	Controls Transformer
13-16-26-1060	F1 , F2 , F3	F.Shaw	ATQR1	Fuse; 1A, 600V, 13/32" x 1 1/2", Class CC	3	Fuse
13-16-26-1066	F4 , F5 , F6 , F7 , F8 , F9 , F10 , F11 , F12	F.Shaw	ATQR10	Fuse; 10A, 600V, 13/32" x 1 1/2", Class CC	9	Fuse
13-16-26-1068	F22 , F23 , F24	F.Shaw	ATQR15	Fuse; 15A, 600V, 13/32" x 1 1/2", Class CC	3	Fuse
13-16-71-1536	D1 , D2 , D3	F.Shaw	FS PDB 2A	Distribution block; 175A, 600V, 1in/4out	3	Distribution Block
13-16-56-1029	<u>AH1</u>	Floyd Bell	SP-1081	Alarm; 120V, 95db, Reduced Sensitivity, Extra Fast Warble, Panel Mount	1	Audible Horn
13-16-39-1093	<u>CU352-1</u>	Grundfos	98146952	(CM) Logic Module; Grundfos MPC Controller (CU352)	1	CU352
13-16-46-1073	CR1 , CR2	Idec	RJ2S-CL-A120	Relay; 120V, DPDT, 8A, Indicator	2	Silence Relay , System Fault Relay
13-16-46-1283	CR1 , CR2	Idec	SJ2S-07LW	Socket; 8 Pin, DIN/Pnl Mt, for RJ Relays	2	Silence Relay , System Fault Relay
13-66-11-1130	SAB1	OSI	13-66-11-1130	Bracket; Surge Arrestor	1	SA Bracket
65-BP-2424-A01	L1	OSI	65-BP-2424-A01	Backplate; 24x24, Aluminum, Pre-Drilled, Layout 01	1	Main electrical closet
65-ELEC-BRKT-3HOA	SWB1	OSI	65-ELEC-BRKT-3HOA	Bracket; HOA or N/E Switch, x3	1	NE Bracket
65-LIGHT-1R-032	<u>AL1</u>	OSI	65-light-1R-032	Push Button Light; Fault, Push to Silence	1	System Fault
65-SWITCH-2-12	NE1 , NE2 , NE3	OSI	65-SWITCH-2-12	Switch; Two Position, 1-NO, 1-NC	3	Normal/Emergency Switch
65-TB-CU352-DB	<u>X10 1</u>	OSI	65-TB-CU352-DB	Terminal Blocks; Double Stack, X10 CU352 Terminals	1	CU352 Terminal Blocks

0	4/17/2019
1	9/9/2019
ECM/Rev	Date

Control MPC E
3 X 3HP
3 X 480V

This drawing and its content is the property of GRUNDFOS. It may not be copied for third parties or competitors. Changes are only to be made by GRUNDFOS.

PROJECT: 99554616
 EDW-WD-GPC-1017



GRUNDFOS

Panel Part Number: 99554616	SHEET: 13/11
-----------------------------	--------------

1
2
3
4
5
6
7
8
9
10
11
12
13
14
15
16
17
18
19
20
21
22
23
24
25
26
27
28
29
30
31
32
33
34
35

Article Number	Mark	Manufacturer	Reference	Description	Quantity	Component Type
65-TB-GENI	X12 1	OSI	65-TB-GENI	Terminal Blocks; X12 Geni Bus Terminals	1	Geni Bus Terminal Blocks
65-TB-PT-50A	XP3 1 , XP2 1 , XP1 1	OSI	65-TB-PT-50A	Terminal Blocks; Single Pump Pass Through, 50A	3	Pump Power Terminal Blocks
65-TB-SINGLE-PUMP-DB	X3 1 , X1 1 , X2 1	OSI	65-TB-SINGLE-PUMP-DB	Terminal Blocks; MLE Pump Control	3	Pump Control Terminals
13-16-86-1680	GL0 , GL1 , GL2 , GL3 , GL20 , GL21	Raco	TA2-Bulk	Ground Lug; 2AWG, Burndy	6	Ground Lug
13-16-61-1010	SA1	Schneider	SDSA 3650	Surge Arrestor; 3 Phase, 600V, WYE	1	Surge Arrestor
65-ENCL-2424-RSH	L1	Schneider Electric	65-ENCL-2424-RSH	Enclosure; 24X24 Right Side Hinge	1	Main electrical closet
13-16-36-1421	PRL1 , PRL2 , PRL3	Siemens	3SU11036AA401AA0	Pilot Light; Green, 110 VAC Complete	3	Pump 1 Run Light , Pump 2 Run Light

0	4/17/2019
1	9/9/2019
ECM/Rev	Date

Control MPC E
3 X 3HP
3 X 480V

This drawing and its content is the property of GRUNDFOS. It may not be copied for third third parties or competitors. Changes are only to be made by GRUNDFOS.

PROJECT: 99554616
 EDW-WD-GPC-1017



Panel Part Number: 99554616	SHEET: 14/11
-----------------------------	--------------