

Pump Performance Datasheet

Customer :	Quote Number / ID : 74718
Customer ref. / PO :	Model : Hydro MPC-E 2CRE 125-1-1 3x460V
Tag Number : 001	60Hz
Service :	Part Number : Custom system
Quantity : 1	Stages : 1
Quantity of pumps : 2 active + 0 standby	Based on curve number : E125-1-1
	Date last saved : 10/03/2022 4:04 AM

Operating Conditions		Liquid	
System flowrate	: 1,090.3 USgpm	Liquid type	: Cold Water
Flowrate per pump	: 545.2 USgpm	Additional liquid description	:
Differential head / pressure, rated (requested)	: 92.75 ft	Temperature, max	: 68.00 deg F
Differential head / pressure, rated (actual)	: 92.75 ft	Fluid density, rated / max	: 1.000 / 1.000 SG
Suction pressure, min / max	: 0.00 / 0.00 psi.g	Viscosity, rated	: 1.00 cP
NPSH available, rated	: Ample	Vapor pressure, rated	: 0.34 psi.a
Site Supply Frequency	: 60 Hz		
Power Supply	: 3ph 460V		

Performance		Material	
Speed, rated	: 3600 rpm	Material selected	: Standard - Cast Iron / 304
Speed, maximum	: 3600 rpm		Stainless Steel
Speed, minimum	: 900 rpm		
Pump efficiency	: 76.77 %		
NPSH required / margin required	: 13.20 / 0.00 ft		
nq (imp. eye flow) / S (imp. eye flow)	: 54 / 235 Metric units		
Head maximum, rated speed	: 123.0 ft		
Head rise to shutoff	: 32.61 %		
Flow, best eff. point	: 545.2 USgpm		
Flow ratio, rated / BEP	: 100.00 %		
Speed ratio (rated / max)	: 100.00 %		
Head ratio (rated speed / max speed)	: 100.00 %		
Cq/Ch/Ce/Cn [ANSI/HI 9.6.7-2010]	: 1.00 / 1.00 / 1.00 / 1.00		
Selection status	: Acceptable		

Pressure Data		Driver & Power Data (@Max density) (Per Pump)	
Pump shut off pressure	: 53.23 psi.g	Motor sizing specification	: Max power (non-overloading)
Maximum allowable suction pressure	: 145.0 psi.g	Margin over specification	: 0.00 %
		Service factor	: 1.15
		Rated power (based on duty point)	: 16.63 hp
		Max power (non-overloading)	: 17.39 hp
		Motor rating	: 20.00 hp / 14.91 kW (Fixed)
		Panel Max FLA	: 36.8 A
		MCA	: 47.3 A
		MOCP	: 60 A
		*Addition of pilot pump, up-sizing HP, or 575V will affect System FLA, MCA, and MOCP.	

Energy Indexes	
PEI (VL)	: 0.59
ER (VL)	: 41

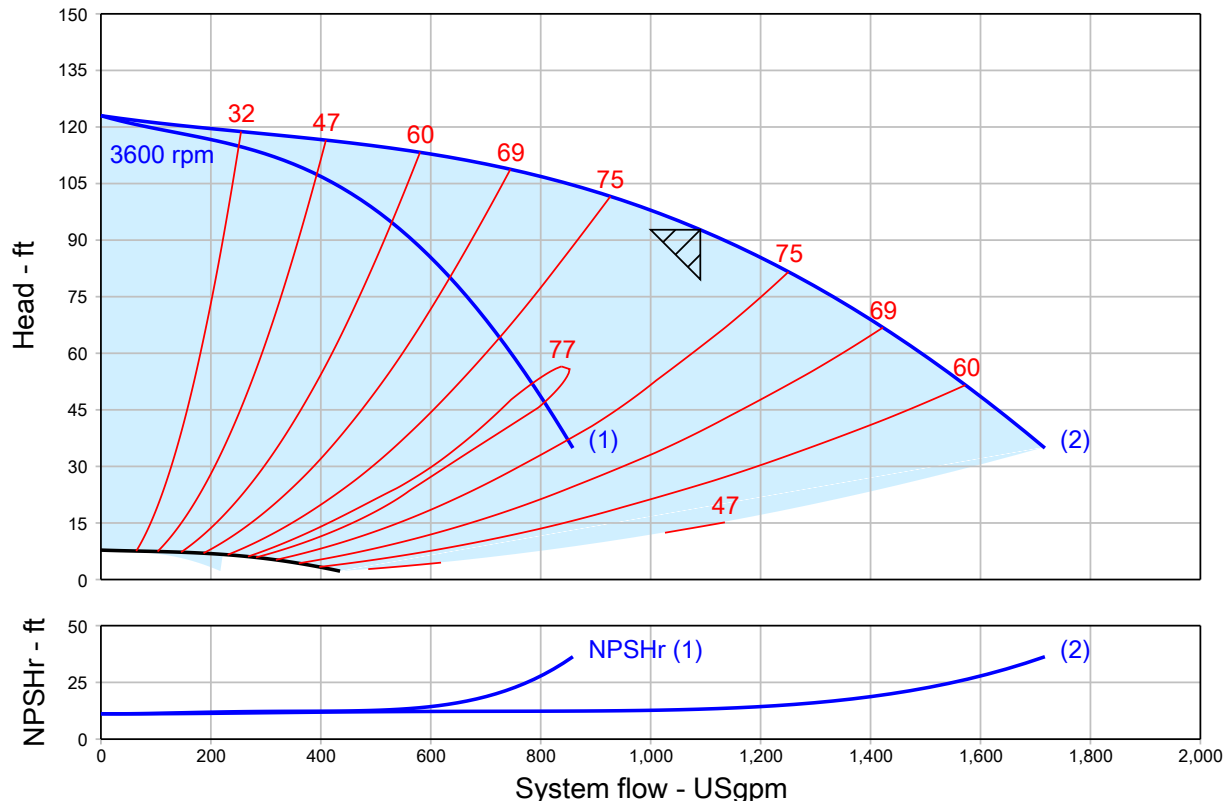

1. Manifolds 8" ANSI Class 150 AISI 316SS Schedule 10s ASTM A312 or $\phi 219.1\text{mm} \times 2\text{mm}$
 2. Base/Frame ASTM A36 Steel
 3. Standard system layout : panel right facing suction
 4. 6" lug style ANSI 150# class butterfly valve
 5. UL Type 3R/12 rated electrical panel
- Note: panel size will vary with options

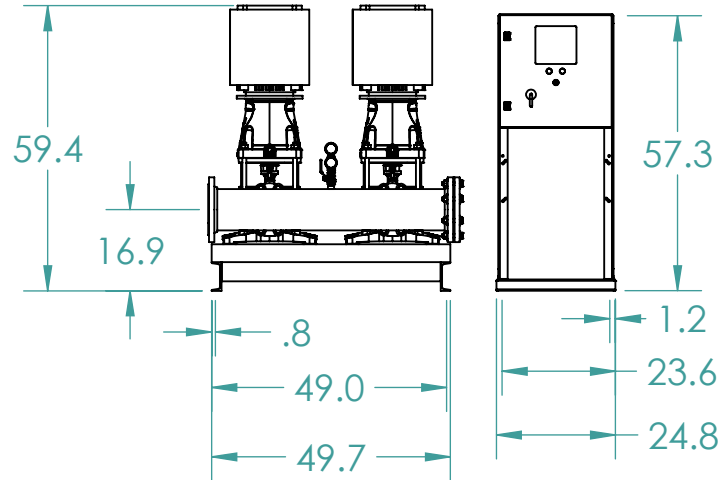
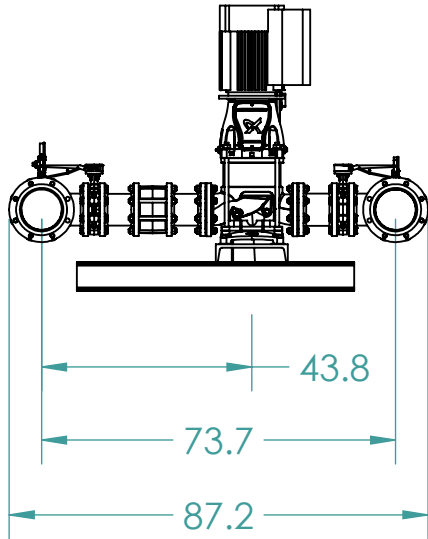
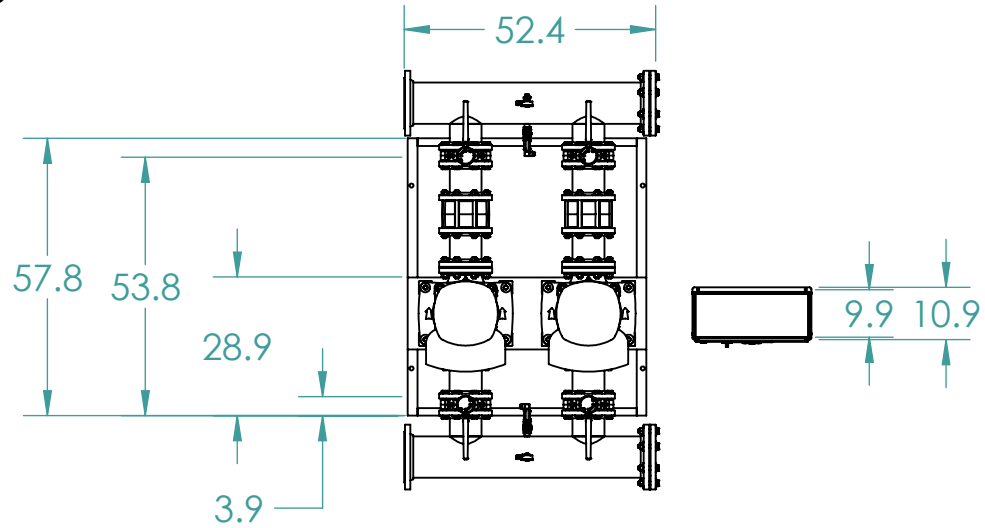
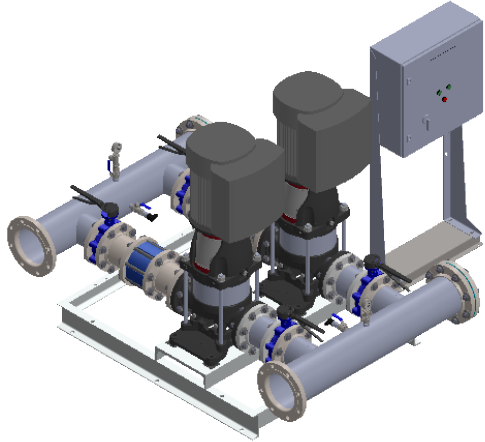

GRUNDFOS 
 FRESNO, CALIFORNIA 93727 USA

Note:
 All dimensions are $\pm 0.5"$
 Not for Construction
 All dimensions subject to
 changewithout notice.

BoosterpaQ Model: HYDRO MPC E 2CRE125-1-1

Power: 3x460 60HZ 2x20HP

Job:

Scale: 1:40

Dwg No:

Rev:

Date:

Drawer

Page:

0

3/23/2020

58847

1 of 1

Grundfos CU 352 Pump Controller

Advanced pump system controller for parallel connected pumps for HVAC and Pressure Boosting Applications



Compatibility

The CU 352 pump controller can control up to six (6) parallel connected pumps in the following manner:

- Direct BUS control: **CRE, CME, VLSE or LCSE** pumps
- Direct BUS control: Pumps with Grundfos **CUE** drives
- Digital/Analog control: Pumps with external drives (requires **IO 351B** Input/Output module)

HVAC Control Modes

- o Constant Differential Pressure control via remote sensor
 - Multi-zone Differential Pressure control up to 6 zones
 - Priority, Minimum or Energy Saving Mode
- o Quadratic, proportional or constant differential pressure control via local sensor
 - Adjustable control curve (Max flow and control head)
 - Efficiency based sequencing automatically updated
- o Constant Flow
- o Constant Temperature
- o Constant Differential Temperature

Pressure Boosting Control Modes

- o Constant Pressure (pump discharge)
- o Quadratic or Proportional discharge pressure
 - Adjustable control curve (Max flow and min. static head)
- o Constant Pressure (remote sensor)

Pump Cascade Control

- o Efficiency based pump sequencing
 - * Updated automatically when setpoint and/or control head are changed
- o Automatic Pump alternation (run hour based)
- o Standby Pumps (single or multiple)
- o Adjustable minimum time between starts / stops
- o Adjustable maximum starts per hour
- o Pump test run (exercise idle pumps)
- o Clock program
- o Proportional Gain and Integral Time adjustment

Application optimized functions:

- o Secondary (Fallback) Sensor
- o Pump curve data (5th or 2nd order polynomial)
 - * Pre-programmed from factory
- o Flow estimation via pump curve data and pressure measurement across pump(s)
- o Reduced operation (generator backup power)
 - Max. kW limit or max. number of pumps
- o Specific energy calculation (kWh per unit volume)
 - *requires flow sensor input
- o Low Flow Stop (Pressure Boosting)
 - Adjustable low flow setting: Energy saver mode, medium flow or high comfort level

Protection and Monitoring

- o Check valve failure detection (MLE motors)
- o Pump outside duty range protection
 - *keeps all operating pumps on their curve
- o Low suction pressure warning and alarm
- o Primary sensor failure reaction setting
- o Soft pressure build-up (Pipe fill mode)
- o Low system pressure warning and alarm
- o High system pressure shutdown
- o Alarm log, last 24, time stamped
- o Data log graph (20 - 3600 samples/hour)
 - (Flow, speed, setpoint, sensor feedback, kW)
- o BMS/EMS communication (see page 4)

Grundfos CU 352 Pump Controller

CU 352 Control user interface

Graphical representation of pump status and speed

Alarm and warning indication

System and individual pump status

On screen help

User defined status, up to 3 parameters, sensor feedback, setpoint, power etc.

Estimated Flow

Screen contrast adjustment

The screenshot shows a control panel with a central display area. At the top, there are tabs for 'Status', 'Operation', 'Alarm', and 'Settings'. The main display shows a pump icon with a speed indicator (78%) and a flow rate (~43gpm). Below this, there's a table for 'Sensor fault (88)' with columns for System, Normal, and CU 352. At the bottom, there's a 'System run' indicator with a green dot and an 'Alarm' indicator with a red dot. A 'GRUNDFOS' logo is at the bottom left, and a 'System run' indicator is at the bottom right. Callouts point to various elements: a question mark icon for help, a pump icon for status, a warning icon for alarms, a flow rate indicator for estimated flow, and a sun icon for contrast adjustment.

Status of inputs and outputs	Alarms and warnings	Startup Wizard
<p>Electrical overview Shows status of inputs along with wiring landing points [in brackets]</p> <p>The screenshot shows two sections: '1.1.1.1 - Analog inputs' and '1.1.1.2 - Digital inputs'. The analog inputs section lists AI1 (CU 352), [51] at 35PSI and AI2 (CU 352), [54] at 35PSI. The digital inputs section lists DI1 (CU 352), [10] as Active, DI2 (CU 352), [12] as Not active, and DI3 (CU 352), [14] as Not active.</p>	<p>Alarm log - Stores last 24 alarms and warnings.</p> <ul style="list-style-type: none"> > Time event occurred > Time event cleared > Alarm code for more detailed description. <p>The screenshot shows a list of alarms with columns for alarm code, description, occurred at, and disappeared at. The first alarm is AI3-CU352 Sensor fault (88) occurring at 08/21/2019 10:12 am. Other alarms include System Water shortage (214) and System Pumps outside duty range (208).</p>	<p>Startup Wizard Step by Step installation guide</p> <ul style="list-style-type: none"> > Set time and date format > Remove air/Prime pumps > Check pump rotation > Set primary sensor <p>The screenshot shows a 'Step-by-step installation guide' for '17/26 - Priming sequence'. It instructs the user to close the valve on the outlet side of all pumps, prime all pumps, and ensure the suction manifold and pipes are primed. It also mentions installing a correctly sized diaphragm tank and checking the precharge pressure.</p>

Grundfos CU 352 Pump Controller

Sequence of operation

Hydronic Circulation

The system controller shall operate equal capacity variable speed pumps to maintain a variable (quadratic or linear) or constant differential pressure. The system controller shall receive an analog signal [4-20mA] from a remote or pump system mounted differential pressure sensor. The controller shall be able to receive a system suction pressure and system discharge pressure to determine the system differential pressure (two independent analog signals). The controller shall have the means to protect pumps against dry running via a user defined low suction pressure setting.

Pressure Boosting

The system controller shall operate equal capacity variable speed pumps to maintain a constant or variable (quadratic or linear) pressure. The system controller shall receive an analog signal [4-20mA] from a remote or pump system mounted pressure sensor. The controller shall be capable of simulating the effect of a remote mounted pressure sensor by quadratically reducing the system discharge pressure setpoint as a function of reduced flow (friction loss compensation).

Cascade Control

Standard Cascade Control (Pumping Efficiency Based):

The pump system controller shall adjust pump speed as necessary to maintain system set-point pressure as flow demand changes. The pump system controller shall start additional pumps upon determination of an increase in efficiency utilizing factory programmed (5th order polynomial) curve data. When the system pressure is equal to the system set-point, all pumps in operation shall reach equal operating speeds. The pump system controller shall have field adjustable Proportional gain and Integral time (PI) settings for system optimization.

Optional Cascade Control (Pump Start Speed Based):

As flow demand increases the pump speed shall be increased to maintain the system set-point pressure. When the operating pump(s) reach the programable start speed, an additional pump will be started and will increase speed until the system set-point is achieved. When the system pressure is equal to the system set-point, all pumps in operation shall reach equal operating speeds. The pump system controller shall have field adjustable Proportional gain and Integral time (PI) settings for system optimization.

Pumps outside duty range (End of curve protection):

When the pumps are outside their allowable operating range, the controller shall switch on an additional pump, distributing a reduced flow through all pumps in operation moving each pump back into its allowable operating region.

Pump Alternation

All pumps in the system shall alternate automatically based on demand, time and fault. If flow demand is continuous with only one pump in operation, the system controller shall have the capability to alternate the pumps every 24 hours, every 48 hours or once per week. The interval and actual time of the pump change-over shall be field adjustable.

Low Flow Stop (Pressure Boosting)

The system controller shall be capable of detecting low flow allowing for pumps to be switched off in an energy saving mode. Upon detection of low flow, the controller shall increase the system setpoint by 5% (adjustable) to store water in a diaphragm or bladder tank and switch off. The pump shall remain off until the system pressure falls 5% below the system setpoint (adjustable). If system flow is still low when the pump switches back on, the pump shall refill the diaphragm tank to 5% above setpoint and switch off again. If system flow increases above the low flow setting, the pump shall return to normal constant pressure mode maintaining the system setpoint.

Grundfos CU 352 Pump Controller

Technical data

Altitude above sea level

Maximum 6,560 feet (2000 m.)

Ambient Temperature

During operation: -4°F to +140°F (-20°C to +60°C)

During transportation: -4°F to +140°F (-20°C to +60°C)

- * At temperatures below 32°F (0°C) the display may react slowly.
- * The display should not be exposed to direct sunlight

Relative air humidity

5 to 95%

Enclosure class

UL type 3R when mounted in the front of a panel with UL type rating 1, 2, 3, 3R, 5, 12, 12K or 13. Overall control panel rating of Type 4/4X available on request.

Supply voltage

1 x 100-240 VAC +/- 10% 50/60Hz, PE
(Class 1 equipment)

Power consumption

Maximum 22 W

Backup battery

The optional backup battery can keep the CU352 powered during intermittent power outages.

The CU 352 will monitor the following:

- short circuit
- wrong polarity
- defective battery
- battery missing
- low battery voltage

Digital inputs (3)

Open-circuit voltage	24 VDC
Closed-circuit current	5 mA, DC
Frequency range	0-4 Hz

Analog inputs (3)

	0-20 mA
Input current and voltage	4-20 mA
	0-10 V
Tolerance	± 3.3 % of full scale
Repetitive accuracy	± 1 % of full scale
Input resistance, current	< 250 Ω
Input resistance, voltage	> 50 kΩ ± 10%
	24 V, 30 mA
Supply to sensor	short-circuit protected

Relay outputs (2)

Normally open contacts	C, NO
Maximum contact load	240 VAC, 2 A
Minimum contact load	5 VDC, 10 mA

Communication protocols

For connection to building management systems, Communication Interface Modules (CIM) can be supplied with the CU 352 controller.

Protocol	CIM Type
LONworks	110
PROFIBUS DP	150
PROFINET IO	500
Modbus RTU	200
Modbus TCP	500
BACnet MS/TP	300
BACnet IP	500
Ethernet IP	500

MLE

Product compatibility

- **Multi-stage:** CRE, CRIE, CRNE, MTRE, MTSE, SPKE, CME
- **Single-stage:** TPE2, TPE3, VLSE, LCSE
- **Systems:** Hydro MPC-E, Hydro Multi-E, Hydro Multi-B, Hydro Solo-E, CMBE home booster.



TM06 5684 2219

MLE is a dedicated motor-drive system for pumps and other applications. Pumps equipped with MLE motors overcome application challenges and save energy in a variety of pump installations in order to reach the lowest Life Cycle Cost (LCC) possible.

Integrated drives

Integrated drives are beneficial because they are installed on non-controlled pumps at no additional installation cost. Once the power supply is connected and the pump is fitted into the pipe system, they are ready to operate at the desired setpoint.

Operating pumps with MLE also reduces CAPEX (capital expense) of additional cabinets, components and facility space by having the entire pump system in line with the pipe system.

MLE is the result of Grundfos' efficient motor technology and it is an efficient IE5 motor, with an efficiency much higher than NEMA Premium, which minimizes OPEX (operating expense).

Robustness throughout the system

The Grundfos full line supply of components, from the power supply to pipe fittings, provides the most robust solutions:

- Built-in protection against power supply disturbances, environment and motor load.
- MLE is designed to mitigate bearing currents.
- No cooling fans in drive (wear part).

MLE product range

1 x 200-240 V	0.33 - 2.0 HP
3 x 200-240 V	1.5 - 7.5 HP
3 x 440-480 V	0.33 - 15 HP*

* Up to 30 HP available with different specifications.

Features and benefits

Feature	Benefit
Application control	
Control modes	Easy commissioning to match system design criteria.
Multipump function including alternating, back-up, or cascade	Neglects the need for external controllers and continuous operation by redundant pump and sensor if either component fails.
Differential pressure or temperature with 2 sensors	Lower CAPEX by common inexpensive sensor types.
Pump curve adjustments and run at power limit	Stabilizes unstable pump curves and extends operating range.
Setpoint influence	Adapts QH to internal or measured values.
Energy saving for lower OPEX	
AUTOADAPT or FLOWLIMIT	Continuously adapts to the most efficient curve and reduces pressure loss in the system.
Low-flow stop function	Improved energy optimization and comfort.
ECM motor that exceeds the NEMA Premium efficiency levels	ECM motors have significantly lower motor loss than NEMA Premium motors. This alone reduces energy consumption by 10 % with a typical pump load profile.
Condition monitoring	
Limit Exceed function	Any value can be supervised to protect the system.
Loss of prime and dry run	Protects the shaft seal.
Cavitation protection	Protects the impellers.
Flow estimate and heat energy monitor	Monitoring of the heating system's performance.
Overload and temperature	Protects the frequency converter and motor.
Stop at minimum speed	Protects the pump and saves energy.
Motor bearings monitors	Ensures uptime by preventive maintenance.
Robustness	
Operating temperature between -4 and +140 °F	Allows installation almost anywhere and high margins in control rooms, resulting in longer product service life.
Impulse transient resistance (VDE0160 compliant)	Resistance against lightning, ESD, switching impulses and utility fault clearing.
Interruptions and voltage sags (SEMIF47 compliant)	Keeps process running and derates the pump to the available power.
Line harmonics resistance (EN 61000-4-13, class 3)	Built-in compensation of disturbance to avoid overheating of motor windings and maintaining a steady pump operation.
Built-in RFI filters	Neglects the need for external components.
NEMA3 / NEMA4 enclosures	Installed in-line to pipe systems at no added cost.

Grundfos iSOLUTIONS

Grundfos iSOLUTIONS delivers the optimal combination of pumps, drives and auxiliary components for the specific application, incorporating special features and functions, and building on application knowledge and experience.

Grundfos iSOLUTIONS allows easy integration of pumps, drives, measurements, controls, protections, and communication, saving you valuable engineering, installation and commissioning time.

To learn more, visit: www.grundfos.com/isolutions

Sensors

MLE is sensor-independent and controls the pump to any measured feedback.

Grundfos offers several sensors to be used in pump solutions:

- pressure sensors
- temperature sensors
- differential pressure sensors
- differential temperature sensors
- flow meters.

Grundfos GO Remote

Grundfos GO Remote for iOS and Android ensures easy and quick commissioning, monitoring and servicing of pumps with MLE motors.



TW07 4786 2419

Technical specifications

Motor data			
	Operating range (rpm)	Constant power (rpm)	Constant torque (rpm)
Speed range	180-2000	1740-2000	900-1740
	360-4000	3480-4000	1750-3480
	360-4000	3400-4000	2000-3400
	500-5900	4000-5900	-
Voltage tolerances	± 10 %		
Frequency	50-60 Hz ± 5 %		
Network	TN/TT (optional: IT) according to IEC 60364		
Environmental limits			
Degree of protection	NEMA3 / NEMA4		
Operating temp.	-4 to +140 °F derating above 122 °F		
Storage temp.	-4 to +140 °F		
Altitude	0-3280 ft without derating / 0-11480 ft with derating		
Humidity	0-95 %, non-condensing		
Inputs/outputs	FM100	FM200	FM300
Digital inputs	1	1	2
Digital inputs/ outputs	1	1	2
Relay outputs	-	2	2
Analog inputs	1 (only V)		
Pt100/Pt1000 inputs	-	-	2
+5 V supply	Y	Y	Y
+24 V supply	-	Y	Y
Grundfos Digital Sensor input	-	Y	Y
LiqTec sensor input	-	-	Y
Digital inputs (dedicated)	0-5 V		
Digital inputs/ outputs	0-24 V, resistive or inductive		
Analog input	0-20 mA / 4-20 mA, 0.5 - 3.5 V / 0-5 V / 0-10 V		
Relay output	250 V AC/30 V DC, max. continuous current 2 A rms		
Connectivity			
Wireless (radio)	Yes, GENlair		
RS-485	Yes, GENlair		
Communication options	• LONWorks (CIM 100)		
	• PROFIBUS DP (CIM 150)		
	• Modbus RTU (CIM 200)		
	• GSM/GPRS (CIM 250)		
	• 3G/4G cellular (CIM 260)		
	• GiC/GRM 3G/4G (CIM 280)		
	• BACnet MS/TP (CIM 300) PROFINET IO (CIM 500)		
	• Modbus TCP (CIM 500)		
	• BACnet IP (CIM 500)		
	• Ethernet IP (CIM 500)		
Compliance			
Conformity to standards	CE, EAC, RCM, CCC, and cURus (UL)		
Harmonics	IEC/EN 61000-3-12		
EMC	Up to 10.0 HP (7.5 HP low speed): Category C1 according to EN 61800-3, corresponding to CISPR 11, class B (residential area)		
	Above 10.0 HP (7.5 HP low speed): Category C3 according to EN 61800-3, corresponding to CISPR 11, class A, group 2 (industrial area)		

99689406 0719

ECM: 1264915

Vibration Isolation

Common vibration concerns with frame mounted end suction pumps

- Misalignment between motor shaft and pump shaft is the #1 source of pump vibration
 - o End suction pumps typically have large over-hung impellers with high rotating inertia, that when misaligned creates large unbalanced forces and results in vibration
 - o Offset discharge throat of the volute creates the radial load
 - o Decreased component life
- End suction pump bearing loading is primarily from radial forces



Unbalanced forces and increased vibration

Grundfos CR Multistage pump benefits:

- Register fit between motor and pump
- No alignment required for lifetime of operation
- Minimized vibration
- Longer component life
- Quiet operation (product lubricated pump bearings)
- CR Multistage pumps offer the lowest rotating inertia compared to most other pumps in same duty conditions
- Low rotating inertia equals less opportunity for vibration
- Multistage pump bearing loading is on average 10% radial and 90% axial forces



No alignment is required

Pump systems with Grundfos CR(E) Multistage pumps

- Vibration Isolation:
 - o 1/2" thick dampeners at pump base mounting points (4 per pump)
 - o Inertia bases and grouting are not required when mounted to concrete housekeeping pad
 - o Flexible connectors on manifold connections are recommended

