

SEG

2.0 to 5.5 hp
ANSI, 60 Hz



1. Introduction	3	12. Accessories	35
Introduction	3	Installation systems for SEG pumps	35
Applications	3	Other accessories	35
Construction features	3	SEG pumps	36
		Level controllers	36
2. Identification	4	13. Grundfos Product Center	38
Type key	4	Grundfos GO	39
Nameplate	4		
3. Selection of product	5		
Ordering a pump	5		
4. Performance range	6		
Performance overview	6		
5. Product range	8		
Product range	8		
6. Variants	10		
List of variants	10		
7. Construction	11		
Material specification, SEG pumps	11		
8. Product description	16		
Features	16		
Operating conditions	17		
Motor range	17		
Variable frequency drive operation	17		
Approvals	18		
Wiring diagrams	18		
9. Curve charts	19		
How to read the performance curves	19		
Curve conditions	20		
Performance tests	20		
Certificates	20		
Witness test	20		
10. Performance curves and technical data	21		
SEG.A15.20.(EX).2.1.603	21		
SEG.A15.20.R2.(EX).2.1.603	22		
SEG.A15.20.R1.(EX).2.1.603	23		
SEG.A15.20.(EX).2.60H/L/M	24		
SEG.A15.20.R2.(EX).2.60H/M	25		
SEG.A15.20.R1.(EX).2.60H/M	26		
SEG.A15.30.(EX).2.60H/L/M	27		
SEG.A15.40.(EX).2.60H/L/M	28		
SEG.A15.55.(EX).2.60H/L/M	29		
SEG.A20.30.(EX).2.60H/L/M	30		
SEG.A20.40.(EX).2.60H/L/M	31		
SEG.A20.55.(EX).2.60H/L/M	32		
11. Dimensions and weights	33		
Auto-coupling installation	33		
Free-standing installation	34		
Weights	34		

1. Introduction

Introduction

This data booklet describes the Grundfos SEG sewage grinder pumps.



TM06 6020 0416

Fig. 1 SEG pumps

The SEG pumps are designed with a grinder system which grinds solids into small pieces so that they can be led away through outlet pipes of a relatively small diameter.

The pumps are made of wear-resistant materials, such as cast iron and stainless steel. These materials ensure reliable operation.

The pumps are available with motors of 2.0 hp and up to 5.5 hp. All motors are 2-pole motors.

The nominal diameter of the pump outlet port is 1.5" (40 mm) or 2.0" (50 mm).

The pumps are available for these installation types:

- submerged installation on auto-coupling systems
- submerged installation, free-standing.

Applications

The SEG pumps are ideal for use where gravity sewage systems are not available. Examples include small towns, farm areas, and areas with difficult topography, such as rocky terrains with large differences in levels, or any other area where a pressurized system offers advantages.

Construction features

All pumps have the following features:

- cable connection to motor via cable plug
- watertight cable entry of corrosion-resistant stainless steel with polyamide
- stainless steel clamp connection between motor and pump
- cartridge shaft seal
- heavy-duty bearings greased for life
- patented grinder system ensuring extremely high efficiency and reliable operation
- patented SmartTrim system enabling quick and easy impeller clearance adjustment in order to maintain peak performance
- thermal switches built into the motor windings providing protection against overheating
- FM-approved motors for potentially explosive environments
- moisture switches built into the motor.

2. Identification

Type key

The type key covers the entire range of Grundfos SEG sewage grinder pumps. Each SEG pump can be identified by means of the type key.

Example: SEG.A15.20.R2.2.1.6.03

Code	Explanation	Designation
SE	Grundfos sewage pumps	Pump type
G	Grinder system in the pump inlet	Impeller type
A15	Nominal diameter of the outlet port / 10 [inch] 1.5" (40 mm)	Pump outlet
A20	Nominal diameter of the outlet port / 10 [inch] 2.0" (50 mm)	
20	Code number from type designation / 10 [hp]	Output power, P2
[]	Standard pump	
R1	Reduced impeller [1.6 hp (1.2 kW)]	Equipment in pump
R2	Reduced impeller [1.2 hp (0.9 kW)]	
[]	Non-explosion-proof, CSA-approved pump	Pump version
Ex	Explosion-proof, CSA- and FM-approved pump	
2	2-pole	Number of poles
1	Single-phase motor	Number of phases
[]	Three-phase motor	
6	60 Hz	Frequency
03	208-230 V	Voltage
0H	460 V	
0L	575 V	
0M	200-230 V	
[]	Standard material (EN-GJL-200)	Pump material
Z	Custom-built pump	Customization

Nameplate

The nameplate states the operating data and approvals applying to the pump.

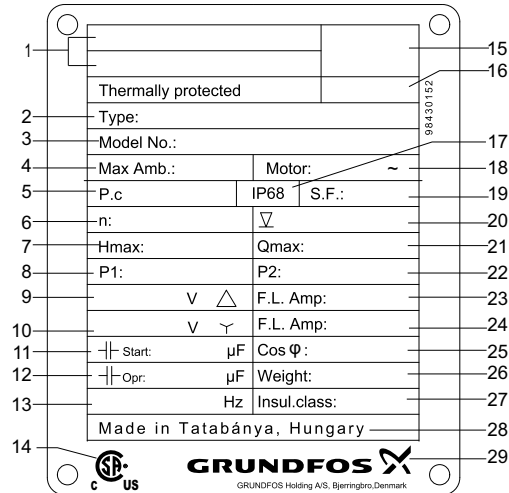

Fig. 2 SEG nameplate

Pos.	Description
1	FM description
2	Type designation
3	Product number + serial number
4	Maximum liquid temperature
5	Production code, year and week
6	Speed [rpm]
7	Maximum head [ft]
8	Rated input power [hp]
9	Combined voltage expression 1
10	Combined voltage expression 2
11	Starting capacitor [μF]
12	Run capacitor [μF]
13	Frequency [Hz]
14	Electrical safety*
15	Approval
16	Mark for continuously operated motor
17	Enclosure class
18	Phases
19	Service factor
20	Maximum installation depth [ft]
21	Maximum flow rate [gpm]
22	Rated power output [hp]
23	Combined ampere expression 1
24	Combined ampere expression 2
25	Cos φ, 1/1 load
26	Net weight [lb]
27	Insulation class/temperature rise
28	Production country
29	Grundfos logo

* For USA and Canada.

TM06 5866 0216

3. Selection of product

Ordering a pump

When ordering a pump, take the following aspects into consideration:

- pump type
- custom-built variation (option)
- accessories
- controller
- explosion-proof version.

Pump type

When you have selected the pump type, you can identify the specific pump that best meets your needs in [Product range](#) on page 8, and [Type key](#) on page 4.

The list below is a detailed description of the product you get if you order the following pump:

Pump	Product number
SEG.A15.20.2.1.603	98280867

- Pump as specified in the type key.
- 33 feet (10 m) of cable.
- Paint: NSC 9000 N/RAL 9005 (black), gloss code 30 ± 10 (according to ISO 2813), thickness of minimum 100 µm and maximum 200 µm.
- Thermal switches built into the motor windings.
- Tested according to ANSI-HI centrifugal pump test 11.6:2012 3B.

See [Performance curves and technical data](#) on page 21, for selection of a pump.

Note: Pump-specific data can also be found in Grundfos Product Center at www.grundfos.com by entering the product number 98280867.

For further information on Grundfos Product Center, see page 38.

Custom-built variants

The pumps can be customized to meet individual requirements. Many pump features and options are available for customization, such as explosion-proof versions and cable lengths.

Accessories

Depending on installation type and pump variant, accessories may be required.

See [Accessories](#) on page 35, for selection of the correct accessories.

Note: Ordered accessories are not fitted from factory.

Controller

The following controllers are available:

SEG

- Dedicated Controls, DC. See page 36.
- SLC for simplex installation. See page 36.
- DLC for duplex installation. See page 36.

SEG approvals

The standard versions of SEG 60 Hz pumps have been approved by CSA, and the explosion-proof versions hold a CSA and FM type examination certificate.

4. Performance range

Performance overview

Figures 3 and 4 show the performance range of SEG pumps. They give an overview of the various sizes.

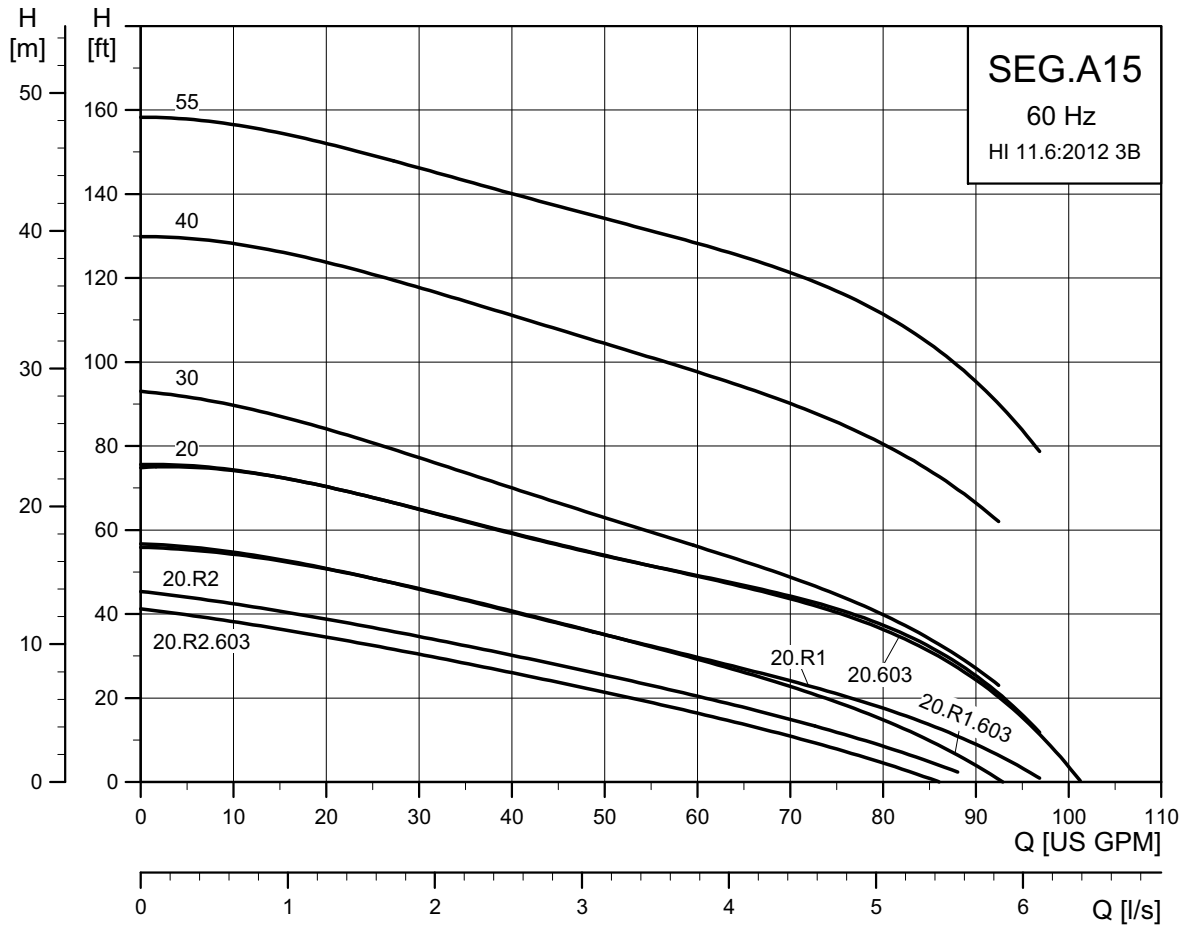

TM05 8136 4715

Fig. 3 Performance range of pumps with A15 [ANSI 1.5" (DN 40)] outlet flange

Channel-impeller pumps	Curve number
SEG.A15.20.(EX).2.1.603	20.603
SEG.A15.20.R2.(EX).2.1.603	20.R2.603
SEG.A15.20.R1.(EX).2.1.603	20.R1.603
SEG.A15.20.(EX).2.60H/M	20
SEG.A15.20.R2.(EX).2.60H/M	20.R2
SEG.A15.20.R1.(EX).2.60H/M	20.R1
SEG.A15.30.(EX).2.60H/M	30
SEG.A15.40.(EX).2.60H/M	40
SEG.A15.55.(EX).2.60H/M	50

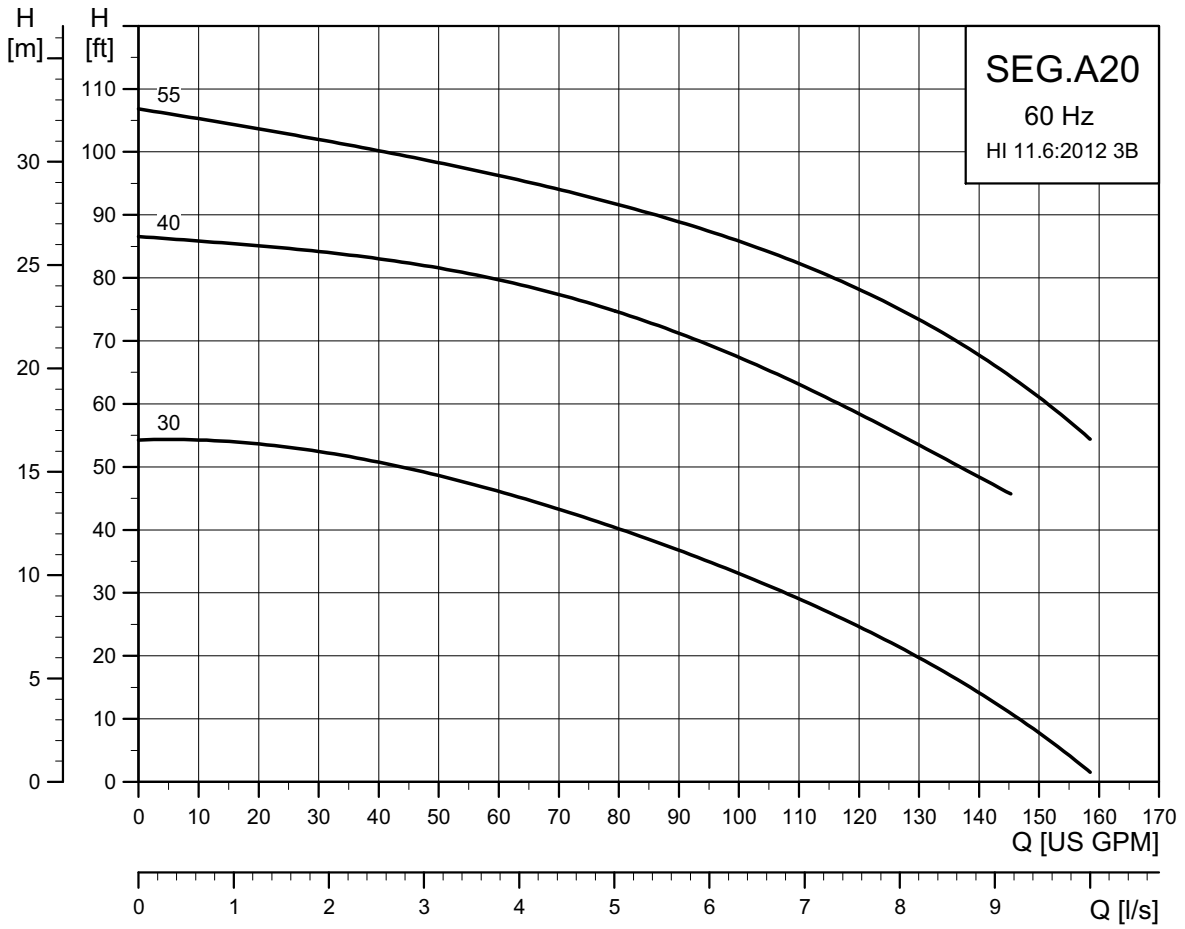

TM05 8137 4715

Fig. 4 Performance range of pumps with A20 [ANSI 2.0" (DN 50)] outlet flange

Channel-impeller pumps	Curve number
SEG.A20.30.(EX)2.60H/M	30
SEG.A20.40.(EX)2.60H/M	40
SEG.A20.55.(EX)2.60H/M	55

5. Product range

Product range

SEG pumps with A15 outlet flange

Pump type	Supply voltage [V]	Starting method	Cable length [ft (m)]	Thermal protection	Product number
SEG.A15.20.2.1.603	1 x 208-230	DOL	33 (10)	Thermal switch	98280867
SEG.A15.20.R2.2.1.603	1 x 208-230	DOL	33 (10)	Thermal switch	98682338
SEG.A15.20.R1.2.1.603	1 x 208-230	DOL	33 (10)	Thermal switch	98682359
SEG.A15.20.2.60H	3 x 460	DOL	33 (10)	Thermal switch	98280869
SEG.A15.20.R2.2.60H	3 x 460	DOL	33 (10)	Thermal switch	98682339
SEG.A15.20.R1.2.60H	3 x 460	DOL	33 (10)	Thermal switch	98682386
SEG.A15.20.2.60L	3 x 575	DOL	33 (10)	Thermal switch	98280895
SEG.A15.20.2.60M	3 x 200-230	DOL	33 (10)	Thermal switch	98280851
SEG.A15.20.R2.2.60M	3 x 200-230	DOL	33 (10)	Thermal switch	98682355
SEG.A15.20.R1.2.60M	3 x 200-230	DOL	33 (10)	Thermal switch	98682389
SEG.A15.30.2.60H	3 x 460	DOL	33 (10)	Thermal switch	98280872
SEG.A15.30.2.60L	3 x 575	DOL	33 (10)	Thermal switch	98280898
SEG.A15.30.2.60M	3 x 200-230	DOL	33 (10)	Thermal switch	98280853
SEG.A15.40.2.60H	3 x 460	DOL	33 (10)	Thermal switch	98280877
SEG.A15.40.2.60L	3 x 575	DOL	33 (10)	Thermal switch	98280921
SEG.A15.40.2.60M	3 x 200-230	DOL	33 (10)	Thermal switch	98280855
SEG.A15.55.2.60H	3 x 460	DOL	33 (10)	Thermal switch	98280875
SEG.A15.55.2.60L	3 x 575	DOL	33 (10)	Thermal switch	98280925
SEG.A15.55.2.60M	3 x 200-230	DOL	33 (10)	Thermal switch	98280858

SEG explosion-proof pumps with A15 outlet flange

Pump type	Supply voltage [V]	Starting method	Cable length [ft (m)]	Thermal protection	Product number
SEG.A15.20.EX.2.1.603	1 x 230	DOL	33 (10)	Thermal switch	98280868
SEG.A15.20.R2.EX.2.1.603	1 x 208-230	DOL	33 (10)	Thermal switch	98682391
SEG.A15.20.R1.EX.2.1.603	1 x 208-230	DOL	33 (10)	Thermal switch	98682395
SEG.A15.20.EX.2.60H	3 x 460	DOL	33 (10)	Thermal switch	98280871
SEG.A15.20.R2.EX.2.60H	3 x 460	DOL	33 (10)	Thermal switch	98682392
SEG.A15.20.R1.EX.2.60H	3 x 460	DOL	33 (10)	Thermal switch	98682396
SEG.A15.20.EX.2.60L	3 x 575	DOL	33 (10)	Thermal switch	98280896
SEG.A15.20.EX.2.60M	3 x 200-230	DOL	33 (10)	Thermal switch	98280852
SEG.A15.20.R2.EX.2.60M	3 x 200-230	DOL	33 (10)	Thermal switch	98682394
SEG.A15.20.R1.EX.2.60M	3 x 200-230	DOL	33 (10)	Thermal switch	98682397
SEG.A15.30.EX.2.60H	3 x 460	DOL	33 (10)	Thermal switch	98280873
SEG.A15.30.EX.2.60L	3 x 575	DOL	33 (10)	Thermal switch	98280899
SEG.A15.30.EX.2.60M	3 x 200-230	DOL	33 (10)	Thermal switch	98280854
SEG.A15.40.EX.2.60H	3 x 460	DOL	33 (10)	Thermal switch	98280878
SEG.A15.40.EX.2.60L	3 x 575	DOL	33 (10)	Thermal switch	98280923
SEG.A15.40.EX.2.60M	3 x 200-230	DOL	33 (10)	Thermal switch	98280856
SEG.A15.55.EX.2.60H	3 x 460	DOL	33 (10)	Thermal switch	98280876
SEG.A15.55.EX.2.60L	3 x 575	DOL	33 (10)	Thermal switch	98280927
SEG.A15.55.EX.2.60M	3 x 200-230	DOL	33 (10)	Thermal switch	98280860

For accessories, see [Accessories](#) on page 35.

SEG pumps with A20 outlet flange

Pump type	Supply voltage [V]	Starting method	Cable length [ft (m)]	Thermal protection	Product number
SEG.A20.30.2.60H	3 x 460	DOL	33 (10)	Thermal switch	98280879
SEG.A20.30.2.60L	3 x 575	DOL	33 (10)	Thermal switch	98280928
SEG.A20.30.2.60M	3 x 200-230	DOL	33 (10)	Thermal switch	98280861
SEG.A20.40.2.60H	3 x 460	DOL	33 (10)	Thermal switch	98280891
SEG.A20.40.2.60L	3 x 575	DOL	33 (10)	Thermal switch	98280941
SEG.A20.40.2.60M	3 x 200-230	DOL	33 (10)	Thermal switch	98280863
SEG.A20.55.2.60H	3 x 460	DOL	33 (10)	Thermal switch	98280893
SEG.A20.55.2.60L	3 x 575	DOL	33 (10)	Thermal switch	98280943
SEG.A20.55.2.60M	3 x 200-230	DOL	33 (10)	Thermal switch	98280865

For accessories, see [Accessories](#) on page 35.

SEG explosion proof pumps with A20 outlet flange

Pump type	Supply voltage [V]	Starting method	Cable length [ft (m)]	Thermal protection	Product number
SEG.A20.30.EX.2.60H	3 x 460	DOL	33 (10)	Thermal switch	98280880
SEG.A20.30.EX.2.60L	3 x 575	DOL	33 (10)	Thermal switch	98280930
SEG.A20.30.EX.2.60M	3 x 200-230	DOL	33 (10)	Thermal switch	98280862
SEG.A20.40.EX.2.60H	3 x 460	DOL	33 (10)	Thermal switch	98280892
SEG.A20.40.EX.2.60L	3 x 575	DOL	33 (10)	Thermal switch	98280942
SEG.A20.40.EX.2.60M	3 x 200-230	DOL	33 (10)	Thermal switch	98280864
SEG.A20.55.EX.2.60H	3 x 460	DOL	33 (10)	Thermal switch	98280894
SEG.A20.55.EX.2.60L	3 x 575	DOL	33 (10)	Thermal switch	98280944
SEG.A20.55.EX.2.60M	3 x 200-230	DOL	33 (10)	Thermal switch	98280866

For accessories, see [Accessories](#) on page 35.

6. Variants

List of variants

Motor		
Standard cables	Cable B, 7G AWG16.	50 ft (15 m)
		65 ft (20 m)
		80 ft (25 m)
		100 ft (30 m)
		130 ft (40 m)
		165 ft (50 m)
Ex cables	Cable B, 7B AWG16 Ex.	50 ft (15 m)
		65 ft (20 m)
		80 ft (25 m)
		100 ft (30 m)
		130 ft (40 m)
Screened power cables for variable frequency drives	Screened cable B.	165 ft (50 m)
		33 ft (10 m)
		50 ft (15 m)
		65 ft (20 m)
		80 ft (25 m)
		100 ft (30 m)
		130 ft (40 m)
Cable protection	For 7-core cable.	
Special motor	Contact Grundfos.	

Tests

Test at specified duty on standard impeller curve	Contact Grundfos.	
Trimmed impeller for specified duty test	Contact Grundfos.	
Additional test of entire QH curve (including report)	5 to 10 flows from pump performance curve.	Contact Grundfos.
Different test standard	Efficiency guaranteed by Grundfos.	ISO 9906:2012 grade 2B/2U or 1B.
Witness test	Contact Grundfos.	

Note: Order customized duty point or other grades with 5-point test certificate together with the pump.

Certificates

CSA-approved pump report	Special Grundfos report. Contact Grundfos.	
Certificate of compliance with order	According to EN 10204 2.1.	According to ANSI HI 11.6:2012.
Pump certificate	According to EN 10204 2.2.	According to ANSI HI 11.6:2012.
Inspection certificate	According to EN 10204 3.1.	According to ANSI HI 11.6:2012.
Material specification report	According to EN 10204 3.1B.	
Material report with certificate	According to EN 10204 3.2.	Material supplier information.
Inspection certificate, Lloyds Register	According to EN 10204 3.2.	
Inspection certificate, DNV (Det Norske Veritas)	According to EN 10204 3.2.	
Inspection certificate, Germanischer Lloyd	According to EN 10204 3.2.	
Inspection certificate, American Bureau of Shipping	According to EN 10204 3.2.	
Inspection certificate, Bureau Veritas	According to EN 10204 3.2.	
Registro Italiano Navale Argenteure	According to EN 10204 3.2.	
Other third-party test certificate	Contact Grundfos.	

Miscellaneous

Special packaging	Contact Grundfos.	
Special nameplate	Contact Grundfos.	
Other variants	Contact Grundfos.	
Chemical-resistant shaft seal	FKM, standard (NBR).	
Chemical-resistant pump	FKM, standard (NBR).	
Internal surface treatment	Ceramic coating (impeller and pump housing).	
	Extra epoxy (CED) coating.	
Top coating	Black (RAL 9005).	
	Other color.	

7. Construction

Material specification, SEG pumps

The position numbers in the table below refer to the sectional drawings and exploded views on the following pages.

Pos.	Description	Material	AISI/ASTM	EN standard
6a	Pin	Stainless steel	301	1.4310
7a	Rivet	Stainless steel	A2/304	1.4301
9a	Key	Stainless steel	-	-
26a	O-ring	NBR	-	-
37	O-ring	NBR	-	-
37a	O-rings	NBR	-	-
44	Grinder ring	Stainless steel	630	1.4542
45	Grinder head	Stainless steel	630	1.4542
48	Stator	-	-	-
48a	Terminal board	-	-	-
49	Impeller	Cast iron	A48 30B	EN-GJL-200
50	Pump housing	Cast iron	A48 30B	EN-GJL-200
55	Stator housing	Cast iron	A48 30B	EN-GJL-200
58	Shaft seal retainer	Cast iron	A48 30B	EN-GJL-200
66	Locking ring	Stainless steel	-	-
68	Adjusting nut	Stainless steel	431	1.4057
76	Nameplate	Stainless steel	304	1.4301
92	Clamp	Stainless steel	304	1.4301
102	O-ring	NBR	-	-
103	Bush	Stainless steel	431	1.4057
104	Seal ring	NBR	-	-
105/105a	Shaft seal	Primary seal [2.0 hp (1.5 kW)]: SiC/SiC	-	-
		Secondary seal [2.0 hp (1.5 kW)]: lip seal, NBR		
		Primary seal [3.0 to 5.5 hp (2.6 to 4.0 kW)]: SiC/SiC		
		Secondary seal [3.0 to 5.5 hp (2.6 to 4.0 kW)]: carbon/aluminium oxide		
		Other components: NBR, stainless steel		
107	O-rings	NBR	-	-
112a	Locking ring	Stainless steel	-	-
150a	Stator in housing, complete	-	-	-
153	Bearing, lower	2.0 hp (1.5 kW): 6303 3.0 to 5.5 hp (2.6 to 4.0 kW): 3205	-	-
153a	Lock washer	Stainless steel	-	-
153b	Locking ring	Stainless steel	-	-
154	Bearing, top	2.0 hp (1.5 kW): 6201 3.0 to 5.5 hp (2.6 to 4.0 kW): 6205	-	-
155	Oil chamber	Cast iron	A48 30B	EN-GJL-200
158	Corrugated spring	Steel	-	-
159	O-ring	NBR	-	-
172	Rotor/shaft	Shaft part at rotor: steel Shaft end at hydraulics: stainless steel	304	1.0533 1.4301
173	Screw	Steel	-	ISO 7045 Grade 4.8
173a	Washer	Steel	-	DIN 6798 A
176	Inner plug part	PET	-	-
181	Outer plug part	CR rubber, cable H07RN-F	CF-8	1.4308
188a	Screw	Stainless steel	304	1.4301
190	Lifting bracket	Stainless steel	CF-8	1.4308
193	Oil screw	Stainless steel	304	A2-70
193a	Oil	Shell Ondina X420	-	-
194	Gasket	Nylon	-	-
195	Lock washer	Stainless steel	-	-
198	O-ring	NBR	-	-
199	O-ring	NBR	-	-
	Paint	Two-component epoxy	-	-

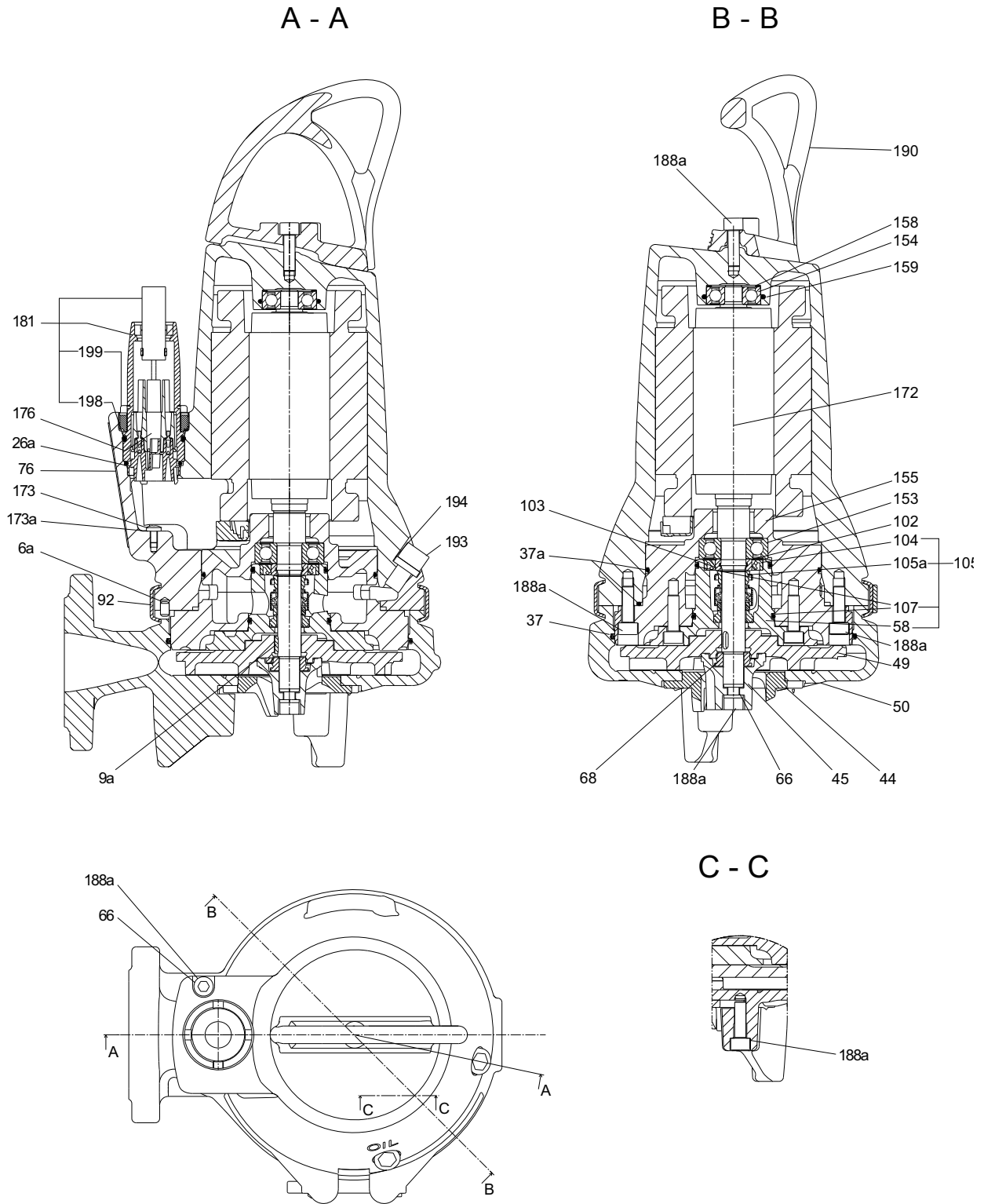

Fig. 5 Sectional drawing of SEG pumps, 2.0 hp (1.5 kW)

TM06 6108 4717

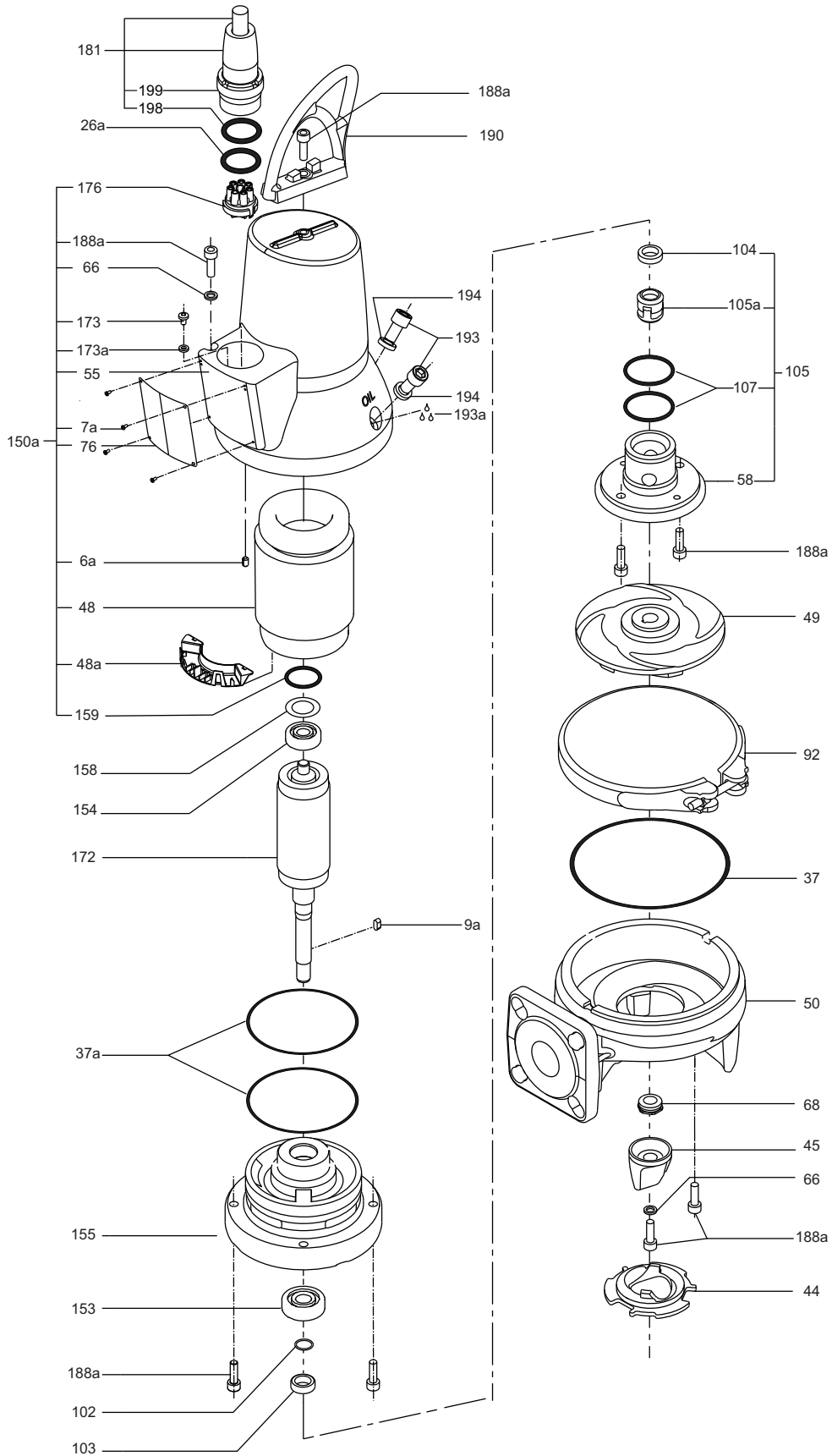

Fig. 6 Exploded view of SEG pumps, 2.0 hp (1.5 kW)

TM06 5739 4717

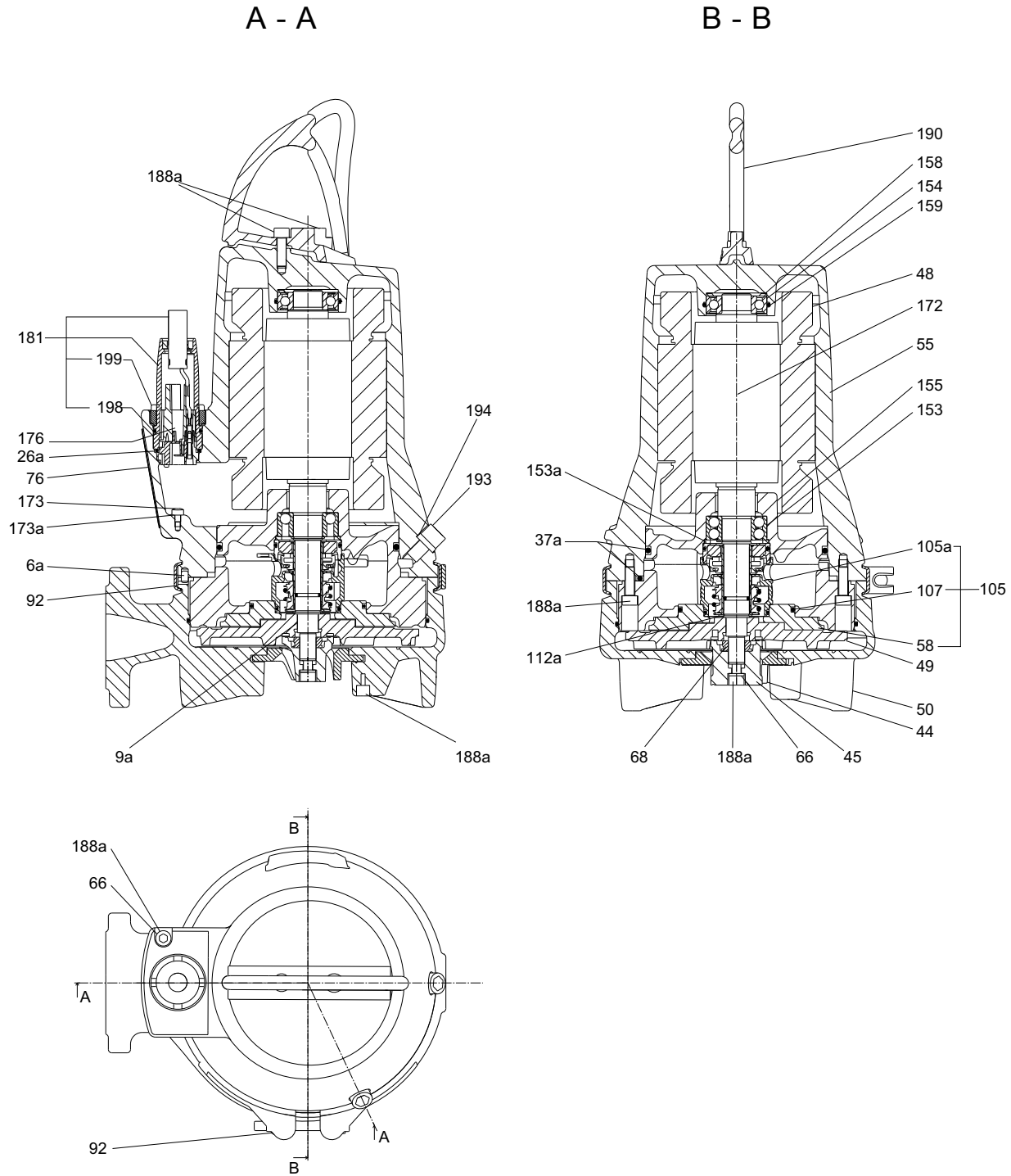

Fig. 7 Sectional drawing of SEG pumps, 3.0 to 5.5 hp (2.6, 3.1 and 4.0 kW)

TM06 6110 4717

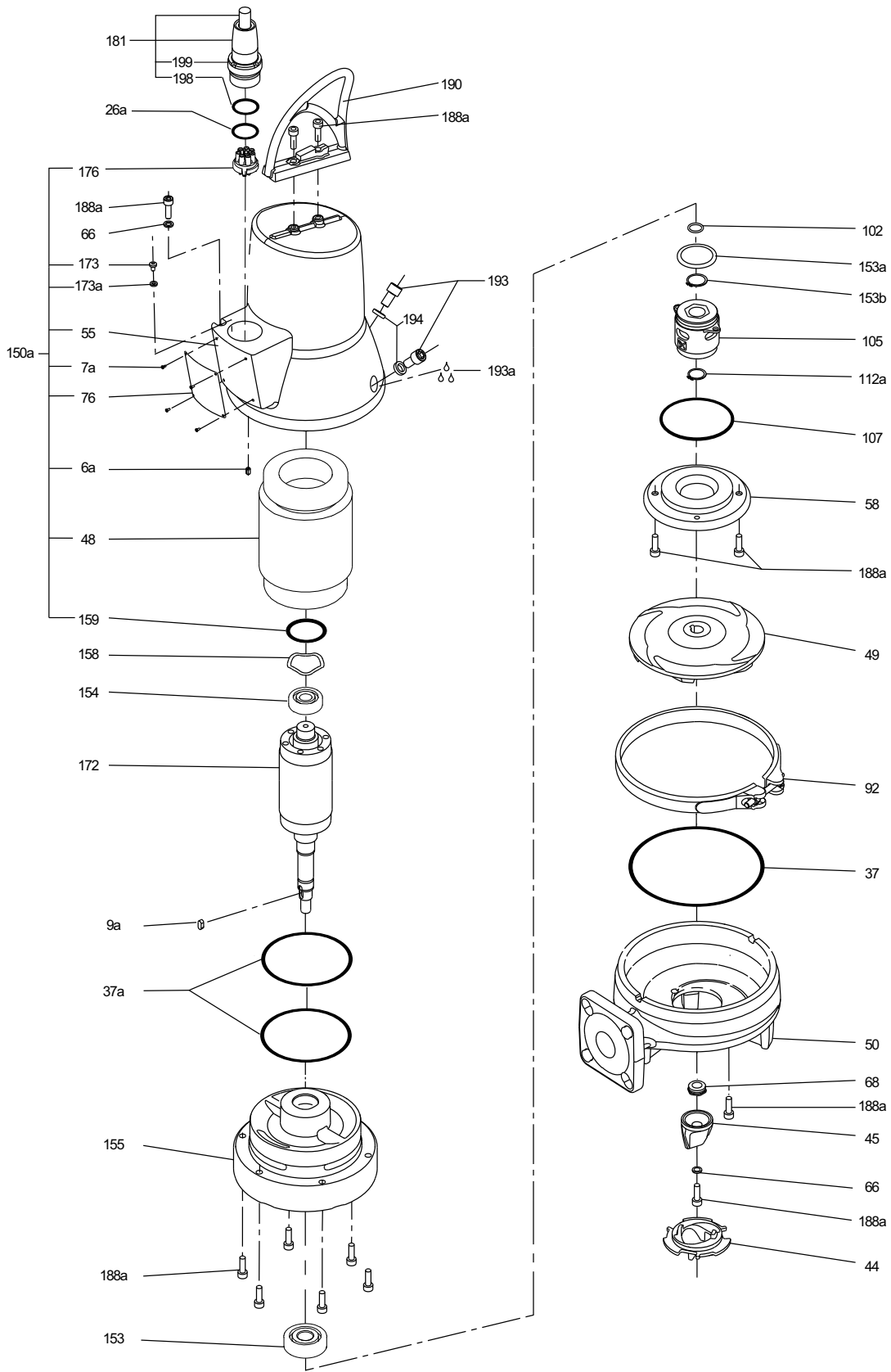

Fig. 8 Exploded view of SEG pumps, 3.0 to 5.5 hp (2.6, 3.1 and 4.0 kW)

TM06 5759 4717

8. Product description

Features

Ball bearings

The ball bearings are greased for life.

Top bearings:

- 2.0 hp (1.5 kW):
Single-row ball bearing 6201.
- 3.0 hp (2.6 kW) and up:
Single-row ball bearing 6205.

Bottom bearings:

- 2.0 hp (1.5 kW):
Single-row ball bearing 6303.
- 3.0 hp (2.6 kW) and up:
Angular-contact ball bearing 3205.

Shaft seal

The SEG range is available with two shaft seal variants. Both variants are fitted as cartridge seals. The shaft seal separates the motor from the pumped liquid.

Pumps of 2.0 hp (1.5 kW) have a silicon carbide/silicon carbide (SiC/SiC) mechanical shaft seal as primary seal and a lip seal as secondary seal. In connection with service, the mechanical shaft seal and the lip seal are supplied as one unit ready for fitting.

Pumps of 3.0 hp (2.6 kW) and up have a double mechanical seal with a cartridge consisting of a silicon carbide/silicon carbide (SiC/SiC) mechanical shaft seal as primary seal and a carbon/aluminium oxide mechanical shaft seal as secondary seal.

Motor

The motor is a watertight, totally encapsulated motor.

Insulation class: F (311 °F (155 °C)).

Supply voltage tolerance: - 10 %/+ 6 %.

Temperature class: F (221 °F (105 °C)).

Enclosure class: IP68.

Maximum starts per hour: 30.

For motor protection and sensors, see [Sensors](#) on page 16.

Power supply cables

Standard cable

Cable type	Outer cable diameter [inch (mm)]	Bending radius	
		Fixed	Free
7G AWG16	0.61 ± 0.02 (15.5 ± 0.5)	60	90

As standard, the cables are 33 ft (10 m) long. Other cable lengths are available on request. See [List of variants](#) on page 10.

The number and dimensions of cables depend on the motor size.

Cable entry

The stainless-steel plug is fastened with a union nut. The nut and O-rings provide sealing against ingress of the liquid.

The plug is filled with a two-component compound that is cast into the plug around the leads of the cable. This prevents the ingress of water into the motor through the cable in case of cable breakage or rough handling in connection with installation or service.

Sensors

As standard, the pump has two thermal switches incorporated in the motor windings to protect the motor against overheating.

Operating conditions

The pumps are designed for intermittent operation (S3). When completely submerged, the pumps can also operate continuously (S1).

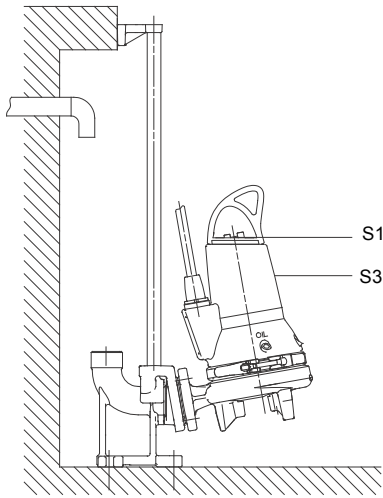

Fig. 9 Operation levels

TM06 5749 0116

S3, intermittent operation

S3 operation is a series of identical duty cycles (TC) each with a constant load for a period, followed by a rest period. Thermal equilibrium is not reached during the cycle. See fig. 10.

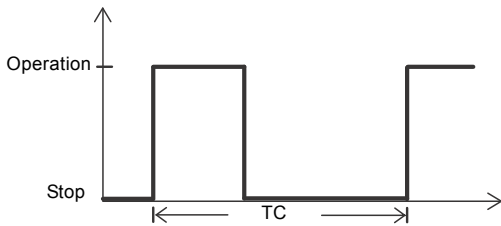

Fig. 10 S3 operation

TM04 4527 1509

S1, continuous operation

In this operating mode, the pump can operate continuously without having to be stopped for cooling. See fig. 11. Being completely submerged, the pump is sufficiently cooled by the surrounding liquid. See fig. 9.

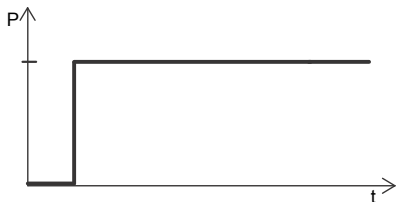

Fig. 11 S1 operation

TM04 5228 1509

Pumped liquids

pH value: 4-10.

Liquid temperature: 32-104 °F (0-40 °C).

When pumping liquids with a density and/or a kinematic viscosity higher than that of water, use motors with correspondingly higher outputs.

For short periods of maximum 3 minutes, temperatures up to 140 °F (60 °C) are allowed (non-Ex versions only).

Sound pressure level

The sound pressure level of the pump is lower than the limiting values stated in the EC Machinery Directive (2006/42/EC).

Motor range

Output power [hp (kW)]	Number of poles
2.0 (1.5)	2
3.0 (2.6)	2
4.0 (3.1)	2
5.5 (4.0)	2

Variable frequency drive operation

In principle, all three-phase pumps can be connected to a variable frequency drive.

However, variable frequency drive operation often exposes the motor insulation system to a heavier load and cause the motor to be more noisy than usual due to eddy currents caused by voltage peaks.

In addition, large motors driven via a variable frequency drive are loaded by bearing currents.

For more information, see the installation and operating instructions for the relevant variable frequency drive in Grundfos Product Center at www.grundfos.com.

Approvals

The standard versions of SEG 60 Hz pumps have been approved by CSA, and the explosion-proof versions hold an FM type examination certificate.

Approval standards

These pumps are CSA-approved according to UL778 and C22.2 No 108, No 0.4, No 30, No 145 and No 60529. The pumps are FM-approved according to FM 3600, FM 3615 and FM 3650 as well as ANSI/IEC 60529.

Ex approval

The SEG 60 Hz pumps have the following explosion protection classification: Class I, Division 1, Groups C and D hazardous locations, T3C, IP68.

Standard	Code	Description
	Class I	= The explosive atmosphere is caused by gas or vapors (permitted class).
	Division 1	= Area classification (permitted division).
FM 3600	Group C and D	= Classification of gases.
FM 3615	T3C	= The maximum surface temperature is 320 °F (160 °C).
FM 3650	IP68	= The enclosure class is according to IEC 60529.

Wiring diagrams

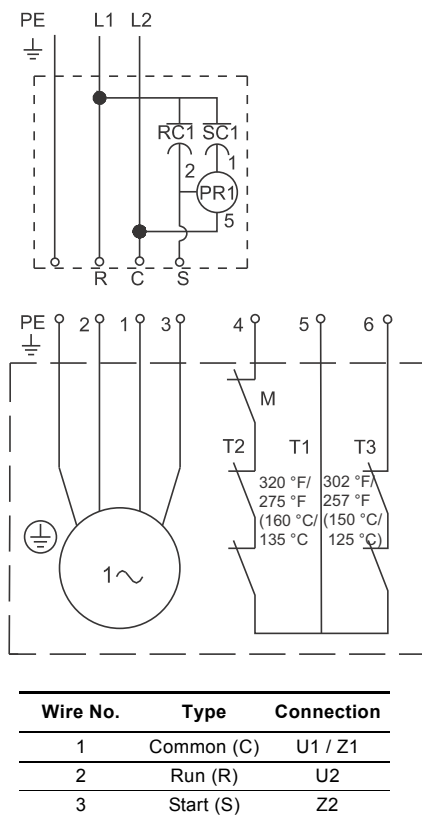

Fig. 12 Wiring diagram for single-phase SEG pumps. See table below.

Pump type	Cs starting capacitor		Cr run capacitor	
	[μ F]	[V]	[μ F]	[V]
SEG	150	230	30	450

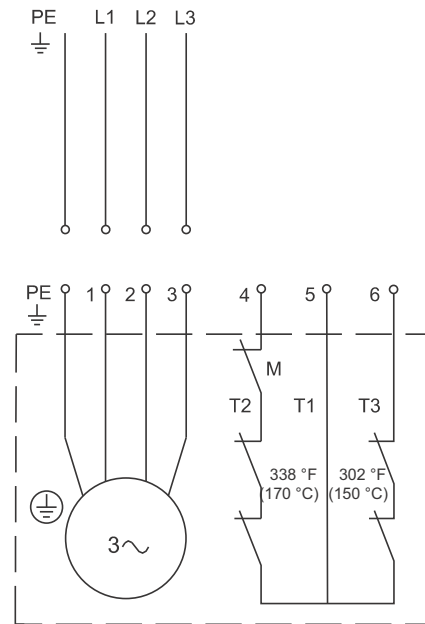

Fig. 13 Wiring diagram for three-phase SEG pumps

TM06 5693 0316

TM06 5694 0316

9. Curve charts

How to read the performance curves

The curves on the following pages apply to SEG pumps.

SEG	Page
SEG.A15.20.2.1.603	21
SEG.A15.20.R2.2.1.603	22
SEG.A15.20.R1.2.1.603	23
SEG.A15.20.2.60H/L/M	24
SEG.A15.20.R2.2.60H/L/M	25
SEG.A15.20.R1.2.60H/L/M	26
SEG.A15.30.2.60H/L/M	27
SEG.A15.40.2.60H/L/M	28
SEG.A15.55.2.60H/L/M	29
SEG.A20.30.2.60H/L/M	30
SEG.A20.40.2.60H/L/M	31
SEG.A20.55.2.60H/L/M	32

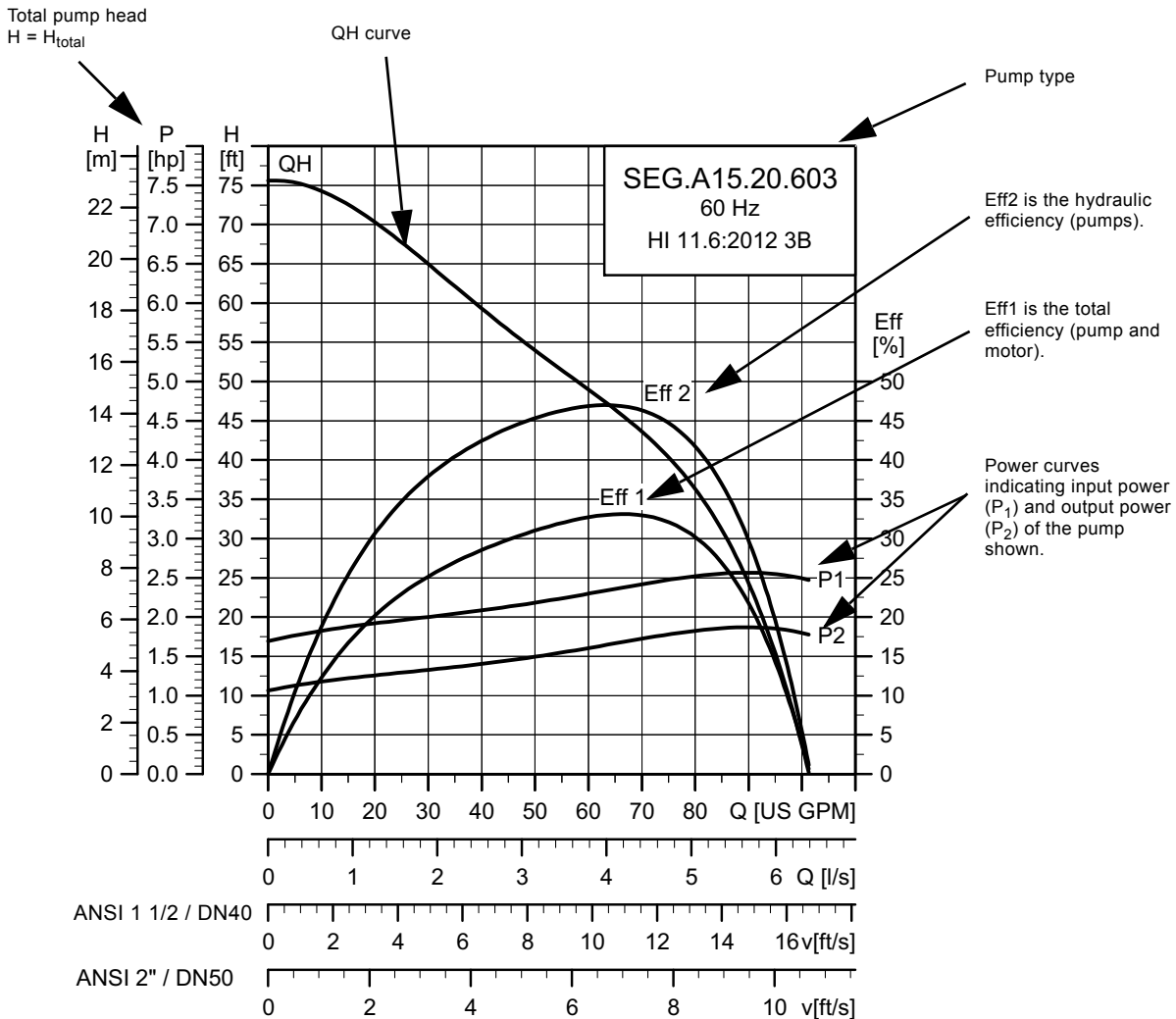

TM05 8126 4715

Note: The pumps are tested according to ANSI HI 11.6:2012 3B tolerance. Testing equipment and measuring instruments are designed and calibrated according to the standards mentioned. The pumps are approved according to tolerances for entire curves, specified in grade 3B.

Curve conditions

The guidelines below apply to the curves on pages 21 to 32.

- Tolerances are according to HI 11.6:2012 3B.
- The curves show the pump performance with different impeller diameters at the rated speed.
- The curves apply to the pumping of airless water at a temperature of 68 °F (20 °C) and a kinematic viscosity of 1 cSt (1 mm²/s).
- The Eff curves show the efficiency of the pump for the different impeller diameters.
- In the case of other densities than 62.4 lb/ft³ (1000 kg/m³), the outlet pressure is proportional to the density.
- When pumping liquids with a density higher than 62.4 lb/ft³ (1000 kg/m³), motors with correspondingly higher outputs must be used.

Calculation of total head

The total pump head consists of the height difference between the measuring points + the differential head + the dynamic head.

$$H_{\text{total}} = H_{\text{geo}} + H_{\text{stat}} + H_{\text{dyn}}$$

H_{geo} : Height difference between measuring points.

H_{stat} : Differential head across the pump.

H_{dyn} : Calculated values based on the velocity of the pumped liquid on the inlet and outlet sides of the pump.

Performance tests

The requested duty point of every pump is tested according to HI 11.6:2012 3B, and without certification.

In the case of pumps ordered on the basis of impeller diameter only (no requested duty point), the pump is tested at a duty point which is 2/3 of the maximum flow of the published performance curve which is related to the ordered impeller diameter (according to HI 11.6:2012 3B).

If the customer requires either more points on the curve to be checked or certain minimum performances or certificates, individual measurements must be made, and a certificate can be ordered when the pump is ordered.

Certificates

Certificates must be confirmed for every order and are available on request. See [List of variants](#) on page 10.

Witness test

It is possible for the customer to witness the testing procedure according to HI 11.6:2012 3B.

The witness test is not a certificate and will not result in a written statement from Grundfos. The witness test itself is only a guarantee that everything is carried out as prescribed in the testing procedure.

If the customer wants to witness the test of the pump performance, this request must be stated on the order.

10. Performance curves and technical data

SEG.A15.20.(EX).2.1.603

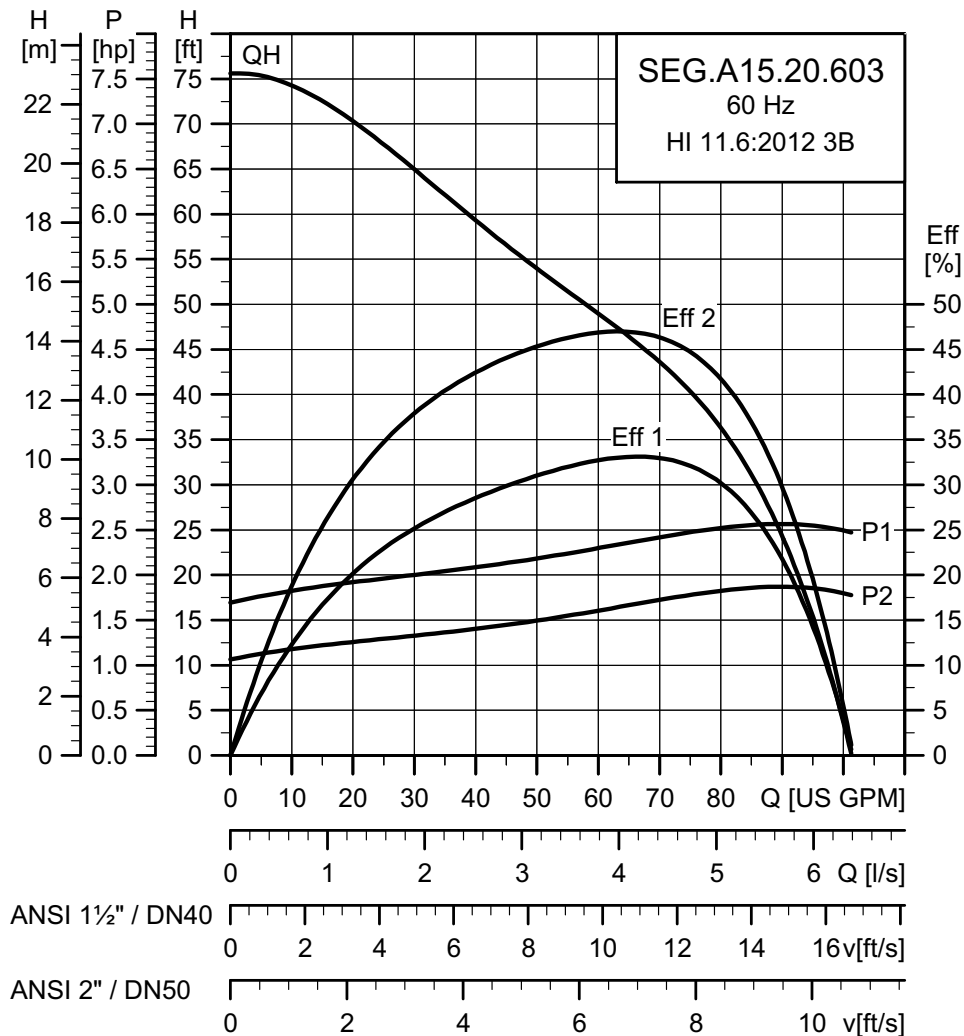

TM05 8126 0514

Electrical data

Voltage [V]	P		Number of poles	rpm	Starting method	I_n			I_{start}			η_{motor} [%]				Cos ϕ		Moment of inertia [lb·ft ² (kg·m ²)]	Breakdown torque, M_{max} [lb·ft (Nm)]
	P1 [hp (kW)]	P2 [hp (kW)]				1/2	3/4	1/1	1/2	3/4	1/1	1/2	3/4	1/1	1/2	3/4	1/1		
1 x 208-230	2.7 (2.0)	2.0 (1.5)	2	3400	DOL	12.0	48	0.6	0.72	0.74	0.28	0.53	0.76	0.04746 (0.0020)	6.05 (8.2)				

Pump data

Impeller type	Maximum solids size	Maximum number of starts per hour	Maximum installation depth	Enclosure class	Insulation class	Maximum liquid temperature	pH
	[in. (mm)]		[ft (m)]			[°F (°C)]	
Semi-open	Grinder system	30	33 (10)	IP68	F	104 (40)	4-10

SEG.A15.20.R2.(EX).2.1.603

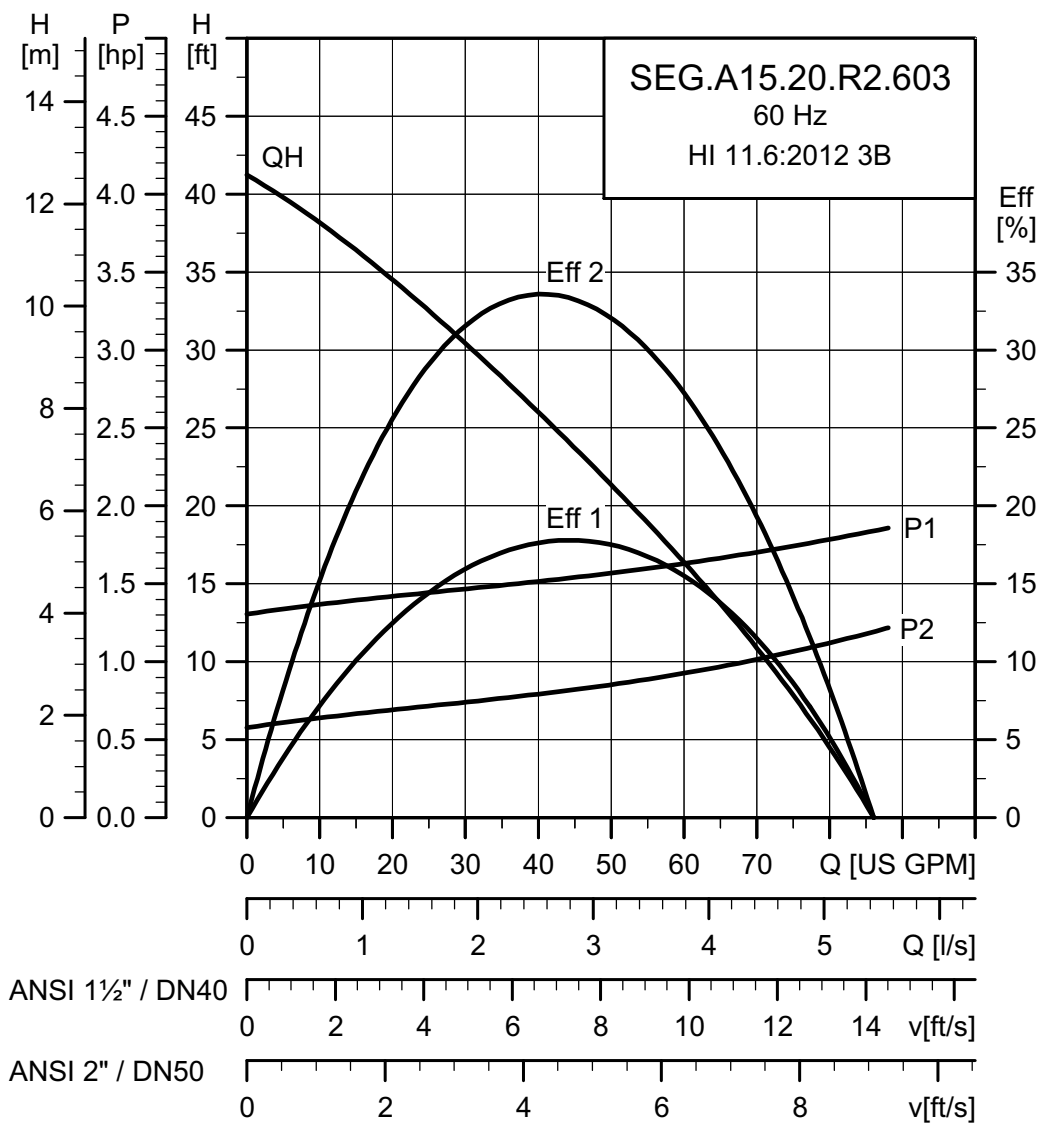

TM06 1312 2214

Electrical data

Voltage [V]	P1 [hp (kW)]	P2 [hp (kW)]	Number of poles	rpm	Starting method	I_N			I_{start}			η_{motor} [%]			Cos ϕ			Moment of inertia [lb·ft ² (kg·m ²)]	Breakdown torque, M_{max} [lb·ft (Nm)]
						[A]	[A]	[A]	1/2	3/4	1/1	1/2	3/4	1/1	1/2	3/4	1/1		
1 x 208-230	1.9 (1.4)	1.2 (0.9)	2	3490	DOL	7	48	0.59	0.68	0.69	0.77	0.80	0.87	0.01661 (0.0007)	6.05 (8.2)				

Pump data

Impeller type	Maximum solids size	Maximum number of starts per hour	Maximum installation depth	Enclosure class	Insulation class	Maximum liquid temperature	pH
	[in. (mm)]		[ft (m)]			[°F (°C)]	
Semi-open	Grinder system	30	33 (10)	IP68	F	104 (40)	4-10

SEG.A15.20.R1.(EX).2.1.603

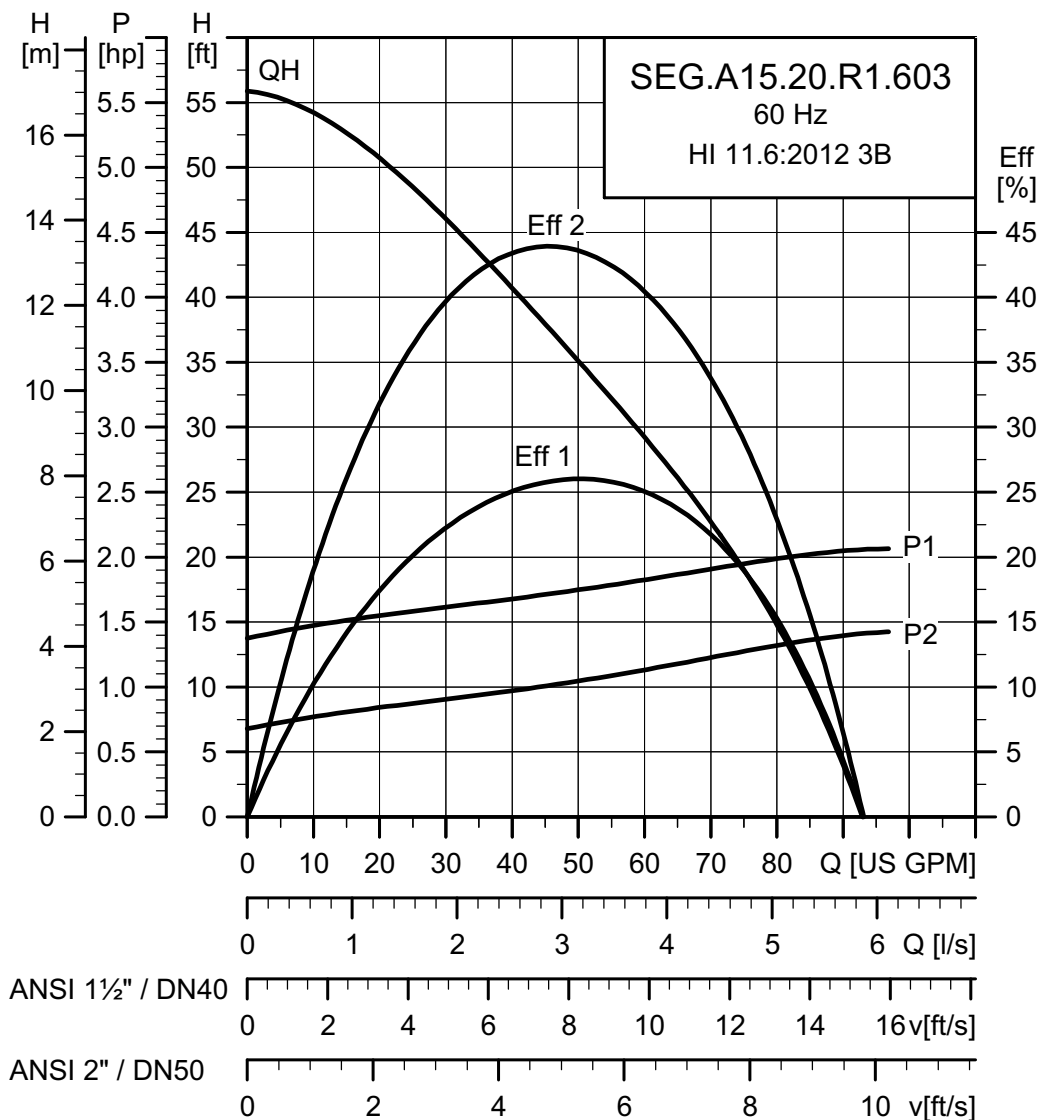

TM06 1314 2214

Electrical data

Voltage [V]	P1 [hp (kW)]	P2 [hp (kW)]	Number of poles	rpm	Starting method	I_N			I_{start}			η_{motor} [%]			Cos ϕ			Moment of inertia [lb·ft ² (kg·m ²)]	Breakdown torque, M_{max} [lb·ft (Nm)]
						[A]	[A]	[A]	[A]	[A]	[A]	[A]	[A]	[A]	[A]	[A]	[A]		
1 x 208-230	2.1 (1.6)	1.6 (1.2)	2	3450	DOL	8.0	48	0.66	0.73	0.74	0.80	0.82	0.91	0.01661 (0.0007)	6.05 (8.2)				

Pump data

Impeller type	Maximum solids size	Maximum number of starts per hour	Maximum installation depth	Enclosure class	Insulation class	Maximum liquid temperature	pH
	[in. (mm)]		[ft (m)]				
Semi-open	Grinder system	30	33 (10)	IP68	F	104 (40)	4-10

SEG.A15.20.(EX).2.60H/L/M

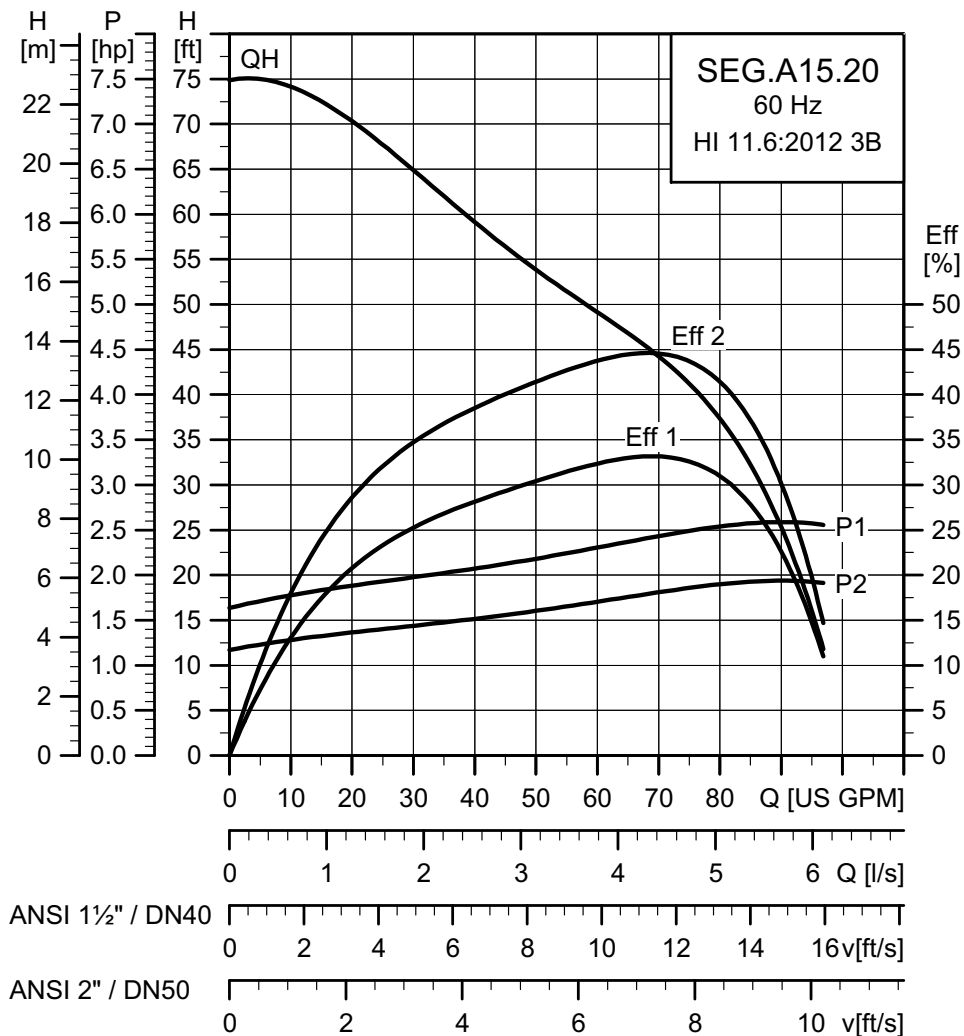

TM05 8127 0514

Electrical data

Voltage [V]	P1 [hp (kW)]	P2 [hp (kW)]	Number of poles	rpm	Starting method	I_N			I_{start}			η_{motor} [%]				$\cos \phi$		Moment of inertia [lb·ft ² (kg·m ²)]	Breakdown torque, M_{max} [lb·ft (Nm)]
						[A]	[A]	1/2	3/4	1/1	1/2	3/4	1/1	1/2	3/4	1/1			
3 x 460	2.5 (1.9)	2.0 (1.5)	2	3405	DOL	4.0	22	0.60	0.76	0.78	0.70	0.75	0.80	0.01661 (0.0007)	11.06 (15.0)				
3 x 575	2.5 (1.9)	2.0 (1.5)	2	3422	DOL	3.0	16	0.69	0.76	0.78	0.63	0.74	0.79	0.01661 (0.0007)	11.06 (15.0)				
3 x 200-230	2.5 (1.9)	2.0 (1.5)	2	3422	DOL	7.0	40	0.69	0.76	0.78	0.55	0.69	0.79	0.01661 (0.0007)	12.01 (16.4)				

Pump data

Impeller type	Maximum solids size	Maximum number of starts per hour	Maximum installation depth	Enclosure class	Insulation class	Maximum liquid temperature	pH
	[in. (mm)]	[ft (m)]	[°F (°C)]				
Semi-open	Grinder system	30	33 (10)	IP68	F	104 (40)	4-10

SEG.A15.20.R2.(EX).2.60H/M

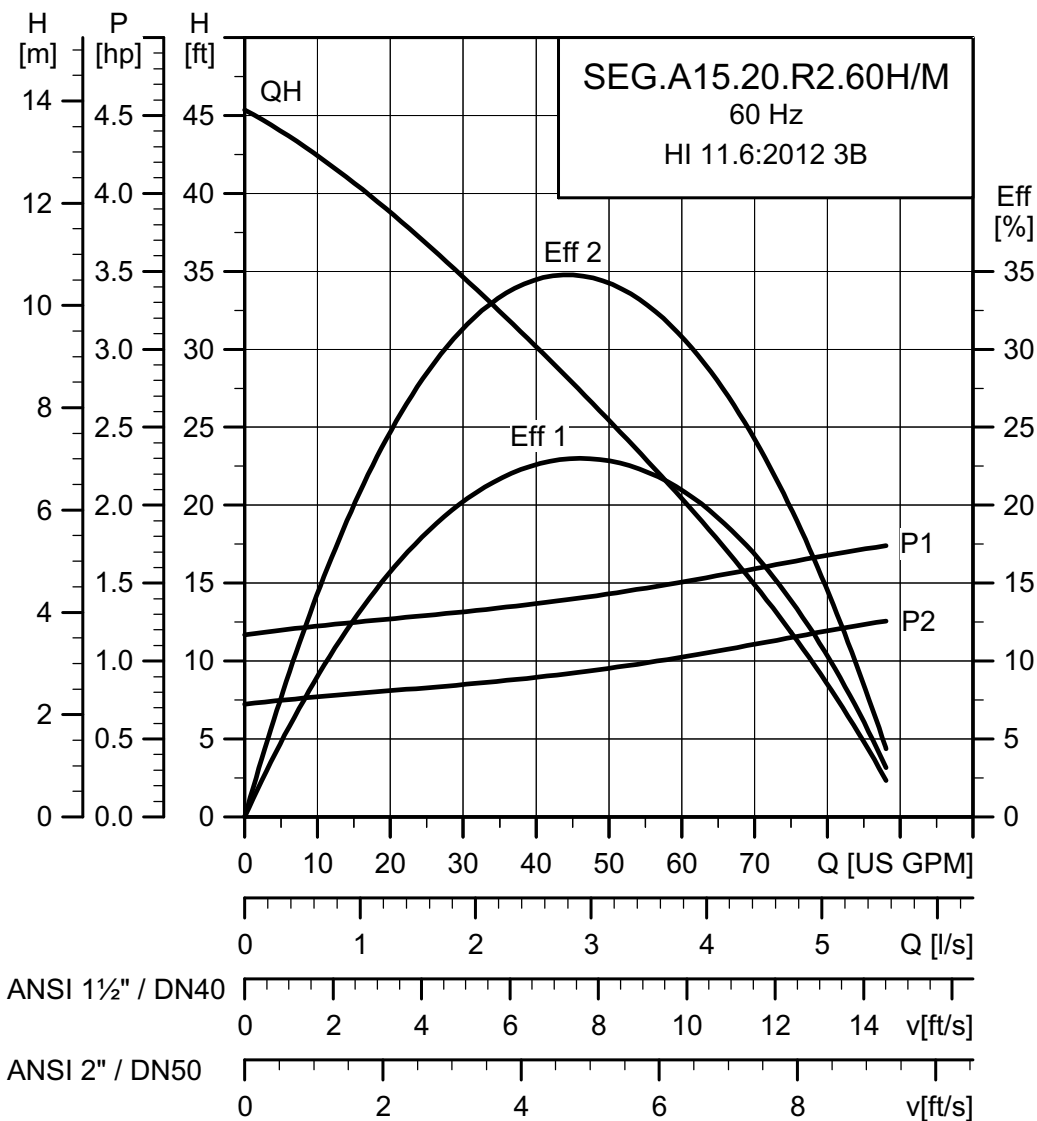

TM06 1313 2214

Electrical data

Voltage [V]	P		Number of poles	rpm	Starting method	I_N		η_{motor} [%]			Cos φ			Moment of inertia [lb·ft ² (kg·m ²)]	Breakdown torque, M_{max} [lb·ft (Nm)]
	P1 [hp (kW)]	P2 [hp (kW)]				I_N [A]	I_{start} [A]	1/2	3/4	1/1	1/2	3/4	1/1		
3 x 460	1.6 (1.2)	1.2 (0.9)	2	3490	DOL	3.0	20	0.61	0.67	0.74	0.42	0.52	0.61	0.01661 (0.0007)	11.06 (15.0)
3 x 200-230	1.6 (1.2)	1.2 (0.9)	2	3497	DOL	6.0	40	0.61	0.67	0.73	0.42	0.52	0.61	0.01661 (0.0007)	12.01 (16.4)

Pump data

Impeller type	Maximum solids size	Maximum number of starts per hour	Maximum installation depth	Enclosure class	Insulation class	Maximum liquid temperature	pH
	[in. (mm)]		[ft (m)]			[°F (°C)]	
Semi-open	Grinder system	30	33 (10)	IP68	F	104 (40)	4-10

SEG.A15.20.R1.(EX).2.60H/M

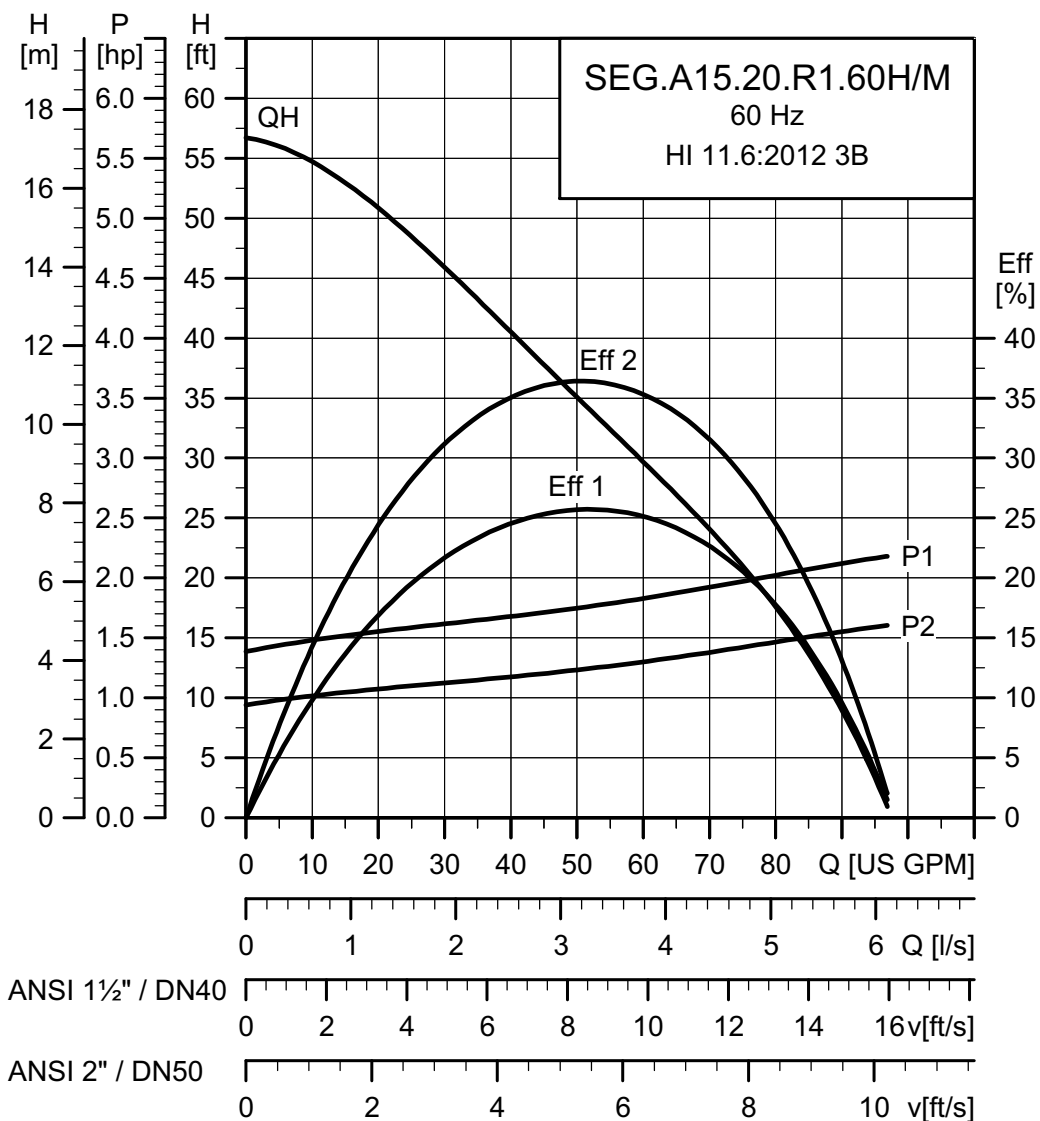

TM06 1315 2214

Electrical data

Voltage [V]	P1 P2 [hp (kW)]		Number of poles	rpm	Starting method	I_N I_{start}		η_{motor} [%]			$\cos \phi$			Moment of inertia [lb·ft ² (kg·m ²)]	Breakdown torque, M_{max} [lb·ft (Nm)]
						[A]	[A]	1/2	3/4	1/1	1/2	3/4	1/1		
3 x 460	2.0 (1.5)	1.6 (1.2)	2	3450	DOL	3.0	20	0.65	0.73	0.78	0.48	0.61	0.72	0.01661 (0.0007)	11.06 (15.0)
3 x 200-230	2.1 (1.6)	1.6 (1.2)	2	3460	DOL	6.0	40	0.65	0.73	0.77	0.48	0.61	0.72	0.01661 (0.0007)	12.01 (16.4)

Pump data

Impeller type	Maximum solids size	Maximum number of starts per hour	Maximum installation depth	Enclosure class	Insulation class	Maximum liquid temperature	pH
	[in. (mm)]		[ft (m)]			[°F (°C)]	
Semi-open	Grinder system	30	33 (10)	IP68	F	104 (40)	4-10

SEG.A15.30.(EX).2.60H/L/M

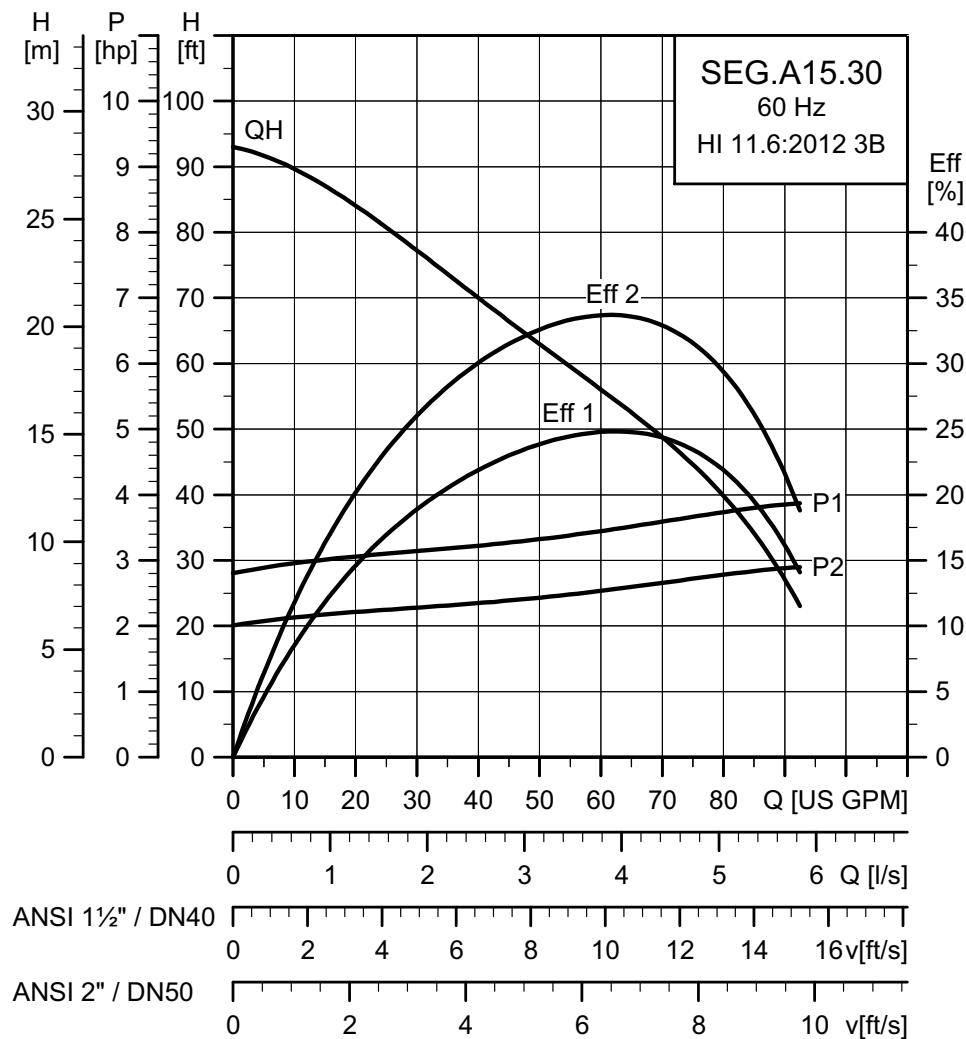

TM05 8128 0514

Electrical data

Voltage [V]	P1 [hp (kW)]	P2 [hp (kW)]	Number of poles	rpm	Starting method	I_N			I_{start}			η_{motor} [%]				$\cos \varphi$		Moment of inertia	Breakdown torque, M_{max}
						[A]	[A]	1/2	3/4	1/1	1/2	3/4	1/1	1/2	3/4	1/1	[lb·ft ² (kg·m ²)]	[Nm]	
3 x 460	3.8 (2.8)	3.0 (2.2)	2	3500	DOL	5.0	34	0.70	0.75	0.78	0.70	0.81	0.84	0.30849 (0.0130)	13.42 (18.2)				
3 x 575	3.8 (2.8)	3.0 (2.2)	2	3500	DOL	4.0	27	0.70	0.75	0.78	0.70	0.81	0.84	0.30849 (0.0130)	13.42 (18.2)				
3 x 200-230	3.8 (2.8)	3.0 (2.2)	2	3500	DOL	9.0	65	0.70	0.75	0.78	0.70	0.81	0.84	0.30849 (0.0130)	13.42 (18.2)				

Pump data

Impeller type	Maximum solids size	Maximum number of starts per hour	Maximum installation depth	Enclosure class	Insulation class	Maximum liquid temperature	pH
	[in. (mm)]	[ft (m)]	[°F (°C)]				
Semi-open	Grinder system	30	33 (10)	IP68	F	104 (40)	4-10

SEG.A15.40.(EX).2.60H/L/M

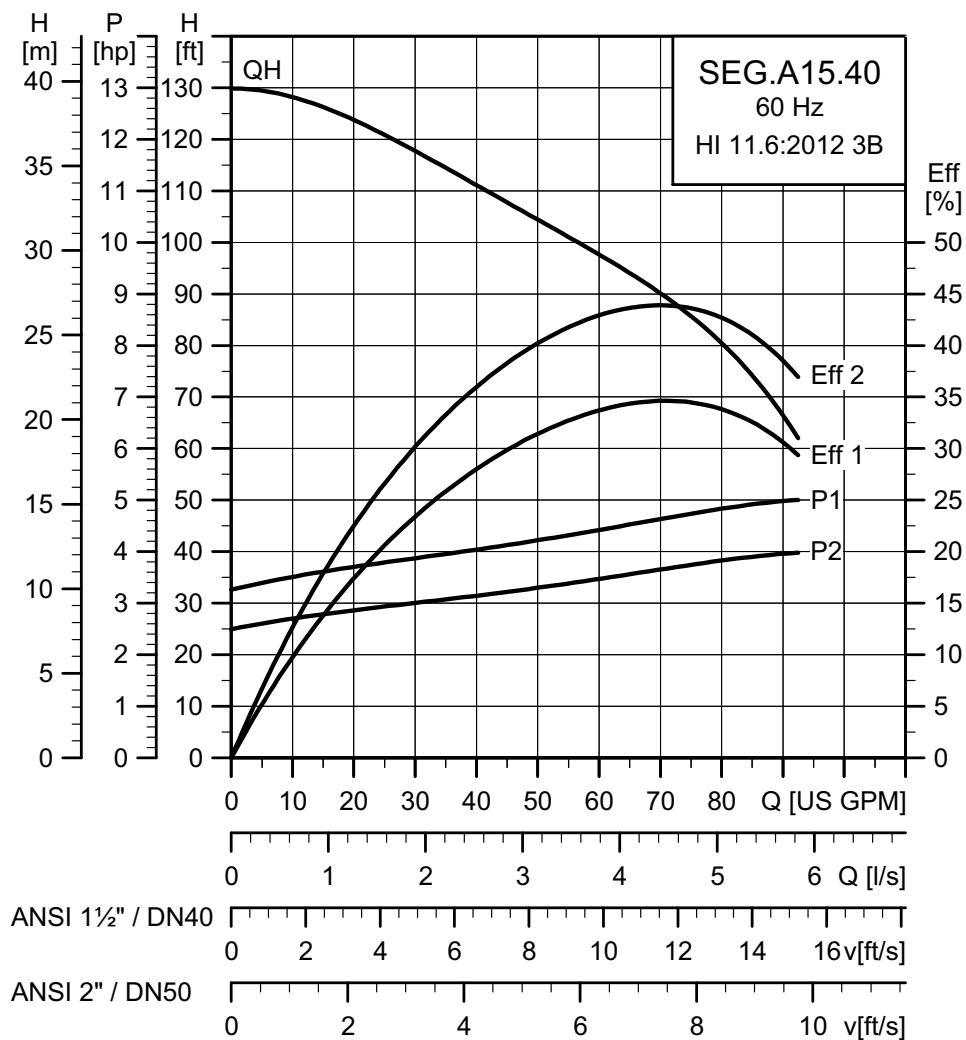

TM05 8129 0514

Electrical data

Voltage [V]	P1 [hp (kW)]	P2 [hp (kW)]	Number of poles	rpm	Starting method	I_N			I_{start}			η_{motor} [%]			Cos ϕ			Moment of inertia [lb·ft ² (kg·m ²)]	Breakdown torque, M_{max} [lb·ft (Nm)]
						[A]	[A]	1/2	3/4	1/1	1/2	3/4	1/1	1/2	3/4	1/1			
3 x 460	5.2 (3.9)	4.0 (3.1)	2	3490	DOL	6.0	43	0.75	0.78	0.80	0.75	0.83	0.88	0.52206 (0.0220)	16.44 (22.3)				
3 x 575	5.4 (4.0)	4.0 (3.1)	2	3498	DOL	5.0	36	0.75	0.77	0.78	0.70	0.80	0.85	0.52206 (0.0220)	16.44 (22.3)				
3 x 200-230	5.2 (3.9)	4.0 (3.1)	2	3498	DOL	12.0	89.5	0.72	0.77	0.80	0.70	0.80	0.85	0.52206 (0.0220)	18.00 (24.4)				

Pump data

Impeller type	Maximum solids size	Maximum number of starts per hour	Maximum installation depth	Enclosure class	Insulation class	Maximum liquid temperature	pH
	[in. (mm)]		[ft (m)]			[°F (°C)]	
Semi-open	Grinder system	30	33 (10)	IP68	F	104 (40)	4-10

SEG.A15.55.(EX).2.60H/L/M

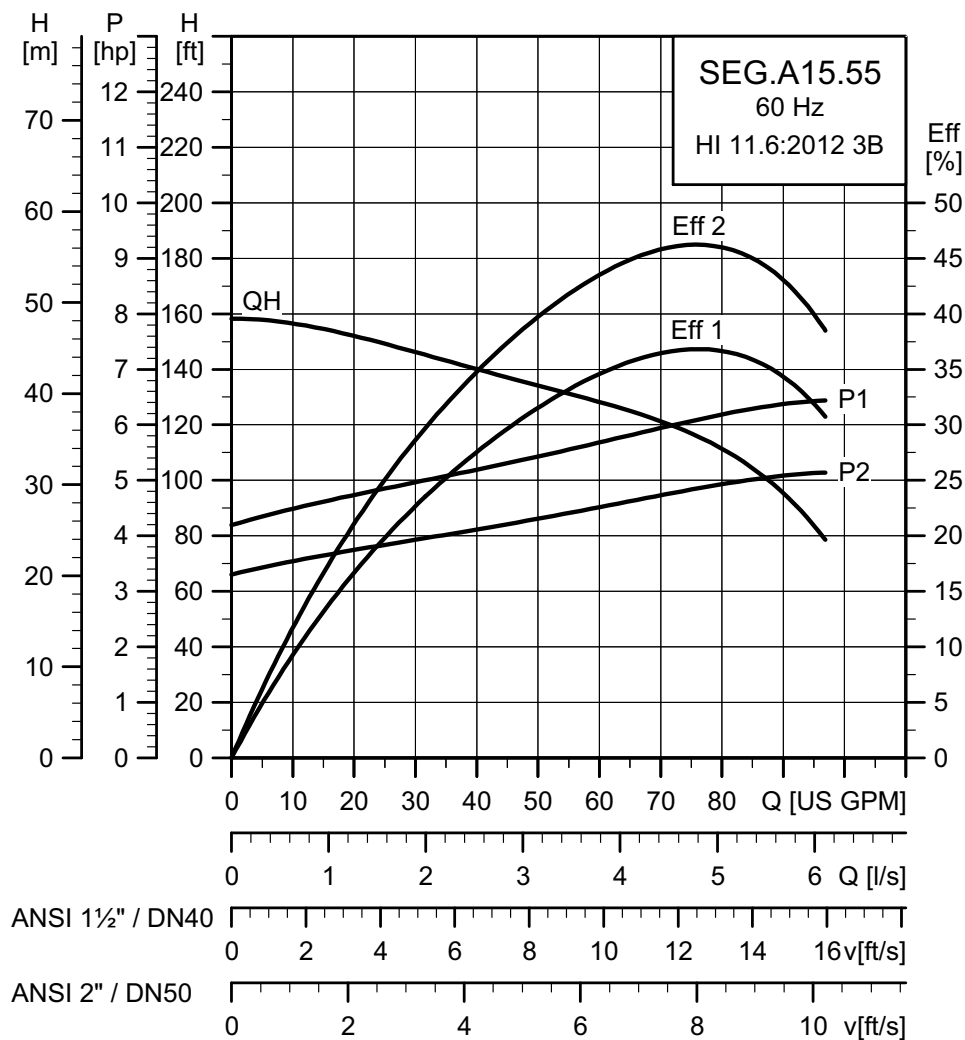

TM05 8130 0514

Electrical data

Voltage [V]	P1 [hp (kW)]	P2 [hp (kW)]	Number of poles	rpm	Starting method	I_N			I_{start}			$\eta_{motor} [\%]$			Cos φ		Moment of inertia	Breakdown torque, M_{max}
						[A]	[A]	1/2	3/4	1/1	1/2	3/4	1/1	[lb-ft ² (kg-m ²)]	[Nm]			
3 x 460	6.8 (5.1)	5.5 (4.0)	2	3452	DOL	8.0	43	0.77	0.80	0.79	0.80	0.88	0.90	0.52206 (0.0220)	16.44 (22.3)			
3 x 575	6.8 (5.1)	5.5 (4.0)	2	3463	DOL	6.0	36	0.76	0.80	0.79	0.80	0.88	0.90	0.52206 (0.0220)	16.44 (22.3)			
3 x 200-230	6.7 (5.0)	5.5 (4.0)	2	3463	DOL	14.0	89.5	0.76	0.80	0.80	0.66	0.79	0.91	0.52206 (0.0220)	18.00 (24.4)			

Pump data

Impeller type	Maximum solids size	Maximum number of starts per hour	Maximum installation depth	Enclosure class	Insulation class	Maximum liquid temperature	pH
	[in. (mm)]		[ft (m)]			[°F (°C)]	
Semi-open	Grinder system	30	33 (10)	IP68	F	104 (40)	4-10

SEG.A20.30.(EX).2.60H/L/M

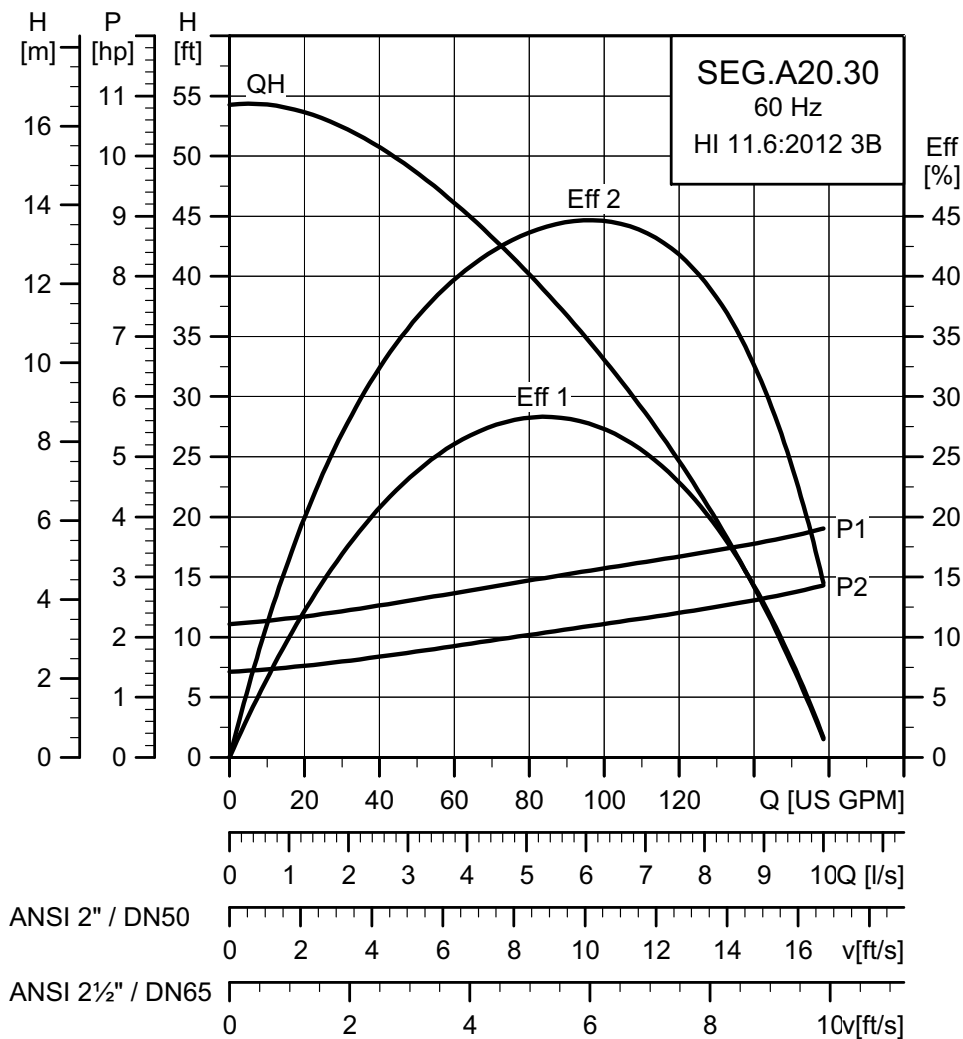

TM05 8131 0514

Electrical data

Voltage [V]	P1 [hp (kW)]	P2 [hp (kW)]	Number of poles	rpm	Starting method	I_N			I_{start}			η_{motor} [%]				$\cos \varphi$		Moment of inertia	Breakdown torque, M_{max}
						[A]	[A]	1/2	3/4	1/1	1/2	3/4	1/1	1/2	3/4	1/1	[lb-ft ² (kg-m ²)]	[Nm]	
3 x 460	3.8 (2.8)	3.0 (2.2)	2	3500	DOL	5.0	34	0.70	0.75	0.78	0.70	0.81	0.84	0.30849 (0.0130)	13.42 (18.2)				
3 x 575	3.8 (2.8)	3.0 (2.2)	2	3500	DOL	4.0	27	0.70	0.75	0.78	0.70	0.81	0.84	0.30849 (0.0130)	13.42 (18.2)				
3 x 200-230	3.8 (2.8)	3.0 (2.2)	2	3500	DOL	9.0	65	0.70	0.75	0.78	0.70	0.81	0.84	0.30849 (0.0130)	13.42 (18.2)				

Pump data

Impeller type	Maximum solids size	Maximum number of starts per hour	Maximum installation depth	Enclosure class	Insulation class	Maximum liquid temperature	pH
	[in. (mm)]	[ft (m)]	[°F (°C)]				
Semi-open	Grinder system	30	33 (10)	IP68	F	104 (40)	4-10

SEG.A20.40.(EX).2.60H/L/M

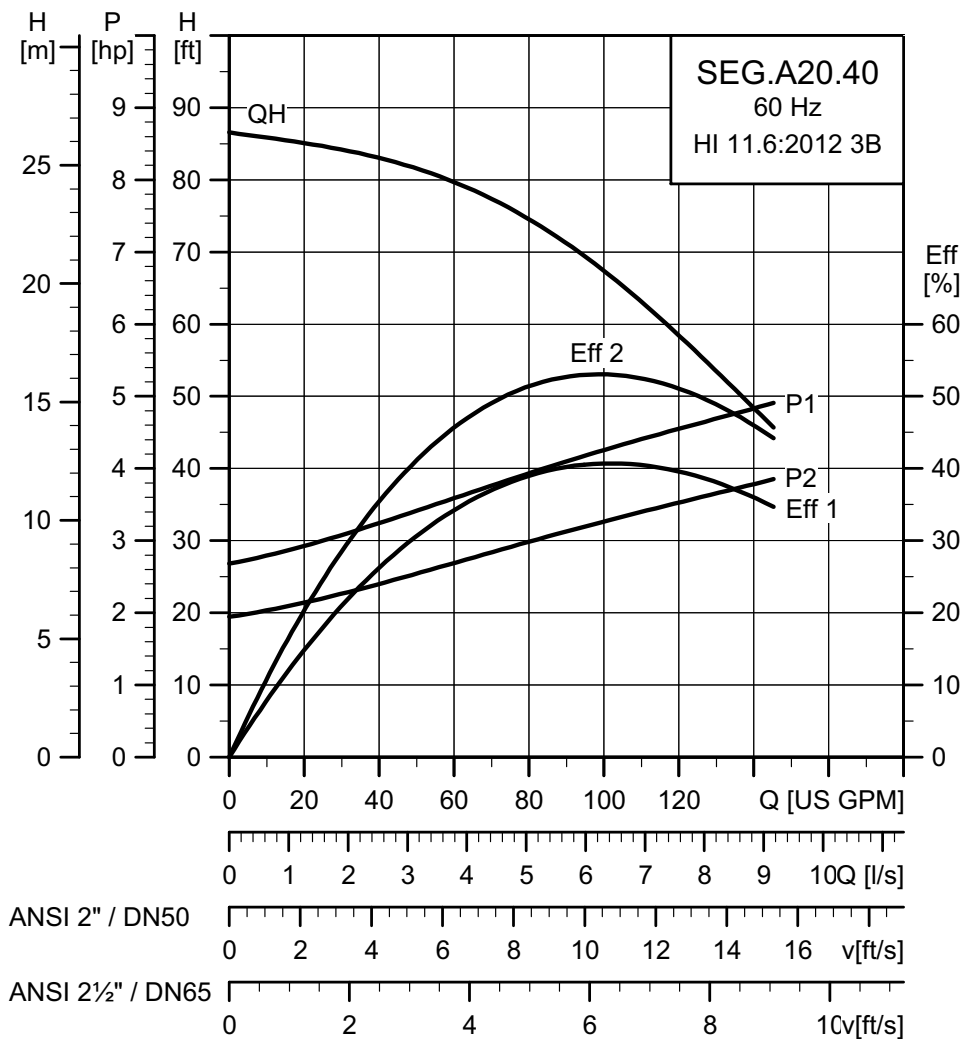

TM05 8132 0514

Electrical data

Voltage [V]	P1 [hp (kW)]	P2 [hp (kW)]	Number of poles	rpm	Starting method	I_N			I_{start}			$\eta_{motor} [\%]$			$\cos \varphi$		Moment of inertia [lb-ft ² (kg-m ²)]	Breakdown torque, M_{max} [lb-ft (Nm)]
						[A]	[A]	1/2	3/4	1/1	1/2	3/4	1/1	1/2	3/4	1/1		
3 x 460	5.2 (3.9)	4.0 (3.1)	2	3490	DOL	6.0	43	0.75	0.78	0.80	0.75	0.83	0.88	0.52206 (0.0220)	16.44 (22.3)			
3 x 575	5.4 (4.0)	4.0 (3.1)	2	3498	DOL	5.0	36	0.75	0.77	0.78	0.70	0.80	0.85	0.52206 (0.0220)	16.44 (22.3)			
3 x 200-230	5.2 (3.9)	4.0 (3.1)	2	3498	DOL	12.0	89.5	0.72	0.77	0.80	0.70	0.80	0.85	0.52206 (0.0220)	18.00 (24.4)			

Pump data

Impeller type	Maximum solids size	Maximum number of starts per hour	Maximum installation depth	Enclosure class	Insulation class	Maximum liquid temperature	pH
	[in. (mm)]		[ft (m)]			[°F (°C)]	
Semi-open	Grinder system	30	33 (10)	IP68	F	104 (40)	4-10

SEG.A20.55.(EX).2.60H/L/M

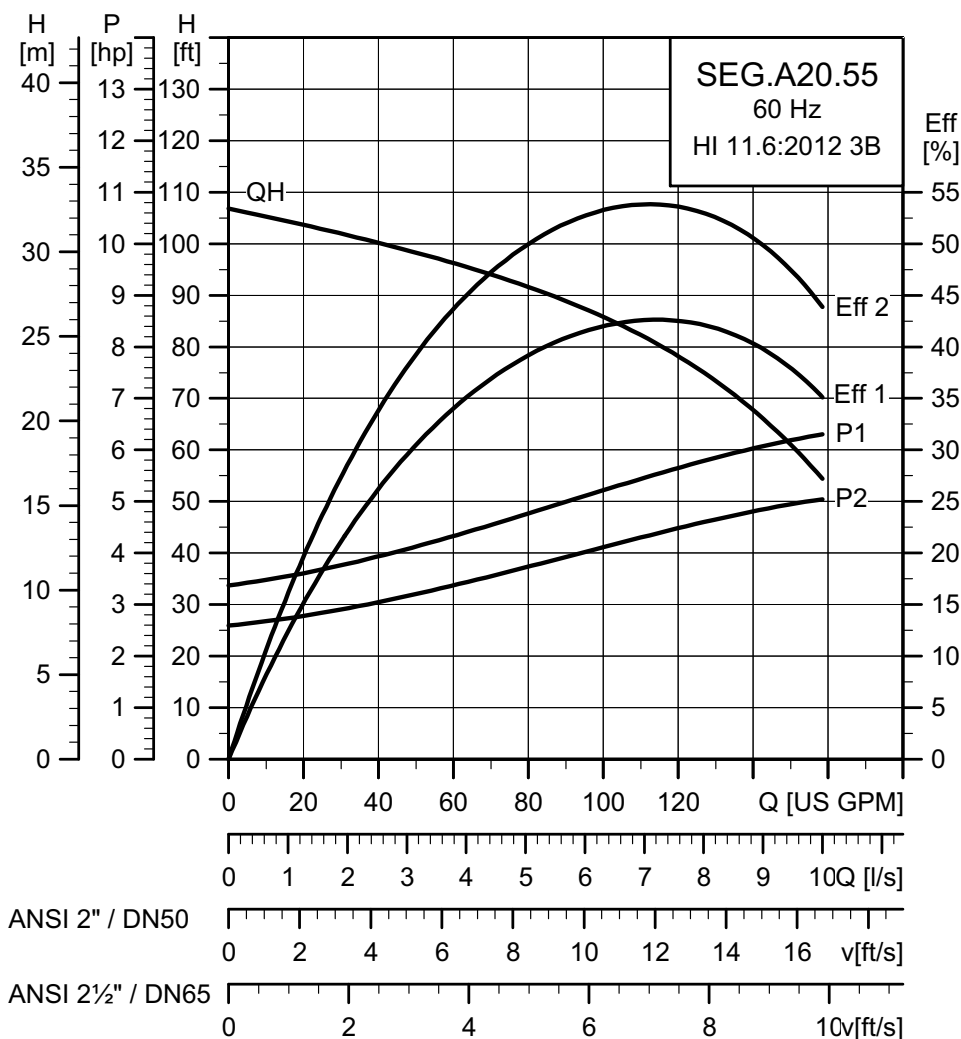

TM05 8133 0514

Electrical data

Voltage [V]	P1 [hp (kW)]	P2 [hp (kW)]	Number of poles	rpm	Starting method	I_N			I_{start}			η_{motor} [%]			$\cos \phi$			Moment of inertia	Breakdown torque, M_{max}
						[A]	[A]	1/2	3/4	1/1	1/2	3/4	1/1	1/2	3/4	1/1	[lb-ft ² (kg-m ²)]	[Nm]	
3 x 460	6.8 (5.1)	5.5 (4.0)	2	3452	DOL	8.0	43	0.77	0.80	0.79	0.80	0.88	0.90	0.52206 (0.0220)	16.44 (22.3)				
3 x 575	6.8 (5.1)	5.5 (4.0)	2	3463	DOL	6.0	36	0.76	0.80	0.79	0.80	0.88	0.90	0.52206 (0.0220)	16.44 (22.3)				
3 x 200-230	6.7 (5.0)	5.5 (4.0)	2	3463	DOL	14.0	89.5	0.76	0.80	0.80	0.66	0.79	0.91	0.52206 (0.0220)	18.00 (24.4)				

Pump data

Impeller type	Maximum solids size	Maximum number of starts per hour	Maximum installation depth	Enclosure class	Insulation class	Maximum liquid temperature	pH
	[in. (mm)]		[ft (m)]			[°F (°C)]	
Semi-open	Grinder system	30	33 (10)	IP68	F	104 (40)	4-10

11. Dimensions and weights

Auto-coupling installation

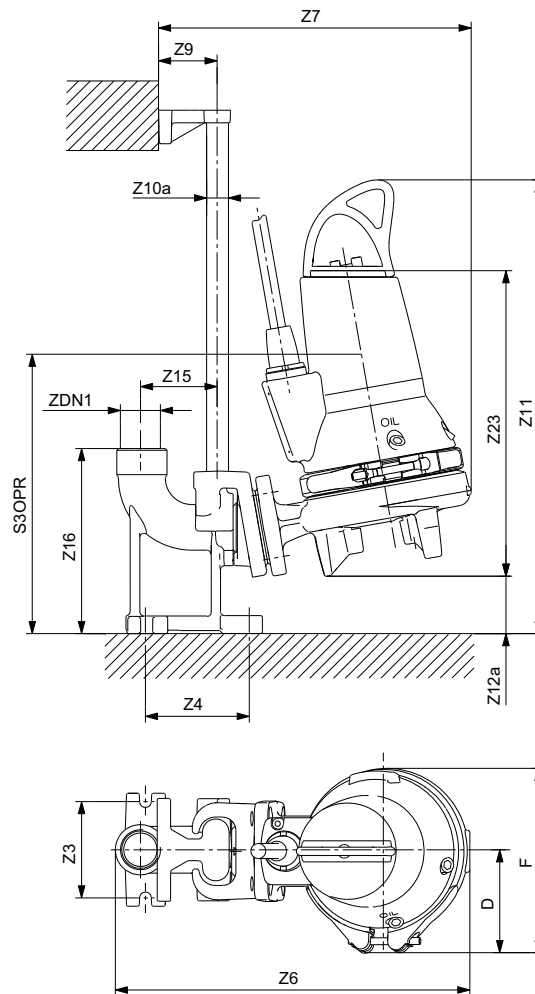

Fig. 14 Installation on auto coupling

TM06 5743 0116

SEG.A15

Power	D	F	Z3	Z4	Z6	Z7	Z9	Z10a	Z11	Z12a	Z15	Z16	Z23	S3OPR	ZDN1
[hp (kW)]	[in. (mm)]														
2.0 (1-phase) (1.5)	3.9 (99)	8.5 (216)	4.53 (115)	4.65 (118)	16.57 (421)	14.61 (371)	2.76 (70)	3/4" - 1"	22.08 (561)	2.6 (66)	3.54 (90)	8.66 (220)	14.3 (363)	14.2 (361)	NPT 1 1/2"
2.0 (3-phase) (1.5)	3.9 (99)	8.5 (216)	4.53 (115)	4.65 (118)	16.57 (421)	14.61 (371)	2.76 (70)		21.50 (546)	2.6 (66)	3.54 (90)	8.66 (220)	14.5 (368)	13.6 (346)	NPT 1 1/2"
3.0 (2.6)	4.69 (119)	10.08 (256)	4.53 (115)	4.65 (118)	18.19 (462)	16.22 (412)	2.76 (70)		24.17 (614)	3.15 (80)	3.54 (90)	8.66 (220)	13.7 (348)	14.6 (371)	NPT 1 1/2"
4.0 and 5.5 (3.1 and 4.0)	4.69 (119)	10.08 (256)	4.53 (115)	4.65 (118)	18.19 (462)	16.22 (412)	2.76 (70)		25.63 (651)	3.15 (80)	3.54 (90)	8.66 (220)	17.0 (432)	14.6 (371)	NPT 1 1/2"

SEG.A20

Power	D	F	Z3	Z4	Z6	Z7	Z9	Z10a	Z11	Z12a	Z15	Z16	Z23	S3OPR	ZDN1
[hp (kW)]	[in. (mm)]														
3.0 (2.6)	4.69 (119)	6.81 (173)	4.53 (115)	7.05 (179)	18.15 (461)	16.18 (411)	2.76 (70)	3/4" - 1"	24.76 (625)	3.15 (80)	3.54 (90)	8.90 (226)	17.4 (442)	15.2 (384)	NPT 2"
4.0 and 5.5 (3.1 and 4.0)	4.69 (119)	6.81 (173)	4.53 (115)	7.05 (179)	18.15 (461)	16.18 (411)	2.76 (70)		26.06 (662)	3.15 (80)	3.54 (90)	8.90 (226)	18.9 (481)	15.2 (384)	NPT 2"

Free-standing installation

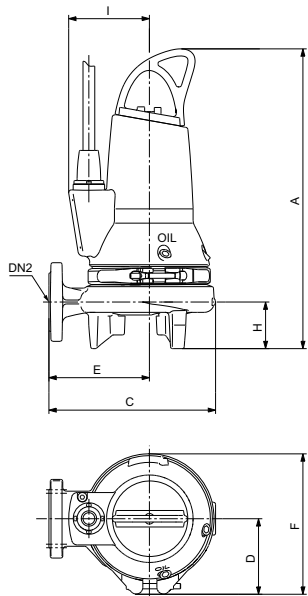

Fig. 15 Free-standing installation

TM06 5742 0116

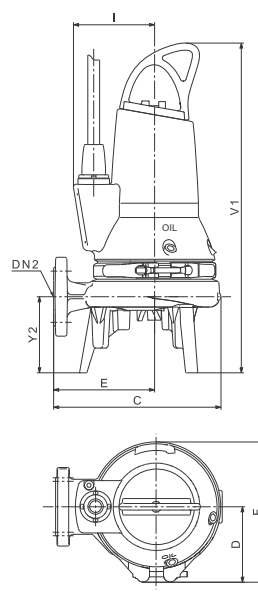

Fig. 16 Free-standing installation with foot extensions

TM06 5745 0116

SEG.A15

Power	A	C	D	DN2	E	F	H	I	V1	Y2
[hp (kW)]	[in. (mm)]				[in. (mm)]					
2.0 (1-phase) (1.5)	18.98 (482)	9.92 (252)	3.9 (99)	1 1/2" (DN 40)	6.06 (154)	8.5 (216)	2.87 (73)	4.84 (123)	20.67 (525)	4.57 (116)
2.0 (3-phase) (1.5)	18.39 (467)	9.92 (252)	3.9 (99)		6.06 (154)	8.5 (216)	2.87 (73)	4.84 (123)	20.08 (510)	4.57 (116)
3.0 (2.6)	20.51 (521)	11.57 (294)	4.69 (119)		6.81 (173)	10.08 (256)	2.36 (60)	5.63 (143)	22.72 (577)	4.53 (115)
4.0 and 5.5 (3.1 and 4.0)	22.09 (561)	11.57 (294)	4.69 (119)		6.81 (173)	10.08 (256)	2.36 (60)	5.63 (143)	24.29 (617)	4.53 (115)

SEG.A20



Power	A	C	D	DN2	E	F	H	I	V1	Y2
[hp (kW)]	[in. (mm)]				[in. (mm)]					
3.0 (2.6)	20.94 (532)	11.54 (293)	4.69 (119)	2" (DN 50)	6.81 (173)	10.08 (256)	2.36 (60)	5.63 (143)	22.72 (577)	4.53 (115)
4.0 and 5.5 (3.1 and 4.0)	22.52 (572)	11.54 (293)	4.69 (119)		6.81 (173)	10.08 (256)	2.36 (60)	5.63 (143)	24.29 (617)	4.53 (115)

Weights

Pumps with A15 outlet flange	Weight [lb (kg)]
SEG.A15.20...	101.4 (46)
SEG.A15.30...	101.4 (46)
SEG.A15.40.2.60H	154.3 (70)
SEG.A15.40.2.60L	105.8 (48)
SEG.A15.40.2.60M	105.8 (48)
SEG.A15.55.2.60H	105.8 (48)
SEG.A15.55.2.60L	154.3 (70)
SEG.A15.55.2.60M	154.3 (70)
Pumps with A20 outlet flange	Weight [lb (kg)]
SEG.A20.30...	178.6 (81)
SEG.A20.40...	178.6 (81)
SEG.A20.55...	178.6 (81)

12. Accessories

Installation systems for SEG pumps

No	Product	Description	Dimensions	Product number	SEG.A15	SEG.A20
1		Auto-coupling system, complete, i.e. upper guide rail bracket, bolts, nuts, gaskets, guide claw and base stand. Cast iron. Note: In installations with guide rails longer than 13 ft (4 m), we recommend that you use an intermediate guide rail bracket.	ANSI 1 1/2" PS (DN 40)	98257507	•	
			ANSI 1 1/2" (DN 40)	98245788	•	
			ANSI 2" (DN 50)	98245790		•
2		Three loose foot extensions to be fitted to the pump housing of free-standing pumps. Stainless steel.	-	96076196	•	•
3		Intermediate guide rail bracket. Guide rails of 13 ft (4 m) and longer. Stainless steel.	-	96887609	•	•
4		Heavy-duty grinder	-	96903344	•	

Other accessories

No	Product	Description	Dimensions	Product number
5		Lifting chain with shackle. With certificates. Stainless steel (ASTM/AISI 316 (EN 1.4571)). Up to 705 lb (320 kg)	6.5 ft (2 m)	98989662
			10 ft (3 m)	98989664
			13 ft (4 m)	98989666
			20 ft (6 m)	98989668
			26 ft (8 m)	98989670
			33 ft (10 m)	98989672

SEG pumps

Level controllers

Grundfos offers a wide range of pump controllers controlling liquid levels in the wastewater collecting tank, ensuring correct operation and protection of the pumps.

Controller ranges:

- Dedicated Controls control cabinets
- SLC and DLC level controllers.
DLC is designed for two-pump installations, and DC can operate up to six pumps in the same pit.

Dedicated Controls

The Grundfos Dedicated Controls system controls and monitors up to six Grundfos wastewater pumps and a mixer or a flush valve.

The Dedicated Controls systems are used in installations requiring advanced control and data communication.

Main components of the Dedicated Controls system:

- CU 362 control unit
- IO 351B module (general I/O module)
- IO 113 interface module between the pump and controller
- SM 113 sensor module.

The Dedicated Controls systems are available either as separate components or as control cabinets, i.e. dedicated controls.

The control system can be operated by the following:

- float switches
- a level sensor
- a level sensor and safety float switches.

The separate control unit and modules can be built for practically any size of system.



Fig. 17 Dedicated Controls control cabinet

TM06 0918 1214

The Dedicated Controls cabinets can be fitted with these units:

- The CU 362 control unit, which is the "brain" of the Dedicated Controls system, is fitted in the cabinet front. The CU 362 can be fitted with one of the Grundfos CIM communication modules mentioned below, depending on the monitoring requirements or the SCADA system:
 - CIM 202: The communication module is used for the Modbus RTU fieldbus protocol.
 - CIM 252: The communication module is used for GSM or GPRS communication. CIM 250 establishes communication between the CU 362 and a SCADA system, allowing the application to be monitored and controlled remotely. This module also offers SMS messaging, for example status and alarm messages.
 - CIM 272: The communication module is used for the Grundfos Remote Management system (GRM). CIM 272 establishes communication between CU 362 and GRM, thereby allowing the application to be monitored and controlled remotely.
- IO 351B, which is a general I/O module. IO 351B communicates with CU 362 via GENIbus.
- MP 204: The motor protector (optional) provides many electrical status values, such as voltage, current, power, insulation resistance and energy. MP 204 offers better protection of the pumps than a conventional motor protection device.
- CUE/VFD (optional), which is either a Grundfos variable frequency converter or a general variable frequency converter, also offers better pump protection and a more steady flow through the pipes. As a result, the pumps are not overloaded, and the energy consumption is kept at a minimum.

For further information, see the data booklet or installation and operating instructions of Dedicated Controls in Grundfos Product Center at www.grundfos.com.

SLC and DLC

The product range of SLC and DLC level controllers comprises models up to 45 A / 15 hp (P2) for direct-on-line starting (DOL).

Features and benefits

- Control of one pump (SLC) or two pumps (DLC)
- automatic alternating operation of two pumps (DLC)
- automatic test run preventing shaft seals from seizing up in the event of long periods of inactivity
- automatic alarm resetting, if required
- automatic restarting, if required
- alarm outputs as NO and NC.



TM05 6609 5012

Fig. 18 DLC and SLC

For further information, see the data booklet or installation and operating instructions on SLC and DLC in Grundfos Product Center at www.grundfos.com.

Name	SLC	DLC
Application		
One pump	•	
Two pumps		•
Battery backup (optional)	•	•
Level sensor		
Analog level sensor with safety float switches	•	•
Starting method		
Direct-on-line starting (DOL)	•	•
Basic functions		
Start and stop of pump(s)	•	•
Pump alternation		•
High-level alarm	•	•

13. Grundfos Product Center

Grundfos Product Center is an online search and sizing tool to help you make the right choice.

<http://product-selection.grundfos.com>



SIZING enables you to size a pump based on entered data and selection choices.

REPLACEMENT enables you to find a replacement product. Search results will include information on

- the lowest purchase price
- the lowest energy consumption
- the lowest total life cycle cost.

The screenshot shows the Grundfos Product Center website. At the top, there is a navigation bar with the Grundfos logo and 'PRODUCT CENTER'. Below this is a search bar with a 'SEARCH' button. The main content area features four large buttons: 'SIZING' (with a subtext 'Enter pump sizing'), 'CATALOG' (with a subtext 'Product and services'), 'REPLACEMENT' (with a subtext 'Replace an old pump with a new'), and 'LIQUIDS' (with a subtext 'Find liquid pump'). Below these buttons is a 'QUICK SIZING' section with input fields for 'Flow (Q)*' and 'Head (H)*', and a 'Select what to size by:' section with radio buttons for 'Size by application', 'Size by pump design', and 'Size by pump family'. A 'START SIZING' button is located to the right of the 'QUICK SIZING' section. At the bottom of the 'QUICK SIZING' section, there are links for 'ADVANCED SIZING: Advanced sizing by application' and 'Guided selection'.

CATALOG gives you access to the Grundfos product catalog.

LIQUIDS enables you to find pumps designed for aggressive, flammable or other special liquids.

All the information you need in one place

Performance curves, technical specifications, pictures, dimensional drawings, motor curves, wiring diagrams, spare parts, service kits, 3D drawings, documents, system parts. The Product Center displays any recent and saved items - including complete projects - right on the main page.

Downloads

On the product pages, you can download installation and Operating Instructions, data booklets, service instructions, etc. in PDF format.

Grundfos GO

Mobile solution for professionals on the GO!

Grundfos GO is the mobile tool box for professional users on the go. It is the most comprehensive platform for mobile pump control and pump selection including sizing, replacement and documentation. It offers intuitive, handheld assistance and access to Grundfos online tools, and it saves valuable time for reporting and data collection.



GET IT ON
Google play



Available on the
App Store

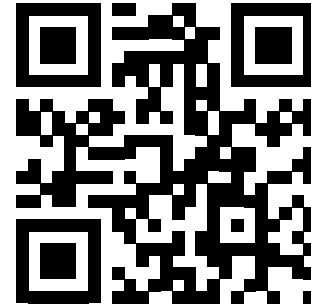

98449275 1018

ECM: 1245922

GRUNDFOS Chicago

3905 Enterprise Court
P.O. Box 6620
Aurora, IL 60598-0620
Phone: +1-630-236-5500
Fax: +1-630-236-5511

GRUNDFOS Kansas City

17100 West 118th Terrace
Olathe, Kansas 66061
Phone: +1-913-227-3400
Fax: +1-913-227-3500
www.grundfos.us

GRUNDFOS Canada

2941 Brighton Road
Oakville, Ontario L6H 6C9 Canada
Phone: +1-905 829 9533
Fax: +1-905 829 9512
www.grundfos.ca

GRUNDFOS México

Boulevard TLC No. 15
Parque Industrial Stiva Aeropuerto
C.P. 66600 Apodaca, N.L. Mexico
Phone: +011-52-81-8144 4000
Fax: +011-52-81-8144 4010
www.grundfos.mx