

SEG

2.0 - 5.5 hp ~ 60 Hz

Installation and operating instructions



Original installation and operating instructions

CONTENTS

	Page
1. Limited warranty	2
2. Symbols used in this document	3
3. General description	3
3.1 Product drawing	3
3.2 Applications	3
3.3 Operating conditions	4
4. Delivery and handling	4
4.1 Transportation	4
4.2 Storage	4
4.3 Lifting	4
5. Identification	5
5.1 Nameplate	5
5.2 Type key	6
6. Approvals	7
6.1 Approval standards	7
6.2 Explanation to FM approval	7
7. Safety	7
7.1 Potentially explosive environments	8
8. Installation	8
8.1 Submerged installation on auto-coupling	9
8.2 Free-standing submerged installation	9
9. Electrical connection	10
9.1 Wiring diagrams	11
9.2 Start and stop levels	11
9.3 Pump controllers	12
9.4 Thermal switches	12
10. Start-up	12
10.1 General start-up procedure	12
10.2 Operating modes	13
10.3 Direction of rotation	13
11. Maintenance and service	14
11.1 Annual maintenance	14
11.2 Oil change	14
11.3 Checking the shaft seal	15
11.4 Adjustment of impeller clearance	15
11.5 Service kits	16
11.6 Contaminated pumps	16
12. Fault finding	17
13. Technical data	18
14. Disposal	18

1. Limited warranty

Products manufactured by GRUNDFOS PUMPS CORPORATION (Grundfos) are warranted to the original user only to be free of defects in material and workmanship for a period of 24 months from date of installation, but not more than 30 months from date of manufacture. Grundfos liability under this warranty shall be limited to repairing or replacing at Grundfos option, without charge, F.O.B. Grundfos factory or authorized service station, any product of Grundfos manufacture. Grundfos will not be liable for any costs of removal, installation, transportation, or any other charges which may arise in connection with a warranty claim. Products which are sold but not manufactured by Grundfos are subject to the warranty provided by the manufacturer of said products and not by Grundfos warranty. Grundfos will not be liable for damage or wear to products caused by abnormal operating conditions, accident, abuse, misuse, unauthorized alteration or repair, or if the product was not installed in accordance with Grundfos printed installation and operating instructions.

To obtain service under this warranty, the defective product must be returned to the distributor or dealer of Grundfos products from which it was purchased together with proof of purchase and installation date, failure date, and supporting installation data. Unless otherwise provided, the distributor or dealer will contact Grundfos or an authorized service station for instructions. Any defective product to be returned to Grundfos or a service station must be sent freight prepaid; documentation supporting the warranty claim and/or a Return Material Authorization must be included if so instructed.

GRUNDFOS WILL NOT BE LIABLE FOR ANY INCIDENTAL OR CONSEQUENTIAL DAMAGES, LOSSES, OR EXPENSES ARISING FROM INSTALLATION, USE, OR ANY OTHER CAUSES. THERE ARE NO EXPRESS OR IMPLIED WARRANTIES, INCLUDING MERCHANTABILITY OR FITNESS FOR A PARTICULAR PURPOSE, WHICH EXTEND BEYOND THOSE WARRANTIES DESCRIBED OR REFERRED TO ABOVE.

Some jurisdictions do not allow the exclusion or limitation of incidental or consequential damages and some jurisdictions do not allow limit actions on how long implied warranties may last. Therefore, the above limitations or exclusions may not apply to you. This warranty gives you specific legal rights and you may also have other rights which vary from jurisdiction to jurisdiction.

**Warning**

Prior to installation, read these installation and operating instructions. Installation and operation must comply with local regulations and accepted codes of good practice.

**Warning**

The use of this product requires experience with and knowledge of the product.

Persons with reduced physical, sensory or mental capabilities must not use this product, unless they are under supervision or have been instructed in the use of the product by a person responsible for their safety.

Children must not use or play with this product.

2. Symbols used in this document



Warning
If these safety instructions are not observed, it may result in personal injury.



Warning
If these instructions are not observed, it may lead to electric shock with consequent risk of serious personal injury or death.



Warning
These instructions must be observed for explosion-proof pumps. It is advisable also to follow these instructions for standard pumps.

Caution If these safety instructions are not observed, it may result in malfunction or damage to the equipment.

Note Notes or instructions that make the job easier and ensure safe operation.

3. General description

Note Notes or instructions that make the job easier and ensure safe operation.

Grundfos SEG pumps are designed with a grinder system which grinds solid particles into small pieces so that they can be led away through pipes of a relatively small diameter.

SEG pumps are used in pressurized systems, e.g. in hilly areas.

The pumps can be controlled via the Grundfos control box with motor-protective circuit breaker.

See installation and operating instructions for the selected unit.

3.1 Product drawing

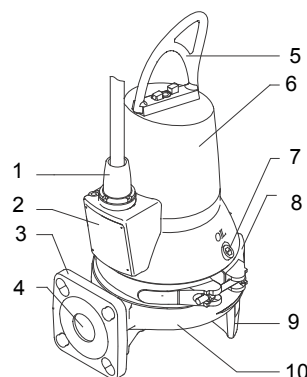

Fig. 1 SEG pump

Pos.	Designation
1	Cable plug
2	Nameplate
3	Outlet flange ANSI 1 1/2" or 2" (DN 40 or DN 50)
4	Outlet port
5	Lifting bracket
6	Stator housing
7	Oil screw
8	Clamp
9	Pump foot
10	Pump housing

3.2 Applications

SEG pumps are designed for pumping the following liquids:

- domestic wastewater with discharge from water closets
- sewage from restaurants, hotels, camping sites, etc.

The compact design makes the pumps suitable for both temporary and permanent installation. The pumps can be installed on an auto-coupling system or stand freely on the bottom of the pit.

TM06 57 40 0316

3.3 Operating conditions

The Grundfos SEG range are designed for intermittent operation (S3). When completely submerged, the pumps can also run continuously (S1). See section [10.2 Operating modes](#).

Installation depth

Maximum 38 ft (10 m) below liquid level.

Operating pressure

Maximum 87 PSI (6 bar).

Number of starts per hour

Maximum 30.

pH value

Pumps in permanent installations can cope with pH values ranging from 4 to 10.

Liquid temperature

32-104 °F (0-40 °C).

For short periods (maximum 15 minutes), a temperature of up to 140 °F (60 °C) is permissible (non-Ex versions only).



Warning

Explosion-proof pumps must never pump liquids with a temperature higher than 104 °F (40 °C).

For single-phase pumps, 2 hp (1.5 kW), working at 10 % overvoltage, pumping 104 °F (40 °C) liquid, the maximum continuous operating time is six minutes. If the six minutes are exceeded, the thermal switch inside the motor windings might be activated and cause the pump to stop.

Note

Density and viscosity of pumped liquid

When pumping liquids with a density and/or a kinematic viscosity higher than that of water, use motors with correspondingly higher outputs.

4. Delivery and handling

The pump may be transported and stored in a vertical or horizontal position. Make sure that it cannot roll or fall over.

4.1 Transportation

All lifting equipment must be rated for the purpose and checked for damage before any attempts to lift the pump. The lifting equipment rating must under no circumstances be exceeded. The pump weight is stated on the nameplate.



Warning

Always lift the pump by its lifting bracket or by means of a fork-lift truck if the pump is fixed on a pallet. Never lift the pump by means of the motor cable or the hose or pipe.

The polyurethane-embedded plug prevents water from penetrating into the motor via the motor cable.

4.2 Storage

For long periods of storage, the pump must be protected against moisture and heat.

After a long period of storage, the pump must be inspected before it is put into operation. Make sure that the impeller can rotate freely. Pay special attention to the shaft seals and the cable entry.

4.3 Lifting

When lifting the pump, use the right lifting point in order to keep the pump balanced. Place the lifting chain hook in point A for auto-coupling installations and in point B for other installations. See fig. 2.

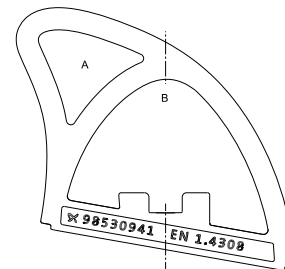

Fig. 2 Lifting points

TM06 0066 4813

5. Identification

5.1 Nameplate

The nameplate states the operating data and approvals applying to the pump. The nameplate is fixed with rivets to the side of the stator housing near the cable input to the motor.

Fix the additional nameplate supplied with the pump close to the pit.

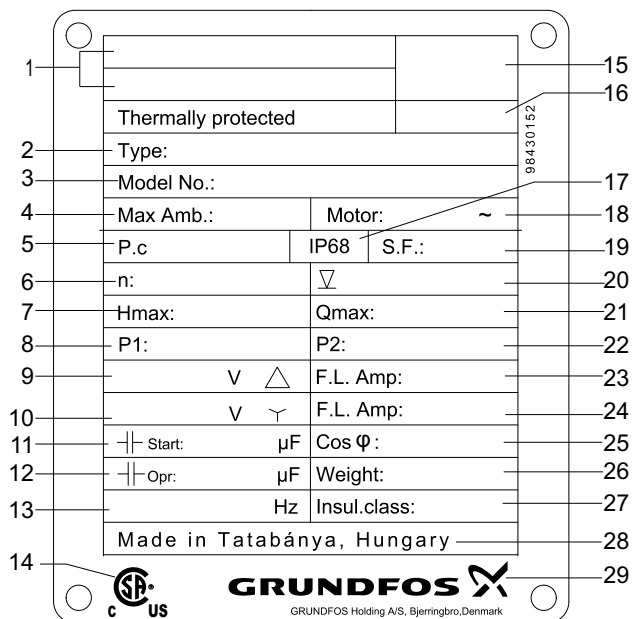

Fig. 3 SEG nameplate

Pos.	Description
1	FM description
2	Type designation
3	Product number + serial number
4	Maximum liquid temperature
5	Production code (YYWW)
6	Speed [rpm]
7	Maximum head [ft]
8	Rated power input [hp]
9	Rated voltage, Δ
10	Rated voltage, Y
11	Starting capacitor [μ F]
12	Run capacitor [μ F]
13	Frequency [Hz]
14	Electrical safety*
15	Approvals

* For USA and Canada

Pos.	Description
16	Mark for continuously operated motor
17	Enclosure class
18	Phases
19	Service factor
20	Maximum installation depth [ft]
21	Maximum flow rate [US gpm]
22	Rated power output [hp]
23	Rated current, Δ
24	Rated current, Y
25	Cos ϕ , 1/1 load
26	Net weight [lbs]
27	Insulation class
28	Production country
29	Grundfos logo

TM06 5866 0216

5.2 Type key

The type key covers the entire Grundfos SEG range of wastewater pumps. This is why the type key has a number of empty fields for the grinder pumps. Each SEG grinder pump is identified by means of the type key below. Please note that not all combination options are available.

Code	Example	SE	G	.A15	.20	.R2	.2	.1	6	03
SE	Type range Grundfos sewage pumps									
G	Impeller type Grinder system in the pump inlet									
A15	Pump outlet Nominal diameter of pump outlet port = code type for type designation / 10 [inch] 1.5" (40 mm)									
A20	2.0" (50 mm)									
	Output power, P2 P2 = Code number from type designation / 10 [hp]									
[]	Impeller diameter Standard									
R1	4" (98 mm)									
R2	3.5" (89 mm)									
[]	Pump version Non-explosion-proof, CSA-approved									
Ex	Explosion-proof motor, CSA and FM approved									
2	Number of poles 2-pole motor									
1	Number of phases Single-phase motor									
[]	Three-phase motor									
6	Mains frequency 60 Hz									
03	Voltage and starting method (DOL) 208-230 V									
0M	200-230 V									
0H	460 V									
0L	575 V									

6. Approvals

The standard versions of SEG 60 Hz pumps have been approved by CSA and the explosion-proof version holds a CSA and FM type examination certificate no.: 3053414 (USA), 3053414C (Canada).

6.1 Approval standards

CSA approval according to UL778 and C22.2 No. 108, No. 0.4, No. 30, No. 145 and No. 60529. FM approval according to FM 3600, FM 3615 and FM 3650 and ANSI/IEC 60529.

6.2 Explanation to FM approval

The SEG 60 Hz pumps have the following explosion protection classification: Class I, Division 1, Groups C and D hazardous locations, T3C, IP68.

Standards	Code	Description
FM 3600 FM 3615 FM 3650 ANSI/IEC 60529	Class I	Explosive atmosphere caused by gases or vapors (permitted class)
	Division 1	Area classification (permitted division)
	Group C and D	Classification of gases
	T3C	Maximum surface temperature is 275 °F and 320 °F (135 °C and 160 °C)
	IP68	Enclosure class according to IEC 60529.

7. Safety



Warning

Pump installation in pits must be carried out by specially trained persons.

Work in or near pits must be carried out according to local regulations.



Warning

Persons must not enter the installation area when the atmosphere is explosive.



Warning

It must be possible to lock the mains switch in position 0. Type and requirements as specified in local regulations.



Warning

The use of this product requires experience with and knowledge of the product.

Persons with reduced physical, sensory or mental capabilities must not use this product, unless they are under supervision or have been instructed in the use of the product by a person responsible for their safety.

Children must not use or play with this product.

For safety reasons, all work in pits must be supervised by a person outside the pump pit.

Note

It is advisable to make all maintenance and service work when the pump is placed outside the pit.

Pits for submersible wastewater pumps contain wastewater with toxic and/or disease-causing substances. Therefore, all persons involved must wear appropriate personal protective equipment and clothing and all work on and near the pump must be carried out under strict observance of the hygiene regulations in force.



Warning

Make sure that the lifting bracket is tightened before attempting to lift the pump. Tighten if necessary. Carelessness during lifting or transportation may cause injury to personnel or damage to the pump.

The following warnings and notes also appear in a label (delivered with the pump). Place the label near the control panel.



Warning

Risk of electric shock.

Do not remove cord and strain relief. Do not connect conduit to pump.



Warning

Risk of electric shock.

This pump has not been approved for use in swimming pools or marine areas.



Warning

To reduce risk of electric shock, see installation and operating instructions for guidance in proper installation.



Warning

To reduce risk of electric shock, install only on a circuit protected by a ground-fault circuit interrupter (GFCI).

Note

Acceptable for indoor and outdoor use.

Note

Submersible pump.

Caution

Provide suitable motor protection based on the electric ratings.

Caution

This pump has been tested with water only.

Caution

Use with approved motor protective circuit breaker matching motor input in full-load amperes with overload element(s) selected or adjusted in accordance with control instructions.

7.1 Potentially explosive environments

Use explosion-proof SEG pumps for applications in potentially explosive environments.



Warning
SEG pumps must under no circumstances pump flammable, combustible or explosive liquids.



Warning
The classification of the installation site must be approved by the local firefighting authorities in each individual case.

Warning
Special conditions for safe use of SEG explosion-proof pumps:

1. Make sure the moisture switches and thermal switches are connected in the same circuit but have separate alarm outputs (motor stop) in case of high humidity or high temperature in the motor.
2. Bolts used for replacement must be class A2-70 or better according to EN/ISO 3506-1.
3. Contact the manufacturer for information on the dimensions of the flameproof joints.
4. The level of pumped liquid must be controlled by two stop level switches connected to the motor control circuit. The minimum level depends on the installation type and is specified in these installation and operating instructions.
5. Make sure the permanently attached cable is suitably mechanically protected and terminated in a suitable terminal board placed outside the potentially explosive area.
6. Sewage pumps have an ambient temperature range of -32 °F (0 °C) to 104 °F (40 °C) and a maximum process temperature of 104 °F (40 °C).
7. The thermal protection in the stator windings has a nominal switch temperature of 302 °F (150 °C) and must guarantee the disconnection of the power supply; the power supply must be reset manually.



8. Installation

Caution

Prior to installation, make sure the pit bottom is even.



Warning
Before beginning the installation, switch off the power supply and lock the mains switch in position 0. Any external voltage connected to the pump must be switched off before working on the pump.



Warning
Before installation and the first start-up of the pump, check the cable for visible defects to avoid short-circuits.

Fit the extra nameplate supplied with the pump at the installation site or keep it in the cover of this booklet.

All safety regulations must be observed at the installation site, e.g. the use of blowers for fresh-air supply to the pit.

Prior to installation, check the oil level in the oil chamber. See section [11. Maintenance and service](#).

The SEG pumps are suitable for different installation types which are described in sections [8.1 Submerged installation on auto-coupling](#) and [8.2 Free-standing submerged installation](#).

All pump housings have a cast ANSI 1 1/2" (DN 40), PN 10, or 2" (DN 50), PN10, outlet flange.

Note

The pumps are designed for intermittent operation. When completely submerged in the pumped liquid, the pumps can also run continuously. See section [13. Technical data](#).



Warning
Do not put your hands or any tool into the pump inlet or outlet port after the pump has been connected to the power supply, unless the pump has been switched off by removing the fuses or switching off the mains switch. Make sure that the power supply cannot be accidentally switched on.

Caution

We recommend that you always use Grundfos accessories to avoid malfunctions due to incorrect installation.



Warning
Only use the lifting bracket for lifting the pump. Do not use it to hold the pump when in operation.

8.1 Submerged installation on auto-coupling

Pumps for permanent installation can be mounted on a stationary auto-coupling guide rail system.

The auto-coupling systems facilitate maintenance and service as the pump can easily be lifted out of the pit.



Warning

Before beginning installation procedures, make sure that the atmosphere in the pit is not potentially explosive.

Make sure that the pipework is installed without the use of undue force. No loads from the pipework weight must be carried by the pump. We recommend that you use loose flanges to ease the installation and to avoid pipe tension at flanges and bolts.

Note

Do not use elastic elements or bellows in the pipework; these elements must never be used as a means to align the pipework.

Note

Auto-coupling guide rail system

See fig. 1 on page 19.

1. Drill mounting holes for the guide rail bracket on the inside of the pit and fasten the guide rail bracket provisionally with two screws.
2. Place the auto-coupling base unit on the bottom of the pit. Use a plumb line to establish the correct positioning. Fasten the auto-coupling with heavy-duty expansion bolts. If the bottom of the pit is uneven, the auto-coupling base unit must be supported so that it is level when being fastened.
3. Assemble the outlet pipe in accordance with the generally accepted procedures and without exposing the it to distortion or tension.
4. Insert the guide rails in the auto-coupling base unit and adjust the length of the rails accurately to the guide rail bracket.
5. Unscrew the provisionally fastened guide rail bracket, fit it on top of the guide rails, and finally fasten it firmly to the pit wall.

Note

The guide rails must not have any axial play as this would cause noise during pump operation.

6. Clean out debris from the pit before lowering the pump into the pit.
7. Fit the guide claw to the outlet port of the pump.
8. Slide the guide claw down the guide rails and lower the pump into the pit by means of a chain fastened to the lifting bracket. When the pump reaches the auto-coupling base unit, the pump will automatically connect tightly.
9. Hang up the end of the chain on a suitable hook at the top of the pit and in such a way that the chain cannot come into contact with the pump housing.
10. Adjust the length of the motor cable by coiling it up on a relief fitting to ensure that the cable is not damaged during operation. Fasten the relief fitting to a suitable hook at the top of the pit. Make sure that the cables are not sharply bent or pinched.
11. Connect the motor cable and the monitoring cable, if any.

Caution

The free end of the cable must not be submerged as water may penetrate through the cable into the motor.

8.2 Free-standing submerged installation

Pumps for free-standing submerged installation can stand freely on the bottom of the pit or the like. See fig. 2 on page 20.

The pump can be mounted on separate feet (accessory).

In order to facilitate service on the pump, fit a flexible union or coupling to the outlet pipe for easy separation.

If a hose is used, make sure that the hose does not buckle and that the inside diameter matches that of the outlet port.

If a rigid pipe is used, the union or coupling, non-return valve and isolating valve must be fitted in the order mentioned, when viewed from the pump.

If the pump is installed in muddy conditions or on uneven ground, we recommend that you support the pump on bricks or a similar support.

1. Fit a 90 ° elbow to the pump outlet port and connect the outlet pipe/hose.
2. Lower the pump into the liquid by means of a chain secured to the lifting bracket of the pump. We recommended that you place the pump on a plane, solid foundation. Make sure that the pump is hanging from the chain and not the cable.
3. Hang up the end of the chain on a suitable hook at the top of the pit and in such a way that the chain cannot come into contact with the pump housing.
4. Adjust the length of the motor cable by coiling it up on a relief fitting to ensure that the cable is not damaged during operation. Fasten the relief fitting to a suitable hook. Make sure that the cables are not sharply bent or pinched.
5. Connect the motor cable and the monitoring cable, if any.

Caution

The free end of the cable must not be submerged as water may penetrate through the cable into the motor.

Note

If several pumps are to be installed in the same pit, the pumps must be installed at the same level in order to allow for optimum utilization of pump alternation.

9. Electrical connection

Warning

Connect the pump to an external mains switch which ensures all-pole disconnection with a contact separation according to EN 60204-1, 5.3.2.



It must be possible to lock the mains switch in position 0.

Type and requirements as specified in EN 60204-1, 5.3.2.

The electrical connection must be carried out in accordance with local regulations.

Warning

The pumps must be connected to a control box with a motor protection relay with an IEC trip class 10 or 15.



Warning

The permanent installation must be fitted with ground fault circuit interrupter (GFCI) with a tripping current < 30 mA.



Warning

Pumps installed in hazardous locations must be connected to a control box with a motor protection relay with an IEC trip class 10.



Warning

Do not install Grundfos control boxes, pump controllers, Ex barriers and the free end of the supply cable in potentially explosive environments. The classification of the installation site must be approved by the local firefighting authorities in each individual case.

On explosion-proof pumps, make sure that an external earth lead is connected to the external earth terminal of the pump via a lead with a secure cable clamp. Clean the surface for external earth connection and fit the cable clamp.

The cross-section of the earth conductor must be at least 4 mm², e.g. type H07 V2-K (PVT 90 °) yellow/green. Make sure that the earth connection is protected from corrosion. Make sure that all protective equipment has been connected correctly. Float switches used in potentially explosive environments must be approved for this application. They must be connected to the Grundfos SLC, DLC controller via the intrinsically safe LC-Ex4 barrier to ensure a safe circuit.



Warning

If the supply cable is damaged, it must be replaced by the manufacturer, its service agent or similarly qualified persons.



Caution

Set the motor-protective circuit breaker to the rated current of the pump. The rated current is stated on the pump nameplate.

Warning

If the pump has an FM mark on the nameplate, make sure that the pump is connected in accordance with the instructions given in this booklet.



The supply voltage and frequency are marked on the pump nameplate. The permissible voltage tolerance is - 10 %/+ 6 % of the rated voltage. Make sure that the motor is suitable for the power supply available at the installation site.

All pumps are supplied with 33 ft (10 m) of cable and a free cable end.

All pumps are supplied without a control box.

- The pump must be connected to a control box with motor-protective circuit breaker.

See fig. 4 or 5 and the installation and operating instructions for the selected control box or pump controller.

Potentially explosive environments

In potentially explosive environments you have one option:

- Use float switches made for Ex environment and a safety barrier in combination with either DC, DCD or LC, LCD 108.

Warning

Before installation and the first start-up of the pump, check the condition of the cable visually to avoid short circuits.



For more information about the function of the thermal switches, see section [9.4 Thermal switches](#).

9.1 Wiring diagrams

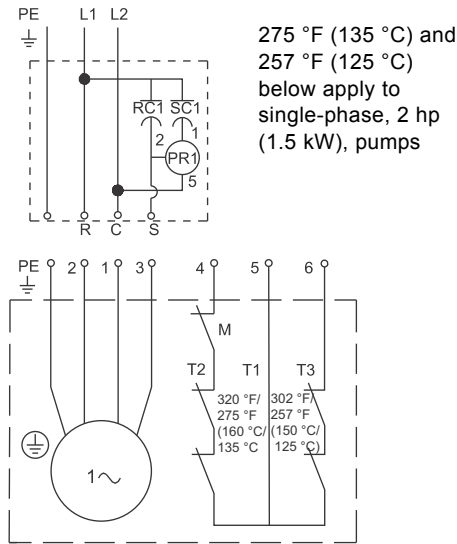

Wire no.	Type	Connection
1	Common (C)	U1 / Z1
2	Run (R)	U2
3	Start (S)	Z2

Fig. 4 Wiring diagram for single-phase pumps

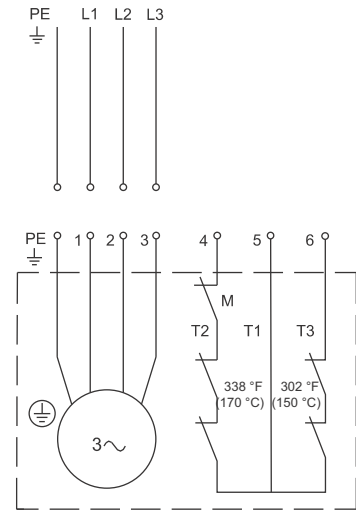

Fig. 5 Wiring diagram for three-phase pumps

9.2 Start and stop levels

The difference in level between start and stop can be adjusted by means of the installed level detecting equipment.

Note Both the two following points must be observed.

- To prevent air intake and vibrations, install the stop level switch in such a way that the pump is stopped before the liquid level is lowered below the upper edge of the clamp on the pump.
- Install the start level switch in such a way that the pump is started at the required level; however, the pump must always be started before the liquid level reaches the bottom inlet pipe to the pit.

The pump must not run dry. Install an additional level switch to ensure that the pump is stopped in case the stop level switch is not operating. Stop the pump when the liquid level reaches the upper edge of the clamp on the pump. Float switches used in explosive environments must be approved for this application. They must be connected to a controller via the intrinsically safe LC-Ex4 barrier to ensure a safe circuit.



Warning



Install an additional level switch to ensure that the pump is stopped in case the stop level switch is not operating. See fig. 6.

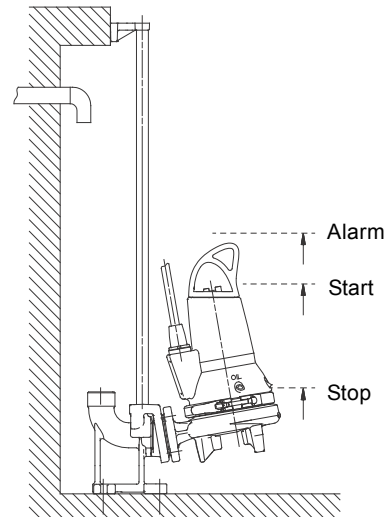

Fig. 6 Start and stop levels

TM06 5693 0316

TM06 5694 0316

TM06 5741 0316

9.3 Pump controllers

Controllers incorporating motor protection relay and control unit are available from Grundfos:

When installing the level switches, observe the following points:

- To prevent air intake and vibrations, install the stop level switch in such a way that the pump is stopped before the liquid level is lowered below the middle of the motor housing.
- Install the start level switch in such a way that the pump is started at the required level; however, the pump must always be started before the liquid level reaches the bottom inlet pipe to the pit.
- The high-level alarm switch, if installed, must always be installed about 4 inches (10 cm) above the start level switch; however, the alarm must always be given before the liquid level reaches the inlet pipe to the pit.

For further settings, see the installation and operating instructions for the pump controller selected.

9.4 Thermal switches

All SEG pumps have two sets of thermal switches incorporated in the stator windings.

The thermal switch in circuit 1 (T1-T3) will break the circuit at a winding temperature of approx. 302 °F (150 °C).

In single-phase, 2 hp (1.5 kW) pumps, the thermal switch will break the circuit at a winding temperature of approx. 257 °F (125 °C).

Warning



After thermal cutout, explosion-proof pumps must be restarted manually. The thermal switch (circuit 2) must be connected for manual restarting of these pumps.

Note

This thermal switch must be connected for all pumps.

The maximum operating current of the thermal switches is 0.5 A at 500 VAC and $\cos \varphi$ 0.6. The switches must be able to break a coil in the supply circuit.

In the case of standard pumps, both thermal switches can, when closing the circuit after cooling, generate automatic restarting of the pump via the controller.

Warning



The separate motor-protective circuit breaker or control box must not be installed in potentially explosive environments.

10. Start-up

Warning



Before starting work on the pump, make sure that the fuses have been removed or the mains switch has been switched off. Make sure that the power supply cannot be accidentally switched on.

Make sure that all protective equipment has been connected correctly.

The pump must not run dry.

Warning



Only Ex pumps must be started if the atmosphere in the pit is potentially explosive.

Warning



It may lead to personal injuries or death to open the clamp while the pump is operating.

10.1 General start-up procedure

Proceed as follows:

1. Remove the fuses, and check whether the impeller can rotate freely. Turn the grinder head by hand.
2. Check the condition of the oil in the oil chamber. See also section [11.2 Oil change](#).
3. Check whether the monitoring units, if used, are operating satisfactorily.
4. Check the setting of the float switches.
5. Open the isolating valves, if fitted.
6. Lower the pump into the liquid and insert the fuses.
7. Check whether the system has been filled with liquid and vented. The pump is self-venting.
8. Start the pump.

In case of abnormal noise or vibrations from the pump, other pump failure or power supply failure, stop the pump immediately. Do not attempt to restart the pump until the cause of the fault has been found and the fault corrected.

Caution

Check the condition of the oil in the chamber after one week of operation after replacement of the shaft seal. See section [11. Maintenance and service](#).

10.2 Operating modes

The pumps are designed for intermittent operation (S3). When completely submerged, the pumps can also run continuously (S1).

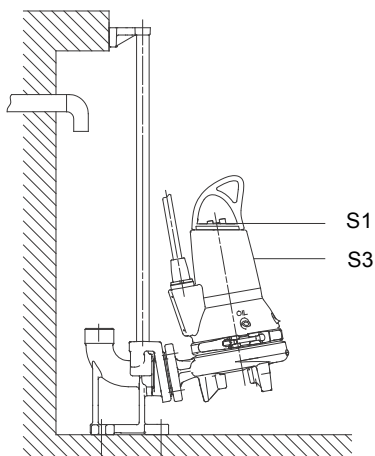

Fig. 7 Operating levels

S3, intermittent operation

S3 operation is a series of identical duty cycles (TC) each with a constant load for a period, followed by a rest period. Thermal equilibrium is not reached during the cycle. See fig. 8. In this operating mode, the pump is partly submerged in the pumped liquid, i.e. the liquid level reaches at least the middle of the motor. See fig. 7.

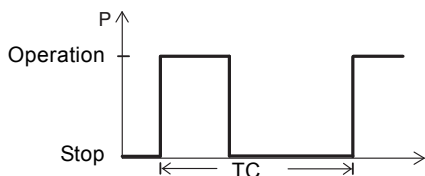

Fig. 8 S3 operation

S1, continuous operation

In this operating mode, the pump can run continuously without having to be stopped for cooling. Being completely submerged, the pump is sufficiently cooled by the surrounding liquid. See fig. 9.

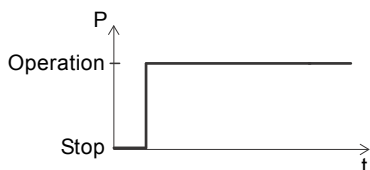

Fig. 9 S1 operation

10.3 Direction of rotation

Note

The pump may be started for a very short period without being submerged to check the direction of rotation.

All single-phase pumps are factory-wired for the correct direction of rotation.

Before starting up three-phase pumps, check the direction of rotation.

An arrow on the stator housing and an arrow at the pump inlet indicate the correct direction of rotation.

Correct direction of rotation is clockwise when viewed from above. When started, the pump will jerk in the opposite direction of the direction of rotation.

If the direction of rotation is wrong, interchange two phases. See fig. 4 or 5.

Checking the direction of rotation

Check the direction of rotation in one of the following ways every time the pump is connected to a new installation.

Procedure 1

1. Start the pump and measure the quantity of liquid or the outlet pressure.
2. Stop the pump and interchange two phases.
3. Restart the pump and measure the quantity of liquid or the outlet pressure.
4. Stop the pump.
5. Compare the results taken under points 1 and 3. The connection which gives the larger quantity of liquid or the higher pressure is the correct direction of rotation.

Procedure 2

1. Let the pump hang from a lifting device, e.g. the hoist used for lowering the pump into the pit.
2. Start and stop the pump while observing the movement (jerk) of the pump.
3. If connected correctly, the pump will jerk in the opposite direction of the direction of rotation. See fig. 10.
4. If the direction of rotation is wrong, interchange two phases. See fig. 4 or 5.

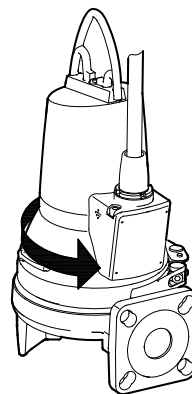

Fig. 10 Jerk direction

TM06 5749 0316

TM04 9231 3710

TM04 4528 1509

TM02 5393 2802

11. Maintenance and service



Warning

Before starting work on the pump, make sure that the fuses have been removed or the mains switch has been switched off. Make sure that the power supply cannot be accidentally switched on.

All rotating parts must have stopped moving.



Warning

Except for service on the pump parts, all other service work must be carried out by Grundfos or a service workshop authorized by Grundfos.

Flush the pump thoroughly with clean water before maintenance and service. Rinse the pump parts in water after dismantling.



Warning

When loosening the screws of the oil chamber, note that pressure may have built up in the chamber. Do not remove the screws until the pressure has been fully relieved.

11.1 Annual maintenance

Pumps running normal operation must be checked every 3000 operating hours or at least once a year. If the dry solids content of the pumped liquid is very high or sandy, check the pump at shorter intervals.

Check the following points:

- **Power consumption**
See section [5.1 Nameplate](#).
- **Motor oil level and oil condition**
Check the condition of the oil and replace oil and shaft seal if oil is contaminated. After replacement of the shaft seal, check the oil level after one week of operation.
Use Shell Ondina X420 oil or similar type. See sections [11.2 Oil change](#).

Note

Used oil must be disposed of in accordance with local regulations.

- **Cable entry**
Make sure that the cable entry is watertight and that the cables are not sharply bent and/or pinched. See section [11.5 Service kits](#).

Note

A possible replacement of the cable must be carried out by Grundfos or a service workshop authorized by Grundfos.

- **Pump parts**
Check the impeller, pump housing, etc. for possible wear. Replace defective parts. See section [11.5 Service kits](#).
- **Ball bearings**
Check the shaft for noisy or heavy operation (turn the shaft by hand). Replace defective ball bearings.
- **Grinder system or parts**
In case of frequent choke-ups, check the grinder system for wear. When worn, the edges of the grinding parts are round and worn. Compare with a new grinder system.

11.2 Oil change



Warning

When loosening the screws of the oil chamber, note that pressure may have built up in the chamber. Do not remove the screws until the pressure has been fully relieved.

Motor oil quantities

The table states the quantity of oil in the oil chamber of SEG pumps:

Pump type	Oil in oil chamber [oz (l)]
2.0 hp (1.5 kW)	6.0 (0.17)
3.0 to 5.5 hp (2.6 to 4.0 kW)	15.0 (0.42)

Draining of oil

1. Loosen and remove both oil screws to allow all the oil to drain from the chamber.
2. Check the oil for water and impurities. If the shaft seal has been removed, the oil will give a good indication of the condition of the shaft seal.

Note

Used oil must be disposed of in accordance with local regulations.

Filling with oil

Pump in horizontal position:

1. Place the pump in such a position that it is lying on the stator housing and the outlet flange and so that the oil screws are pointing upwards. See [fig. 11](#).
2. Fill oil into the oil chamber through the upper hole until it starts running out of the lower hole. The oil level is now correct.
3. Fit both oil screws using the packing material included in the kit. See section [11.5 Service kits](#).

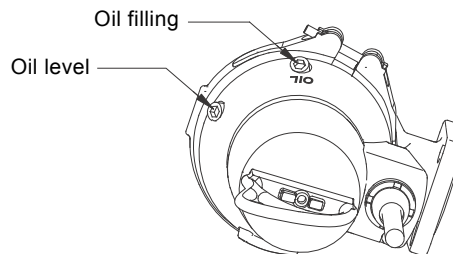

Fig. 11 Oil filling holes

Pump in vertical position:

1. Place the pump in upright position on a plane, horizontal surface.
2. Fill oil into the oil chamber through one of the holes until it starts running out of the other hole. For oil quality, see the table above.
3. Fit both oil screws using the packing material included in the kit. See section [11.5 Service kits](#).

11.3 Checking the shaft seal

Check the oil to make sure that the shaft seal is intact.

If the oil is greyish white like milk or contains a large quantity of water, the shaft seal must be replaced as the primary part of the seal is worn. If the seal is still used, the motor will be damaged within a short time.

If the oil is clean, it can be reused.

11.4 Adjustment of impeller clearance



Warning

Before inspection, make sure that the motor is switched off and that the mains switch is locked in position 0.

To adjust impeller, you need to dismantle the grinder system first:

1. See section [11.2 Oil change](#).
2. Place the pump on horizontal position on a table.
3. Remove the screw (188a) from the pump feet.
4. Loosen the grinder ring (44) by knocking it clockwise with a punch. See [fig. 12](#).

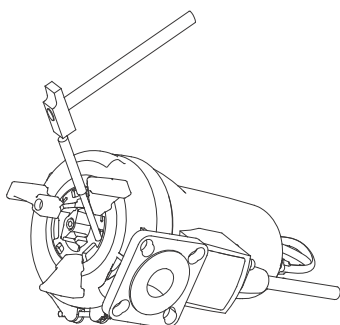

TM06 5746 0316

Fig. 12 Dismantling the grinder ring

5. Remove the grinder ring (44).
6. Insert the punch into the hole to hold the impeller to prevent it from moving during dismantling.
7. Remove the screw (188a) including lock washer (66) from the shaft end. See [fig. 13](#).
8. Remove the grinder head (45).

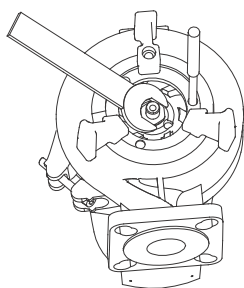

TM06 5747 0316

Fig. 13 Dismantling the screw and grinder head

9. Tighten the adjusting nut (68) until the impeller (49) cannot rotate any more.
10. Loosen the adjusting nut (68) by 1/4 turn.

Assembly of grinder system:

1. Fit the grinder head (45). The dogs on the back of the grinder head must engage with the impeller holes (49).
2. Tighten the screw (188a) in the shaft end to torque of 20 Nm \pm 2. Do not forget the lock washer.
3. Fit the grinder ring (44) and turn it 15 to 20 ° anti-clockwise until it is tightened.
4. Check that the grinder ring does not touch the grinder head.
5. Tighten the screw (188a) to torque of 16 Nm \pm 2.
6. Check that the grinder head can rotate freely and noiselessly.

11.5 Service kits



Warning

Before starting work on the pump, make sure that the fuses have been removed or the mains switch has been switched off. Make sure that the power supply cannot be accidentally switched on.

All rotating parts must have stopped moving.

The following service kits are available for all SEG 60 Hz pumps and can be ordered as required:

Service kit	Description	Pump type	Material	Product number
Shaft seal kit	Shaft seal complete	SEG.A15	BQQP	96076122
			BQQV	96645160
		SEG.A20	BQQP	96076123
			BQQV	96645275
O-ring kit	O-rings and gaskets for oil screws	SEG.A15	NBR	96076124
			FKM	96646061
		SEG.A20	NBR	96076125
			FKM	96646062
Grinder system	Grinder head, grinder ring, shaft screw and locking screw	SEG.A15 (DN 40)	Standard	96076121
		SEG.A15 (DN 40)	Heavy duty	96903344
		SEG.A20 (DN 50) High flow	-	98453210
		SEG.A15.20.R1	-	98453203
		SEG.A15.20.R2	-	98453205
		SEG.A15.20	-	98453192
Impeller	Impeller complete with adjusting nut, shaft screw and key	SEG.A15.30	-	98453178
		SEG.A15.40	-	98453177
		SEG.A20.50	-	98453172
		SEG.A20.50	-	98453172
Oil	33.8 oz (1 liter) of oil, type Shell Ondina X420. See section 11.2 Oil change for required quantity in oil chamber.	All types	-	96586753

Note

A possible replacement of the cable must be carried out by Grundfos or a service workshop authorized by Grundfos.

11.6 Contaminated pumps



Warning

If a pump has been used for a liquid which is injurious to health or toxic, the pump will be classified as contaminated.

If you request Grundfos to service the pump, contact Grundfos with details about the pumped liquid, etc. before returning the pump for service. Otherwise Grundfos can refuse to accept the pump for service.

Possible costs of returning the pump are paid by the customer.

However, any application for service (no matter to whom it may be made) must include details about the pumped liquid if the pump has been used for liquids which are injurious to health or toxic.

The pump must be cleaned in the best possible way before a pump is returned.

12. Fault finding



Warning

All regulations applying to pumps installed in potentially explosive environments must be observed. Make sure that no work is carried out in potentially explosive atmosphere.



Warning

Before attempting to diagnose any fault, make sure that the fuses have been removed or the mains switch has been switched off. Make sure that the power supply cannot be accidentally switched on. All rotating parts must have stopped moving.

Fault	Cause	Remedy
1. The motor does not start. The fuses blow, or the motor-protective circuit breaker trips immediately. Caution: Do not start again!	a) Supply failure; short-circuit; earth-leakage fault in the cable or the motor winding.	Have the cable and the motor checked and repaired by a qualified electrician.
	b) Wrong type of fuse.	Install fuses of the correct type.
	c) The impeller is blocked by impurities.	Clean the impeller.
	d) The float switch is out of adjustment or defective.	Check the float switches.
2. The pump runs, but the motor-protective circuit breaker trips after a short while.	a) Low setting of the thermal relay in the motor-protective circuit breaker.	Set the relay in accordance with the specifications on the nameplate.
	b) Increased current consumption due to large voltage drop.	Measure the voltage between two motor phases. Tolerance: - 10 %/+ 6 %.
	c) The impeller is blocked by impurities. Increased current consumption in all three phases.	Clean the impeller.
	d) Adjustment of the impeller clearance incorrect.	Readjust the impeller. See fig. 12 in section 11.4 Adjustment of impeller clearance .
3. The pump's thermal switch trips when the pump has been operating for some time.	a) Too high liquid temperature.	Reduce the liquid temperature.
	b) Too high liquid viscosity.	Dilute the liquid.
	c) Wrong electrical connection. (If the pump is star-connected to a delta connection, the result will be very low undervoltage).	Check and correct the electrical installation.
4. The pump operates at below-standard performance and increased power consumption.	a) The impeller is blocked by impurities.	Clean the impeller.
	b) Wrong direction of rotation.	Check the direction of rotation. If is not correct, interchange two phases. See section 10.3 Direction of rotation .
5. The pump runs but gives no liquid.	a) The outlet valve is closed or blocked.	Check the outlet valve and open or clean it.
	b) The non-return valve blocked.	Clean the non-return valve.
	c) Air in the pump.	Vent the pump.
6. The pump is blocked.	a) The grinder system is worn.	Replace the grinder system.

13. Technical data

Supply voltage

- 1 x 208-230 V - 10 %/+ 6 %, 60 Hz
- 3 x 200-230 V - 10 %/+ 6 %, 60 Hz
- 3 x 460 V - 10 %/+ 6 %, 60 Hz
- 3 x 575 V - 10 %/+ 6 %, 60 Hz.

Enclosure class

IP68. According to IEC 60529.

Explosion protection classification

Class 1, division 1, group C and D, T4, T3, IP68.

Insulation class

F [311 °F (155 °C)].

Pump curves

Pump curves are available at www.grundfos.com.

The curves are to be considered as a guide. They must not be used as guarantee curves.

Test curves for the supplied pump are provided with the pump.

Sound pressure level

The sound pressure level of the pumps is lower than the limiting values stated in the EC Council Directive 2006/42/EC relating to machinery.

14. Disposal

This product or parts of it must be disposed of in an environmentally sound way:

1. Use the public or private waste collection service.
2. If this is not possible, contact the nearest Grundfos company or service workshop.

Subject to alterations.

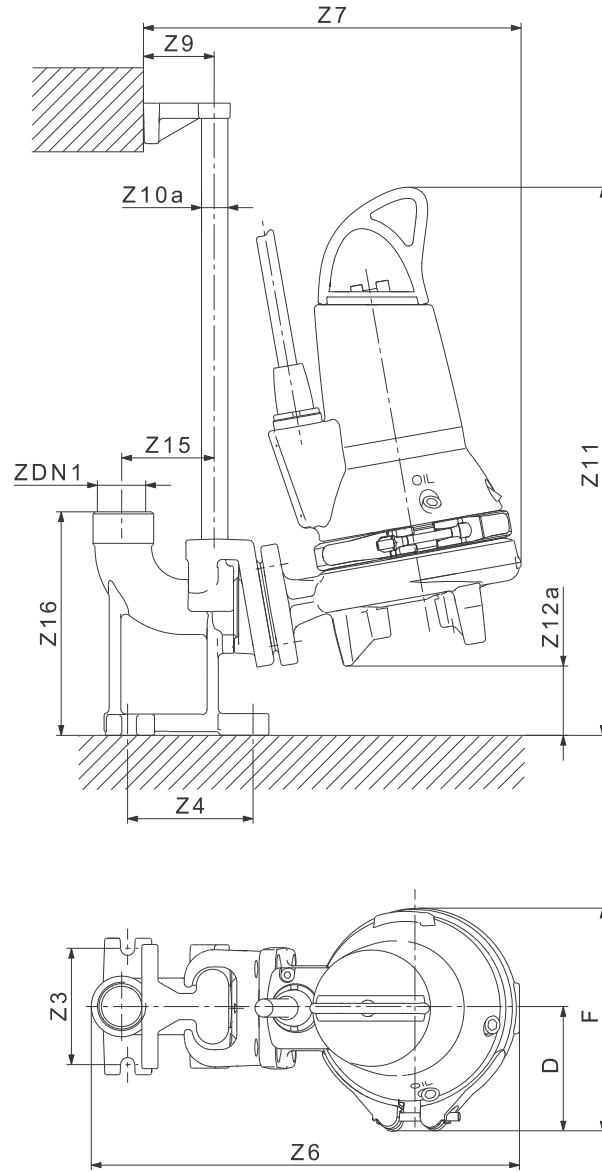

Fig. 1 One-pump installation on auto coupling

TM06 5743 0316

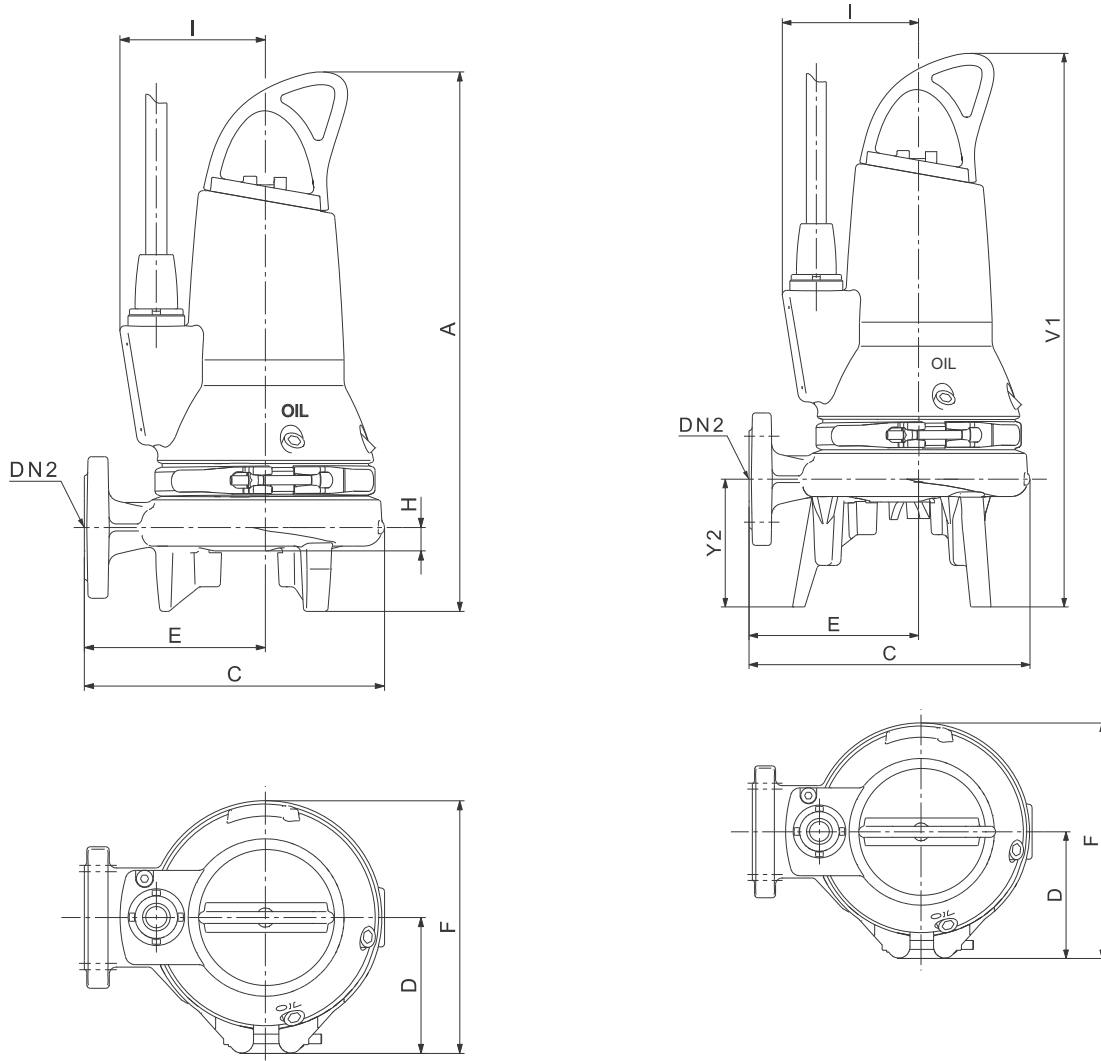

Fig. 2 Free-standing installation

TM06 5742 0316 - TM06 5745 0316

Dimensions

		Power [hp (kW)]	A	B	C	D	DN2	E	F	G1	H	I	M	N
SEGA15	2.0 (1 phase) (1.5)	Inch	18.98	3.94	9.92	3.9	1 1/2"	6.06	8.5	8.5	2.87	4.84	5.28	3.94
		mm	482	100	252	99	DN40	154	216	216	73	123	134	100
	2.0 (3 phase) (1.5)	Inch	18.39	3.94	10	3.9	1 1/2"	6.06	8.5	8.2	2.8	4.84	5.28	3.94
		mm	467	100	255	99	DN40	154	216	214	71	123	134	100
	3.0 (2.6)	Inch	20.51	3.94	11.5	4.68	1 1/2"	6.81	10	8.46	2.36	5.63	5.27	3.94
		mm	521	100	292	119	DN40	173	256	215	60	143	134	100
4.0 and 5.5 (3.1 and 4.0)	Inch	22.09	3.94	11.5	4.68	1 1/2"	6.81	10	8.42	2.36	5.67	5.27	3.94	
	mm	561	100	292	119	DN40	173	256	214	60	144	134	100	
SEGA20	3.0 (2.6)	Inch	20.94	3.94	11.54	4.69	2"	6.81	10	8.86	2.36	5.63	5.27	3.94
		mm	532	100	293	119	DN50	173	256	225	60	143	134	100
	4.0 and 5.5 (3.1 and 4.0)	Inch	22.52	3.94	11.54	4.69	2"	6.81	10	8.86	2.36	5.63	5.27	3.94
		mm	572	100	293	119	DN50	173	256	225	60	143	134	100

		Power [hp (kW)]	O	V1	Y2	Z3	Z4	Z6	Z6a	Z7	Z9	Z10a	Z11
SEGA15	2.0 (1 phase) (1.5)	Inch		20.67	4.57	4.53	4.65	16.57	16.57	14.25	2.76	3/4" - 1"	22.08
		mm		525	116	115	118	421	362	371	70	3/4" - 1"	561
	2.0 (3 phase) (1.5)	Inch		20.08	4.56	4.53	4.65	16.7	14.3	14.7	2.75	3/4" - 1"	21.50
		mm		510	116	115	118	424	365	374	70	3/4" - 1"	546
	3.0 (2.6)	Inch	min.	22.72	4.52	4.5	4.65	18.15	14.3	16.1	2.75	3/4" - 1"	24.17
		mm	23.6 (600)	577	115	115	118	460	365	410	70	3/4" - 1"	614
4.0 and 5.5 (3.1 and 4.0)	Inch		24.29	4.52	4.53	4.65	18.15	10.4	16.1	2.75	3/4" - 1"	25.63	
	mm		617	115	115	118	460	265	410	70	3/4" - 1"	651	
SEGA20	3.0 (2.6)	Inch		22.72	4.52	4.53	4.65	18.15	14.4	16.18	2.76	3/4" - 1"	24.76
		mm		577	115	115	118	460	366	411	70	3/4" - 1"	625
	4.0 and 5.5 (3.1 and 4.0)	Inch		24.29	4.52	4.53	4.65	18.15	14.4	16.18	2.76	3/4" - 1"	26.06
		mm		617	115	115	118	460	366	411	70	3/4" - 1"	662

		Power [hp (kW)]	Z12a	Z15	Z16	Z18	Z19	ZDN1
SEGA15	2.0 (1 phase) (1.5)	Inch	2.6	3.54	8.7	10.67	4.72	NPT 1 1/2
		mm	66	90	221	271	120	Rp 1 1/2
	2.0 (3 phase) (1.5)	Inch	2.67	3.54	8.7	10.67	4.72	NPT 1 1/2
		mm	68	90	221	271	120	Rp 1 1/2
	3.0 (2.6)	Inch	3.14	3.54	8.7	10.67	4.72	NPT 1 1/2
		mm	80	90	221	271	120	Rp 1 1/2
4.0 and 5.5 (3.1 and 4.0)	Inch	3.11	3.54	8.7	10.6	4.72	NPT 1 1/2	
	mm	79	90	221	271	120	Rp 1 1/2	
SEGA20	3.0 (2.6)	Inch	3.15	3.54	8.7	10.6	4.72	NPT 2
		mm	80	90	221	271	120	Rp 2
	4.0 and 5.5 (3.1 and 4.0)	Inch	3.15	3.54	8.7	10.6	4.72	NPT 2
		mm	80	90	221	271	120	Rp 2

Weights

	Power [hp (kW)]	Weight [lb (kg)]
SEGA15	2.0 (1 phase) (1.5)	101.4 (46)
	2.0 (3 phase) (1.5)	101.4 (46)
	3.0 (2.6)	101.4 (46)
	4.0 and 5.5 (3.1 and 4.0)	178.6 (81)
SEGA20	3.0 (2.6)	101.4 (46)
	4.0 and 5.5 (3.1 and 4.0)	178.6 (81)

Pos.	Designation GB
6a	Pin
7a	Rivet
9a	Key
37a	O-rings
44	Grinder ring
45	Grinder head
48	Stator
48a	Terminal board
49	Impeller
50	Pump housing
55	Stator housing
58	Shaft seal carrier
66	Locking ring
68	Adjusting nut
76	Nameplate
92	Clamp
102	O-ring
103	Bush
104	Seal ring
105 105a	Shaft seal
107	O-rings
112a	Locking ring
153	Bearing
154	Bearing
155	Oil chamber
158	Corrugated spring
159	Washer
172	Rotor/shaft
173	Screw
173a	Washer
176	Inner plug part
181	Outer plug part
188a	Screw
190	Lifting bracket
193	Oil screw
193a	Oil
194	Gasket
198	O-ring

Sectional drawings

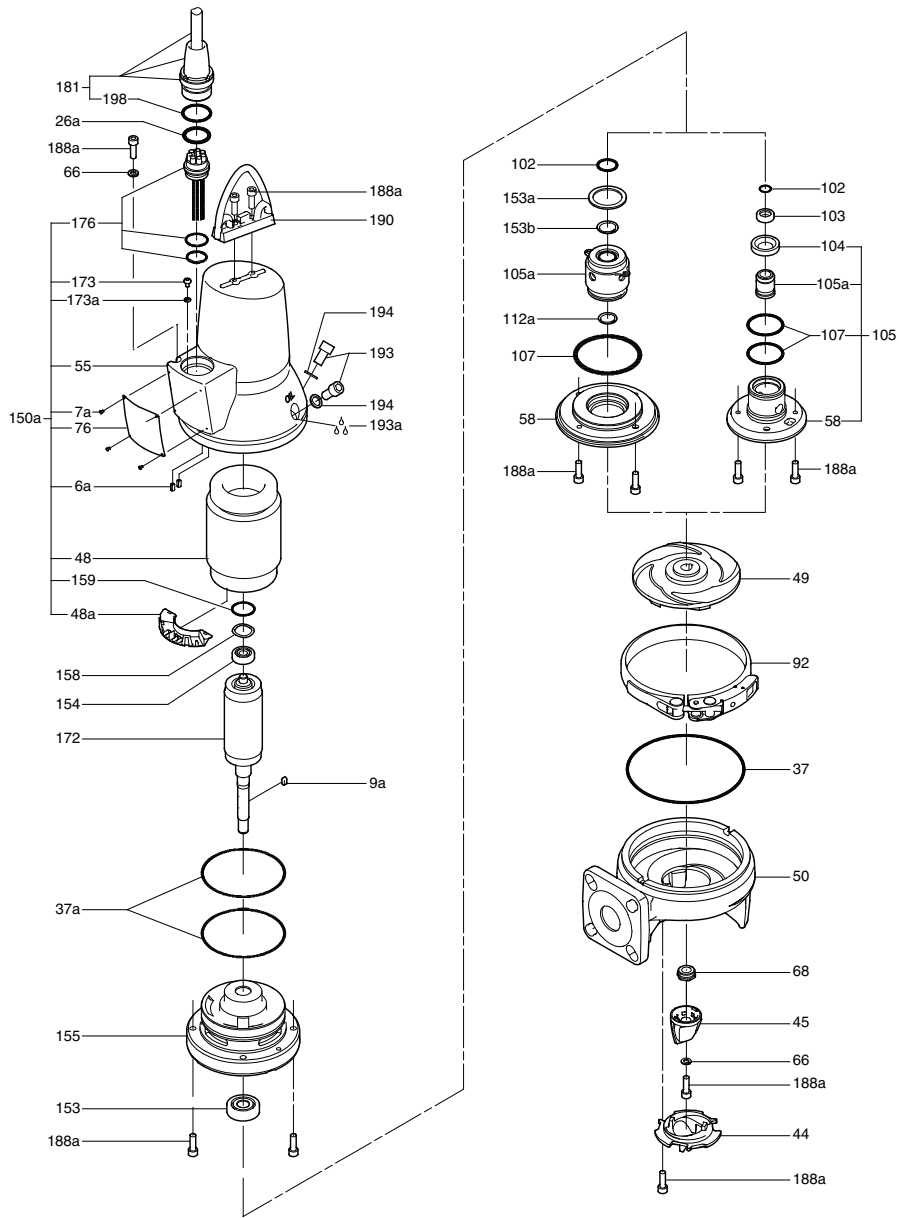

Fig. 3 SEG, 2.0 hp (1.5 kW)

TM02 5616 37/02

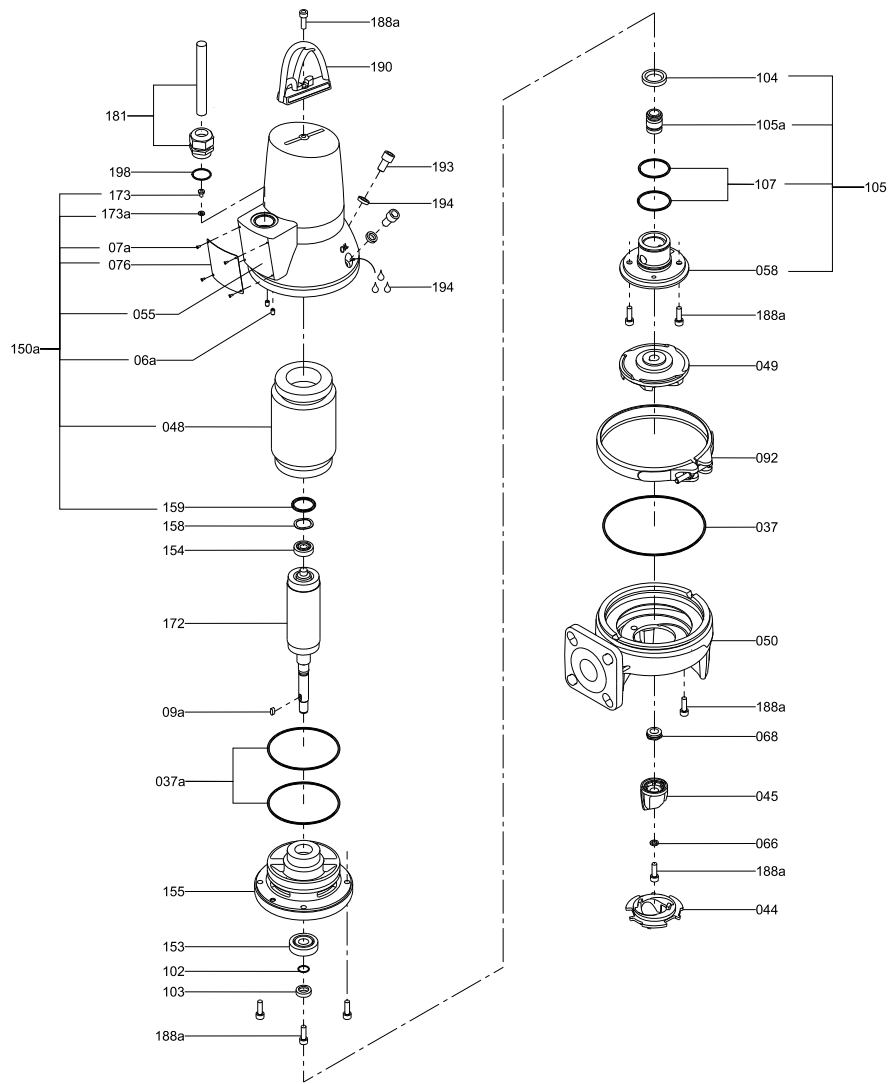

Fig. 4 SEG L, 2.0 Hp (1.5 kW)

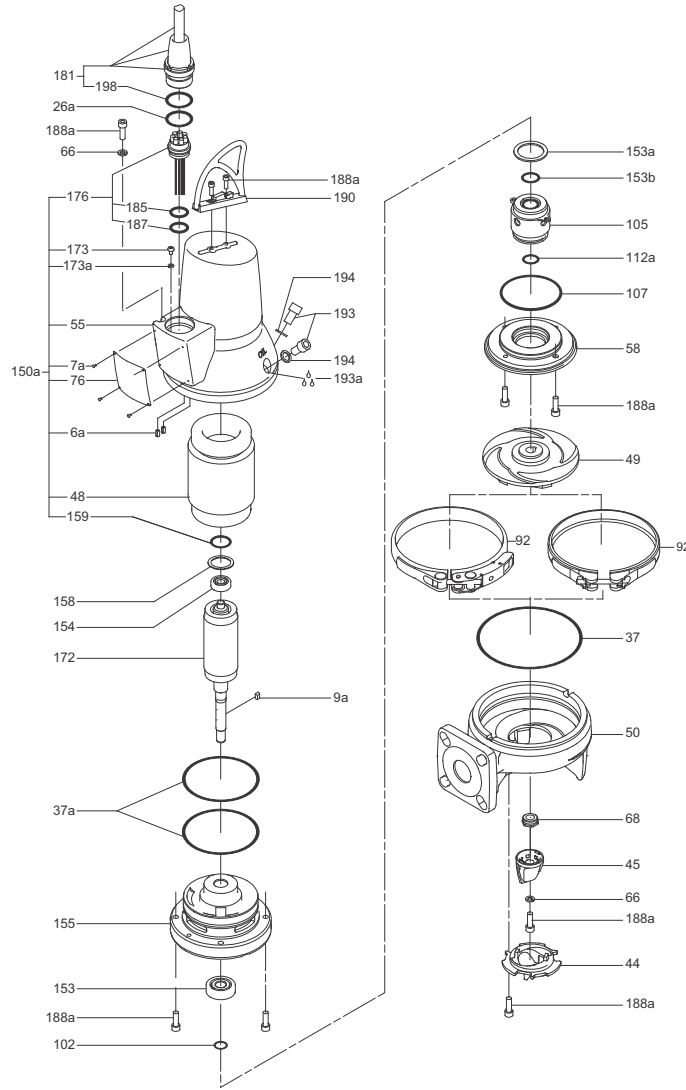

Fig. 5 SEG, 3.0 - 5.5 Hp (2.6 - 4.0 kW)

TM06 5759 0316

Appendix

Schémas d'encombrement

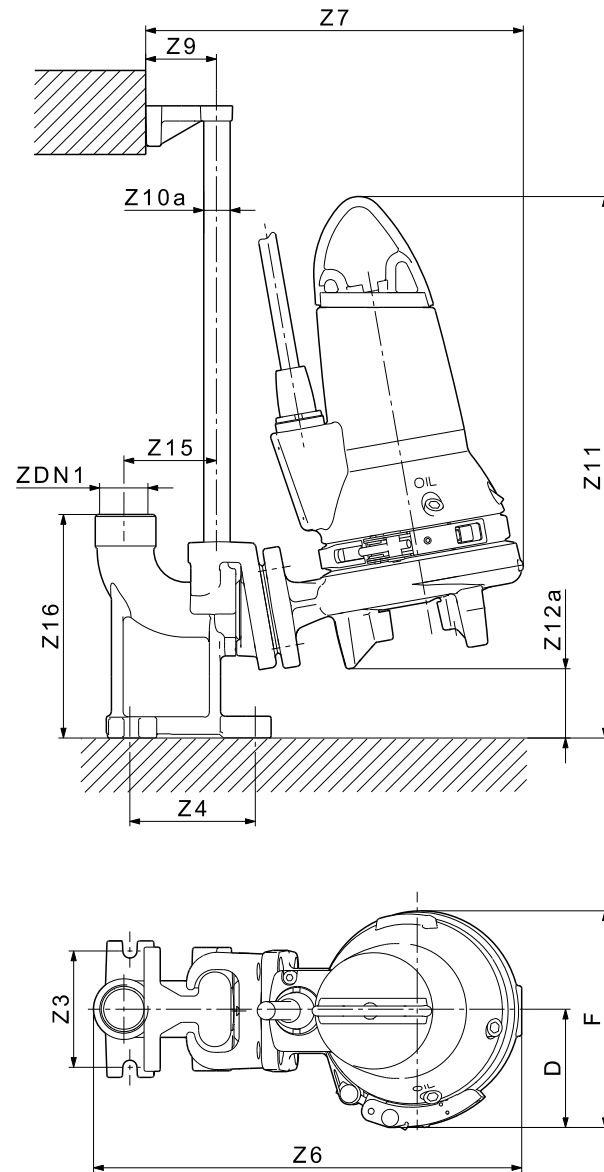

Fig. 1 Installation pompe unique sur accouplement automatique

TM02 5388 1310

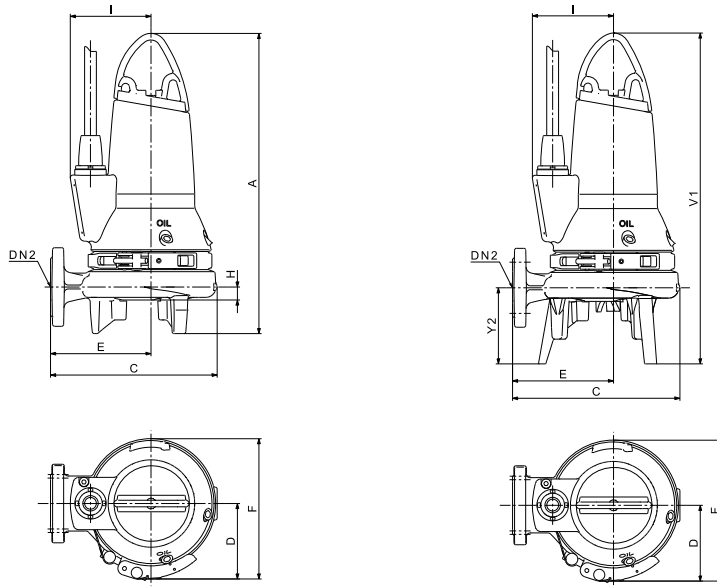

Fig. 2 Installation autonome

TM02 5387 1310 - TM02 5974 1310

Tables de dimensions

		Puissance [CV (kW)]	A	B	C	D	DN2	E	F	G1	H	I	M
SEGA15	2.0 (1 phase) (1.5)	Pouces	18.98	3.94	9.92	3.9	1 1/2"	6.06	8.5	8.5	2.87	4.84	5.28
		mm	482	100	252	99	DN40	154	216	216	73	123	134
	2.0 (3 phases) (1.5)	Pouces	18.39	3.94	10	3.9	1 1/2"	6.06	8.5	8.2	2.8	4.84	5.28
		mm	467	100	255	99	DN40	154	216	214	71	123	134
	3.0 (2.6)	Pouces	20.51	3.94	11.5	4.68	1 1/2"	6.81	10	8.46	2.36	5.63	5.27
		mm	521	100	292	119	DN40	173	256	215	60	143	134
4.0 and 5.5 (3.1 and 4.0)	Pouces	22.09	3.94	11.5	4.68	1 1/2"	6.81	10	8.42	2.36	5.67	5.27	
	mm	561	100	292	119	DN40	173	256	214	60	144	134	
SEGA20	3.0 (2.6)	Pouces	20.94	3.94	11.54	4.69	2"	6.81	10	8.86	2.36	5.63	5.27
		mm	532	100	293	119	DN50	173	256	225	60	143	134
	4.0 and 5.5 (3.1 and 4.0)	Pouces	22.52	3.94	11.54	4.69	2"	6.81	10	8.86	2.36	5.63	5.27
		mm	572	100	293	119	DN50	173	256	225	60	143	134

		Puissance [CV (kW)]	N	O	V1	Y2	Z3	Z4	Z6	Z6a	Z7	Z9
SEGA15	2.0 (1 phase) (1.5)	Pouces	3.94		20.67	4.57	4.53	4.65	16.57	16.57	14.25	2.76
		mm	100		525	116	115	118	421	362	371	70
	2.0 (3 phases) (1.5)	Pouces	3.94		20.08	4.56	4.52	4.64	16.7	14.3	14.7	2.75
		mm	100		510	116	115	118	424	365	374	70
	3.0 (2.6)	Pouces	3.94	min.	22.72	4.52	4.52	4.64	18.1	14.3	16.1	2.75
		mm	100	23.6 (600)	577	115	115	118	460	365	410	70
4.0 and 5.5 (3.1 and 4.0)	Pouces	3.94		24.29	4.52	4.52	4.64	18.1	10.4	16.1	2.75	
	mm	100		617	115	115	118	460	265	410	70	
SEGA20	3.0 (2.6)	Pouces	3.94		22.72	4.52	4.53	4.65	18.15	14.4	16.18	2.76
		mm	100		577	115	115	118	460	366	411	70
	4.0 and 5.5 (3.1 and 4.0)	Pouces	3.94		24.29	4.52	4.53	4.65	18.15	14.4	16.18	2.76
		mm	100		617	115	115	118	460	366	411	70

		Puissance [CV (kW)]	Z10a	Z11	Z12a	Z15	Z16	Z18	Z19	ZDN1
SEGA15	2.0 (1 phase) (1.5)	Pouces	3/4" - 1"	22.08	2.6	3.54	8.7	10.67	4.72	NPT 1 1/2
		mm	3/4" - 1"	561	66	90	221	271	120	Rp 1 1/2
	2.0 (3 phases) (1.5)	Pouces	3/4" - 1"	21.50	2.67	3.54	8.7	10.67	4.72	NPT 1 1/2
		mm	3/4" - 1"	546	68	90	221	271	120	Rp 1 1/2
	3.0 (2.6)	Pouces	3/4" - 1"	24.17	3.14	3.54	8.7	10.67	4.72	NPT 1 1/2
		mm	3/4" - 1"	614	80	90	221	271	120	Rp 1 1/2
4.0 and 5.5 (3.1 and 4.0)	Pouces	3/4" - 1"	25.63	3.11	3.54	8.7	10.6	4.72	NPT 1 1/2	
	mm	3/4" - 1"	651	79	90	221	271	120	Rp 1 1/2	
SEGA20	3.0 (2.6)	Pouces	3/4" - 1"	24.76	3.15	3.54	8.7	10.6	4.72	NPT 2
		mm	3/4" - 1"	625	80	90	221	271	120	Rp 2
	4.0 and 5.5 (3.1 and 4.0)	Pouces	3/4" - 1"	26.06	3.15	3.54	8.7	10.6	4.72	NPT 2
		mm	3/4" - 1"	662	80	90	221	271	120	Rp 2

Table de poids

	Puissance [CV (kW)]	Poids [lb (kg)]
SEGA15	2.0 (1 phase) (1.5)	101.4 (46)
	2.0 (3 phases) (1.5)	101.4 (46)
	3.0 (2.6)	101.4 (46)
	4.0 and 5.5 (3.1 and 4.0)	178.6 (81)
SEGA20	3.0 (2.6)	101.4 (46)
	4.0 and 5.5 (3.1 and 4.0)	178.6 (81)

Pos.	Désignation FR
6a	Broche
7a	Rivet
9a	Clavette
37a	Joints toriques
44	Anneau du broyeur
45	Tête broyeur
48	Stator
48a	Plaque à bornes
49	Roue
50	Corps de pompe
55	Boîtier du stator
58	Porte-garniture mécanique
66	Bague de serrage
68	Écrou de réglage
76	Plaque signalétique
92	Collier
102	Joint torique
103	Douille
104	Bague d'étanchéité
105 105a	Garniture mécanique
107	Joints toriques
112a	Bague de serrage
153	Palier
154	Palier
155	Chambre à huile
158	Ressort ondulé
159	Rondelle
172	Rotor/arbre
173	Vis
173a	Rondelle
176	Partie bouchon intérieur
181	Partie bouchon extérieur
188a	Vis
190	Ferrure de levage
193	Bouchon d'huile
193a	Huile
194	Joint
198	Joint torique

Dessins en coupe

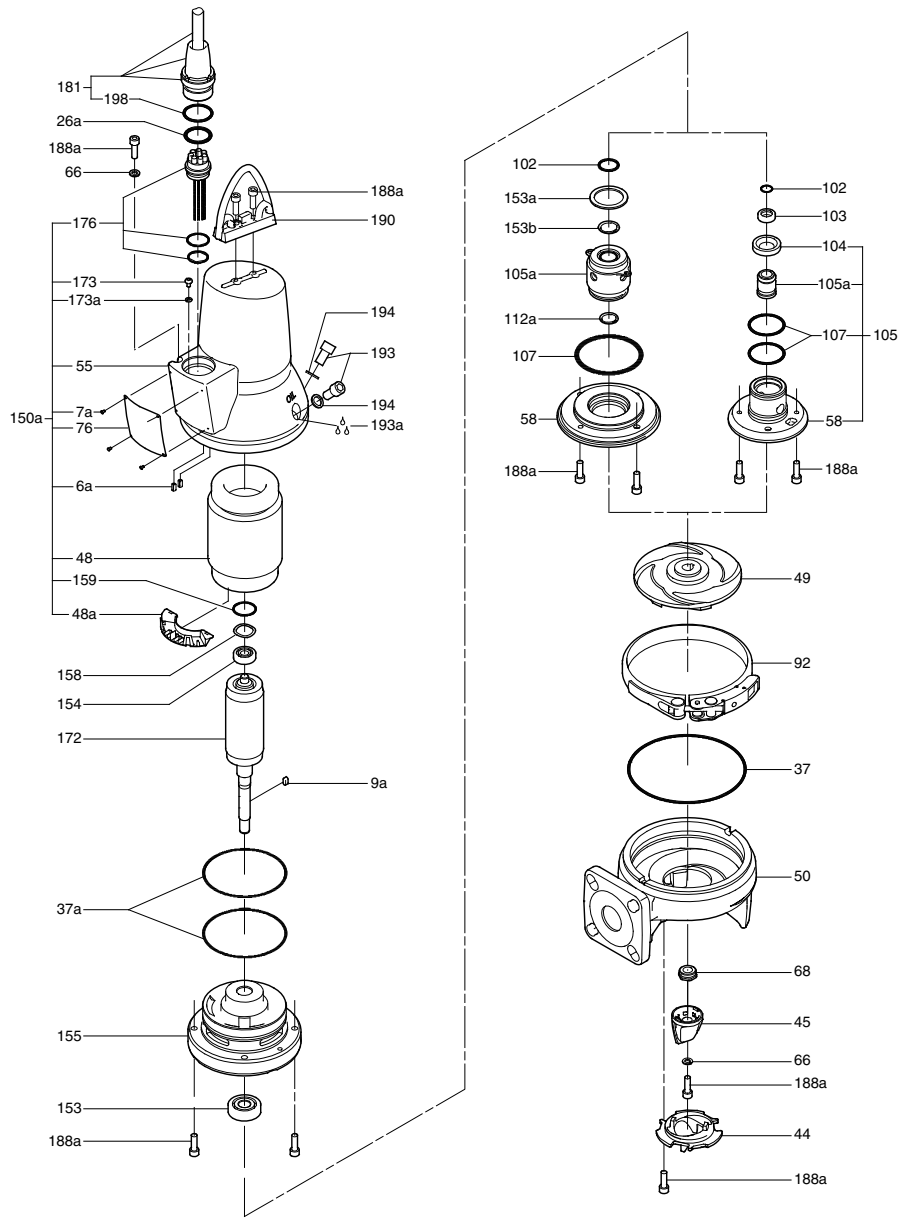

Fig. 3 SEG, 2.0 CV (1.5 kW)

TM02 5616 3702

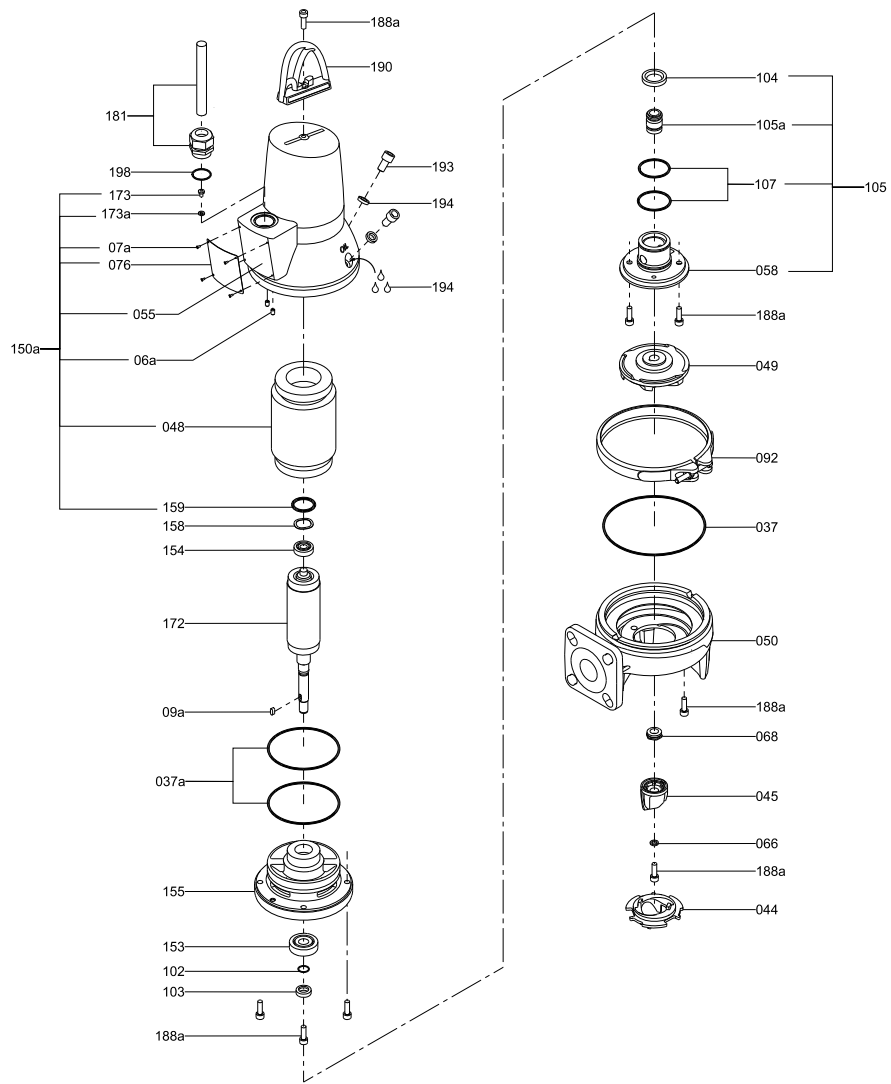

Fig. 4 SEG L - pompe, 2.0 CV (1.5 kW)

TM05 8411 2313

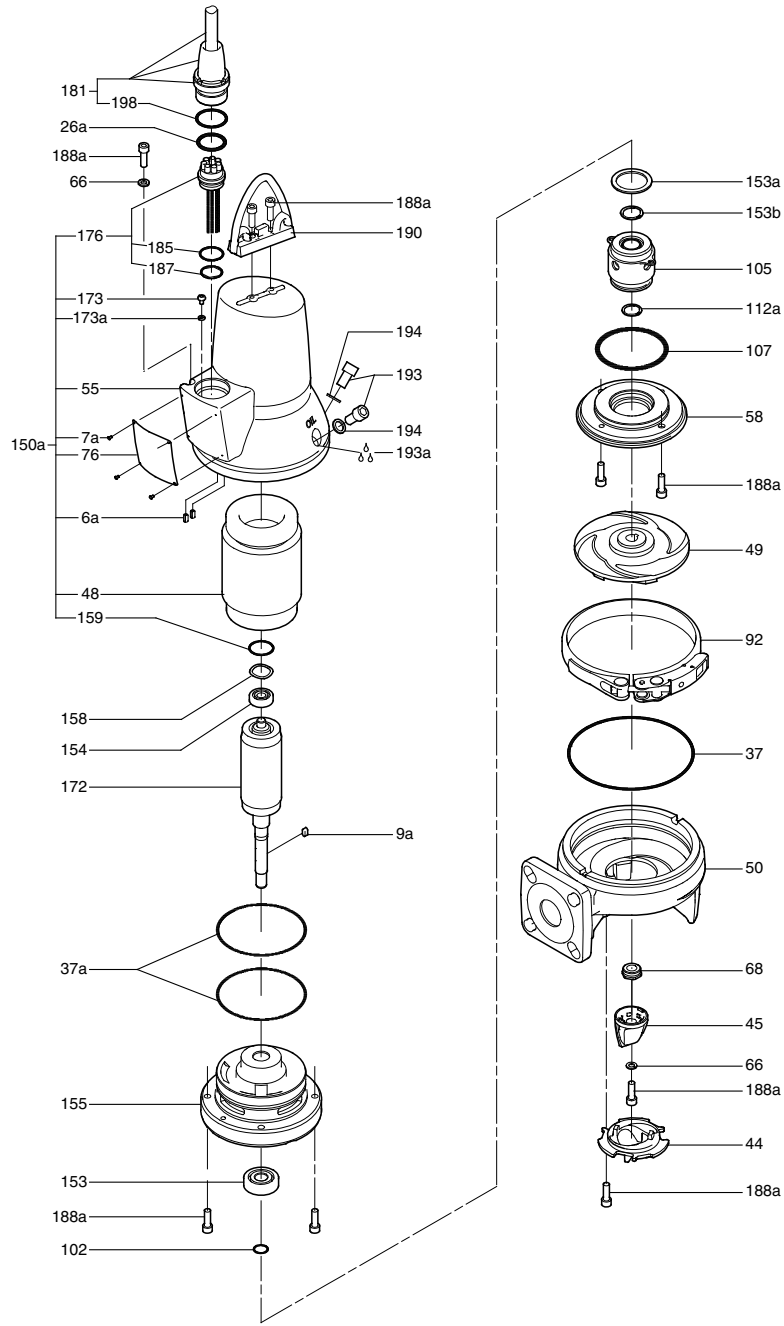

Fig. 5 SEG, 3.0 à 5.5 CV (2.6 à 4.0 kW)

TM02 5407 2804

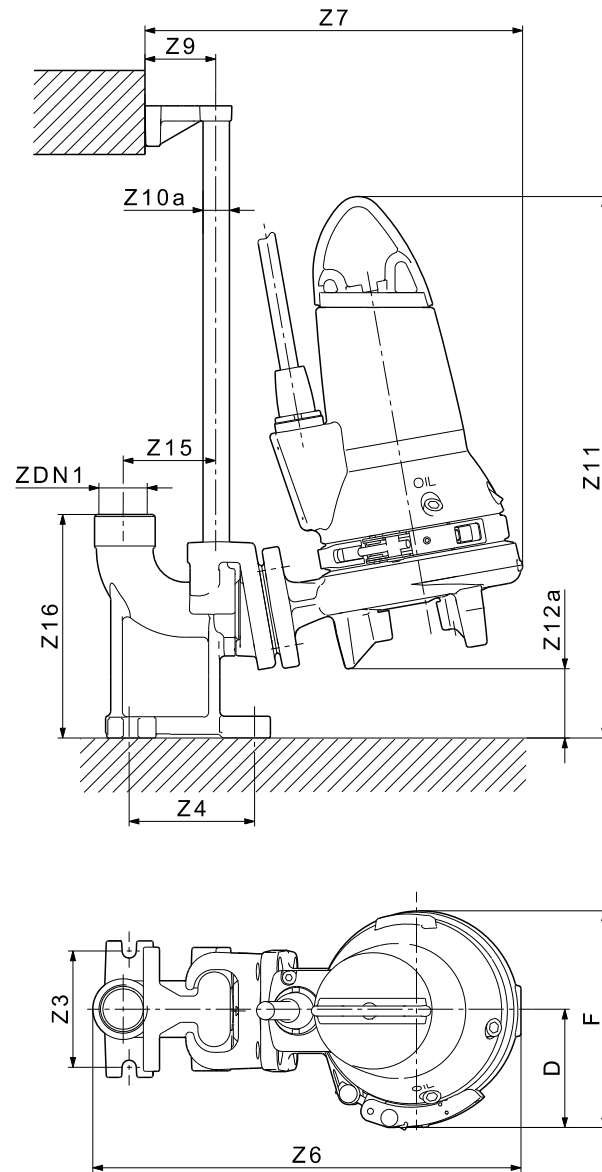

Fig. 1 Instalación compuesta por una bomba con acoplamiento automático

TM02.5388 1310

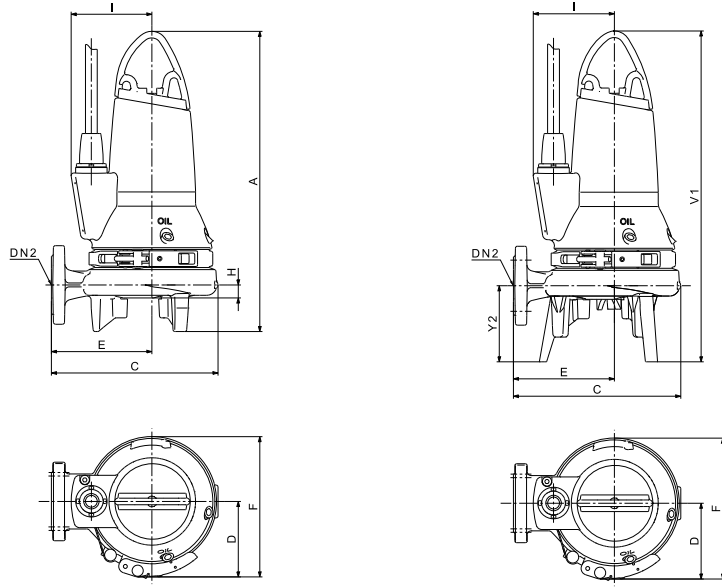

Fig. 2 Instalación en posición libre

TM02 5387 1310 - TM02 5974 1310

Tablas de dimensiones

		Potencia [hp (kW)]	A	B	C	D	DN2	E	F	G1	H	I	M	N
SEGA15	2.0 (monofásica) (1.5)	in	18.98	3.94	9.92	3.9	1 1/2"	6.06	8.5	8.5	2.87	4.84	5.28	3.94
		mm	482	100	252	99	DN40	154	216	216	73	123	134	100
	2.0 (trifásica) (1.5)	in	18.39	3.94	10	3.9	1 1/2"	6.06	8.5	8.2	2.8	4.84	5.28	3.94
		mm	467	100	255	99	DN40	154	216	214	71	123	134	100
	3.0 (2.6)	in	20.51	3.94	11.5	4.68	1 1/2"	6.81	10	8.46	2.36	5.63	5.27	3.94
		mm	521	100	292	119	DN40	173	256	215	60	143	134	100
4.0 and 5.5 (3.1 and 4.0)	in	22.09	3.94	11.5	4.68	1 1/2"	6.81	10	8.42	2.36	5.67	5.27	3.94	
	mm	561	100	292	119	DN40	173	256	214	60	144	134	100	
SEGA20	3.0 (2.6)	in	20.94	3.94	11.54	4.69	2"	6.81	10	8.86	2.36	5.63	5.27	3.94
		mm	532	100	293	119	DN50	173	256	225	60	143	134	100
	4.0 and 5.5 (3.1 and 4.0)	in	22.52	3.94	11.54	4.69	2"	6.81	10	8.86	2.36	5.63	5.27	3.94
		mm	572	100	293	119	DN50	173	256	225	60	143	134	100
		Potencia [hp (kW)]	O	V1	Y2	Z3	Z4	Z6	Z6a	Z7	Z9	Z10a	Z11	
SEGA15	2.0 (monofásica) (1.5)	in		20.67	4.57	4.53	4.65	16.57	16.57	14.25	2.76	3/4" - 1"	22.08	
		mm		525	116	115	118	421	362	371	70	3/4" - 1"	561	
	2.0 (trifásica) (1.5)	in		20.08	4.56	4.52	4.64	16.7	14.3	14.7	2.75	3/4" - 1"	21.50	
		mm		510	116	115	118	424	365	374	70	3/4" - 1"	546	
	3.0 (2.6)	in	mín. 23.6 (600)	22.72	4.52	4.52	4.64	18.1	14.3	16.1	2.75	3/4" - 1"	24.17	
		mm		577	115	115	118	460	365	410	70	3/4" - 1"	614	
4.0 and 5.5 (3.1 and 4.0)	in		24.29	4.52	4.52	4.64	18.1	10.4	16.1	2.75	3/4" - 1"	25.63		
	mm		617	115	115	118	460	265	410	70	3/4" - 1"	651		
SEGA20	3.0 (2.6)	in		22.72	4.52	4.53	4.65	18.15	14.4	16.18	2.76	3/4" - 1"	24.76	
		mm		577	115	115	118	460	366	411	70	3/4" - 1"	625	
	4.0 and 5.5 (3.1 and 4.0)	in		24.29	4.52	4.53	4.65	18.15	14.4	16.18	2.76	3/4" - 1"	26.06	
		mm		617	115	115	118	460	366	411	70	3/4" - 1"	662	
		Potencia [hp (kW)]	Z12a	Z15	Z16	Z18	Z19	ZDN1						
SEGA15	2.0 (monofásica) (1.5)	in	2.6	3.54	8.7	10.67	4.72	NPT 1 1/2						
		mm	66	90	221	271	120	Rp 1 1/2						
	2.0 (trifásica) (1.5)	in	2.67	3.54	8.7	10.67	4.72	NPT 1 1/2						
		mm	68	90	221	271	120	Rp 1 1/2						
	3.0 (2.6)	in	3.14	3.54	8.7	10.67	4.72	NPT 1 1/2						
		mm	80	90	221	271	120	Rp 1 1/2						
4.0 and 5.5 (3.1 and 4.0)	in	3.11	3.54	8.7	10.6	4.72	NPT 1 1/2							
	mm	79	90	221	271	120	Rp 1 1/2							
SEGA20	3.0 (2.6)	in	3.15	3.54	8.7	10.6	4.72	NPT 2						
		mm	80	90	221	271	120	Rp 2						
	4.0 and 5.5 (3.1 and 4.0)	in	3.15	3.54	8.7	10.6	4.72	NPT 2						
		mm	80	90	221	271	120	Rp 2						

Tabla de peso

	Potencia [hp (kW)]	Peso [lb (kg)]
SEGA15	2.0 (monofásica) (1.5)	101.4 (46)
	2.0 (trifásica) (1.5)	101.4 (46)
	3.0 (2.6)	101.4 (46)
	4.0 and 5.5 (3.1 and 4.0)	178.6 (81)
SEGA20	3.0 (2.6)	101.4 (46)
	4.0 and 5.5 (3.1 and 4.0)	178.6 (81)

Pos.	Descripción ES
6a	Pasador
7a	Remache
9a	Chaveta
37a	Juntas tóricas
44	Anillo triturador
45	Cabezal triturador
48	Estátor
48a	Placa terminal
49	Impulsor
50	Carcasa de la bomba
55	Carcasa del estátor
58	Soporte del sello del eje
66	Anillo de bloqueo
68	Tuerca de ajuste
76	Placa de características
92	Abrazadera
102	Junta tórica
103	Casquillo
104	Anillo de sello
105 105a	Sello del eje
107	Juntas tóricas
112a	Anillo de bloqueo
153	Cojinete
154	Cojinete
155	Cámara de aceite
158	Muelle ondulado
159	Arandela
172	Rotor/eje
173	Tornillo
173a	Arandela
176	Pieza interior del conector
181	Pieza exterior del conector
188a	Tornillo
190	Soporte de izado
193	Tornillo del aceite
193a	Aceite
194	Junta
198	Junta tórica

Planos seccionales

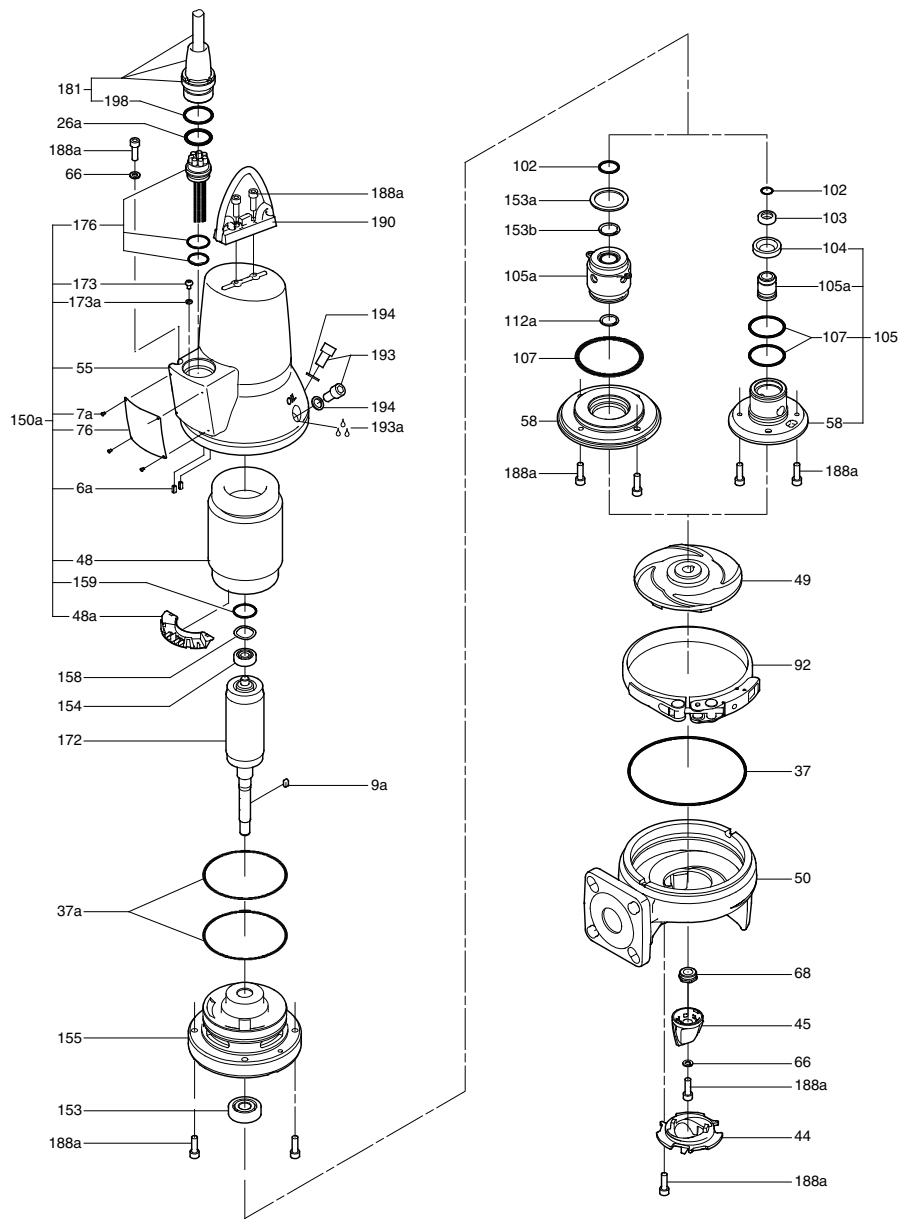

Fig. 3 SEG, 2.0 hp (1.5 kW)

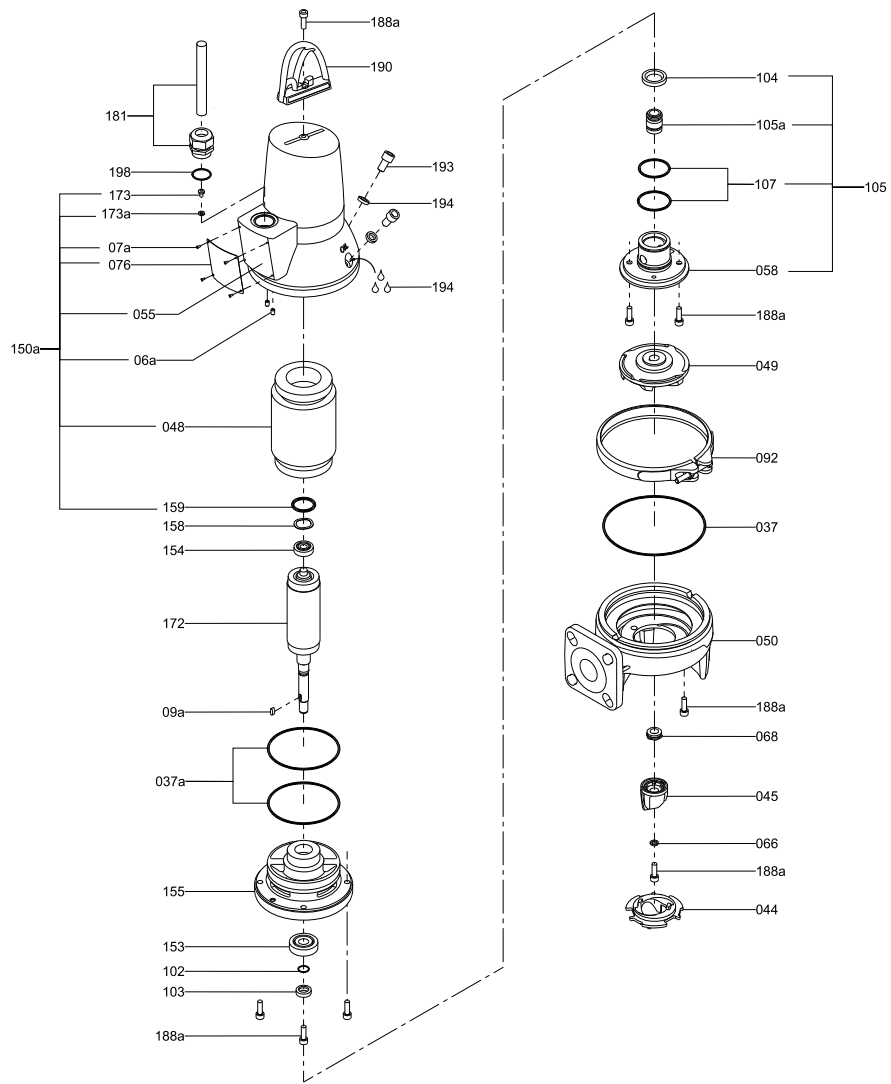

Fig. 4 SEG L, 2.0 hp (1.5 kW)

TM05 8411 2313

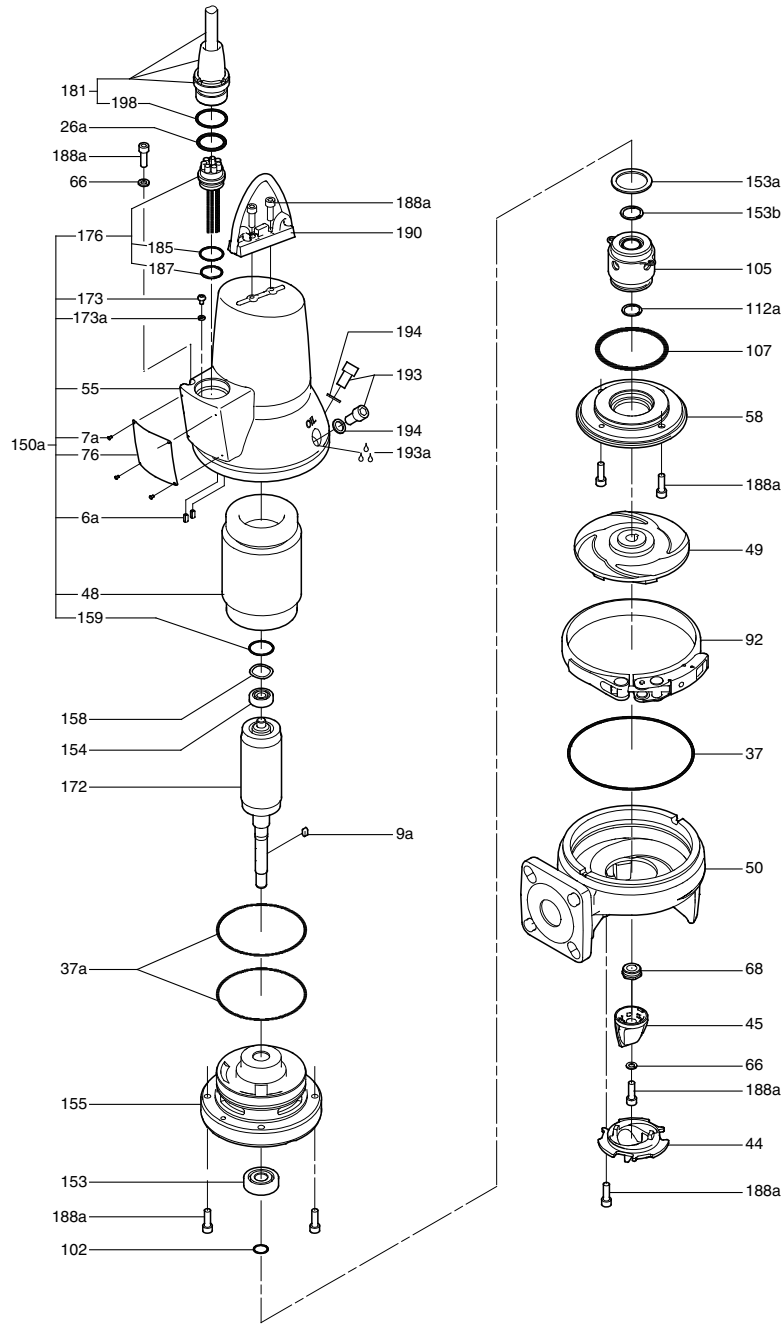

Fig. 5 SEG, 3.0 a 5.5 hp (2.6 a 4.0 kW)

TM02 5407 2804

USA

GRUNDFOS Chicago
3905 Enterprise Court
P.O. Box 6620
Aurora, IL 60598-0620
Phone: +1-630-236-5500
Fax: +1-630-236-5511

GRUNDFOS Kansas City
17100 West 118th Terrace
Olathe, KS 66061
Phone: +1-913 227 3400
Fax: +1-913 227 3500

Canada

GRUNDFOS Canada
2941 Brighton Road
Oakville, Ontario L6H 6C9 Canada
Phone: +1-905 829 9533
Telefax: +1-905 829 9512

www.grundfos.ca

México

GRUNDFOS México
Boulevard TLC No. 15
Parque Industrial Stiva Aeropuerto
C.P. 66600 Apodaca, N.L. México
Phone: +52-81-8144 4000
Telefax: +52-81-8144 4010

www.grundfos.mx

98449106 0216
ECM: 1169529

The name Grundfos, the Grundfos logo, and be think innovate are registered trademarks owned by Grundfos Holding A/S or Grundfos A/S, Denmark. All rights reserved worldwide. © Copyright Grundfos Holding A/S