

LC, LCV, LF, LCS

End-suction centrifugal pumps

Installation and operating instructions



English (US) Installation and operating instructions

Original installation and operating instructions

These installation and operating instructions describe LC, LCV, LF, and LCS pumps.

Sections 1-6 give the information necessary to be able to unpack, install and start up the product in a safe way.

Sections 7-12 give important information about the product, as well as information on service, fault finding and disposal of the product.

CONTENTS

	Page
1. Limited warranty	4
2. General information	4
2.1 Symbols used in this document	4
2.2 Other important notes	4
3. Receiving the product	5
3.1 Unpacking the product	5
3.2 Inspecting the product	5
3.3 Temporary storage after delivery	5
4. Installing the product	5
4.1 Location	5
4.2 Pump foundation	5
4.3 Securing the base plate	6
4.4 Mechanical installation	6
4.5 Electrical connection	8
5. Starting up the product	9
5.1 Priming	9
5.2 Pre-start checklist	9
5.3 Motor direction of rotation	10
5.4 Starting the pump	10
5.5 Voltage and frequency variation	10
6. Storing and handling the product	10
7. Product introduction	10
7.1 Applications	10
7.2 Pumped liquids	10
7.3 Pump identification	10
8. Servicing the product	11
8.1 Maintaining the product	11
8.2 Lubricating the product	11
8.3 Disassembling the pump	12
8.4 Replacing the shaft seal (LCS pumps)	13
8.5 Replacing the wear ring	14
8.6 Reassembling the pump	14
8.7 LF, exploded view and parts list	15
8.8 LC, cross section and parts list	16
8.9 LCV, cross section and parts list	17
8.10 LCS, exploded view and parts list	18
9. Taking the product out of operation	19
9.1 General procedure	19
9.2 Short-time shutdown	19
9.3 Long-term shutdown	19
10. Fault finding	20
11. Technical data	22
11.1 Operating conditions	22
12. Disposing of the product	22



Prior to installation, read these installation and operating instructions. Installation and operation must comply with local regulations and accepted codes of good practice.



The use of this product requires experience with and knowledge of the product. Persons with reduced physical, sensory or mental capabilities must not use this product, unless they are under supervision or have been instructed in the use of the product by a person responsible for their safety. Children must not use or play with this product.



CAUTION

Successful operation depends on careful attention to the procedures described in this manual. Keep this manual for future use.

1. Limited warranty

New equipment manufactured by seller or service supplied by seller is warranted to be free from defects in material and workmanship under normal use and service for a minimum of twelve (12) months from date of installation, eighteen (18) months from date of shipment, unless otherwise stated in product warranty guide (available upon request). In the case of spare or replacement parts manufactured by seller, the warranty period shall be for a period of twelve months from shipment. Seller's obligation under this warranty is limited to repairing or replacing, at its option, any part found to its satisfaction to be so defective, provided that such part is, upon request, returned to seller's factory from which it was shipped, transportation prepaid. Parts replaced under warranty shall be warranted for twelve months from the date of the repair, not to exceed the original warranty period. This warranty does not cover parts damaged by decomposition from chemical action or wear caused by abrasive materials, nor does it cover damage resulting from misuse, accident, neglect, or from improper operation, maintenance, installation, modification or adjustment. This warranty does not cover parts repaired outside seller's factory without prior written approval. Seller makes no warranty as to starting equipment, electrical apparatus or other material not of its manufacture. If purchaser or others repair, replace, or adjust equipment or parts without seller's prior written approval, seller is relieved of any further obligation to purchaser under this paragraph with respect to such equipment or parts, unless such repair, replacement, or adjustment was made after seller failed to satisfy within a reasonable time seller's obligations under this paragraph. Seller's liability for breach of these warranties (or for breach of any other warranties found by a court of competent jurisdiction to have been given by seller) shall be limited to: (a) accepting return of such equipment exw plant of manufacture, and (b) refunding any amount paid thereon by purchaser (less depreciation at the rate of 15 % per year if purchaser has used equipment for more than thirty [30] days), and canceling any balance still owing on the equipment, or (c) in the case of service, at seller's option, redoing the service, or refunding the purchase order amount of the service or portion thereof upon which such liability is based. These warranties are expressly in lieu of any other warranties, express or implied, and seller specifically disclaims any implied warranty of merchantability or fitness for a particular purpose, and in lieu of any other obligation or liability on the part of the seller whether a claim is based upon negligence, breach of warranty, or any other theory or cause of action. In no event shall seller be liable for any consequential, incidental, indirect, special or punitive damages of any kind. For purposes of this paragraph, the equipment warranted shall not include equipment, parts, and work not manufactured or performed by seller. With respect to such equipment, parts, or work, seller's only obligation shall be to assign to purchaser the warranties provided to seller by the manufacturer or supplier providing such equipment, parts or work. No equipment furnished by seller shall be deemed to be defective by reason of normal wear and tear, failure to resist erosive or corrosive action of any fluid or gas, purchaser's failure to properly store, install, operate, or maintain the equipment in accordance with good industry practices or specific recommendations of seller, including, but not limited to seller's installation and operation manuals, or purchaser's failure to provide complete and accurate information to seller concerning the operational application of the equipment.

2. General information

2.1 Symbols used in this document



DANGER

Indicates a hazardous situation which, if not avoided, will result in death or serious personal injury.



WARNING

Indicates a hazardous situation which, if not avoided, could result in death or serious personal injury.



CAUTION

Indicates a hazardous situation which, if not avoided, could result in minor or moderate personal injury.

The text accompanying the three hazard symbols DANGER, WARNING and CAUTION will be structured in the following way:



SIGNAL WORD

Description of hazard

Consequence of ignoring the warning.
- Action to avoid the hazard.

Example



DANGER

Electric shock

Death or serious personal injury.
- Before starting any work on the product, make sure that the power supply has been switched off and that it cannot be accidentally switched on.

2.2 Other important notes



A blue or grey circle with a white graphical symbol indicates that an action must be taken to avoid a hazard.



A red or grey circle with a diagonal bar, possibly with a black graphical symbol, indicates that an action must not be taken or must be stopped.



If these instructions are not observed, it may result in malfunction or damage to the equipment.



Notes or instructions that make the work easier and ensure safe operation.

3. Receiving the product

3.1 Unpacking the product



WARNING

Overhead load

Death or serious personal injury.

- Do not lift the product by the eye bolts on the motor.

Unload and handle the product with a sling.

3.2 Inspecting the product

- Check that the product received is in accordance with the order.
- Check that the voltage, phase and frequency of the product match the voltage, phase and frequency of the installation site. See section 7.3 *Pump identification*.
- Check the product for defects and damage immediately after receiving it. Any accessories ordered will be packed in a separate container and shipped with the product.
- If any equipment is damaged in transit, promptly report this to the carrier's agent. Make complete notations on the freight bill.

3.3 Temporary storage after delivery

- If the product is not to be installed and operated immediately after receiving it, store it in a clean, dry area at a moderate ambient temperature.
- Rotate the shaft by hand periodically, at least weekly, to coat the bearing with lubricant to retard oxidation and corrosion.
- Follow the motor manufacturer's storage recommendations where applicable.

4. Installing the product

4.1 Location

- Locate the pump as close as possible to the liquid supply. Use the shortest and most direct inlet pipe practical. Refer to 4.4.2 *Inlet pipe*.
- Locate the pump below system level wherever possible. This will facilitate priming, assure a steady liquid flow, and provide a positive inlet pressure.
- The net positive suction head (NPSH) available must always be equal to or exceed the required NPSH specified on the pump performance curve. Make sure the required NPSH is provided at the inlet.
- Always allow sufficient accessibility space for maintenance and inspection. Provide a clearance of 24 in. (610 mm) with ample head room for use of a hoist strong enough to lift the product.
- Electrical characteristics must match those specified on the motor nameplate, within the limits covered in section 5. *Starting up the product*.
- Do not expose the product to sub-zero temperatures to prevent the pumped liquid from freezing. If there is frost during shutdown periods, see sections 5. *Starting up the product* and 9.2 *Short-time shutdown*.

4.2 Pump foundation

- LF pumps must be grouted in order to ensure a stable pump and motor shaft alignment.
- LCS pumps do not require grouting to maintain shaft alignment, but grouting will increase pump stability within the pipe system.
- LC and LCV pumps do not need to be grouted.

Install the pump permanently on a firm, raised concrete foundation of sufficient size to dampen any vibration and prevent any deflection or shaft misalignment. The foundation may float on springs or be a raised part of the floor.

Proceed like this:

1. Pour the foundation without interruption to 0.75 - 1.5 in. (20-35 mm) below the final pump level. Leave the top of the foundation rough. Then clean and wet it down.
2. Scour and groove the top surface of the foundation before the concrete sets to provide a suitable bonding surface for the grout.
3. Place anchor bolts in pipe sleeves for positioning allowance. See fig. 1.
4. Allow enough bolt length for grout, base flange, nuts, and washers.
5. Allow the foundation to cure several days before proceeding to install the pump.

4.3 Securing the base plate

When the raised concrete foundation has been poured and allowed to set, proceed as follows:

1. Lower the base plate over the anchor bolts and rest it on loose adjustment wedges or shims placed near each anchor bolt and at intervals not exceeding 24 in. (610 mm) along each side.
2. Place the shims or wedges so that they raise the bottom of the base plate 0.75 - 1.25 in. (20-32 mm) above the foundation, allowing clearance for grout.
3. Level the pump shaft, flanges, and base plate using a spirit level, adjusting the wedges or shims, as required.



LCS pumps do not require alignment or grouting.

4. Make sure that the pipes can be aligned to the pump flanges without placing any strain on either flange.
5. After pump alignment has been established, put nuts on the anchor bolts and tighten them just enough to keep the base plate from moving.
6. Construct formwork around the concrete foundation and pour grout inside the base plate, as shown in fig. 1. The grout will compensate for uneven foundation, distribute the weight of the pump, and prevent shifting.



Use an approved, non-shrinking grout.

7. Allow at least 24 hours for the grout to set before proceeding with the pipe connections.
- After the grout has thoroughly hardened, check the foundation bolts and tighten them if necessary. Recheck the pump alignment after tightening the foundation bolts.

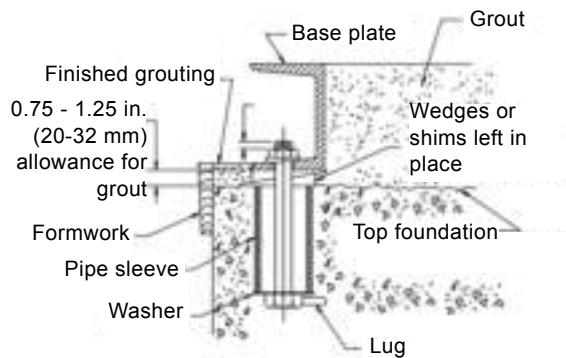

Fig. 1 Anchor bolt installation

TM 05 4775 2512

4.4 Mechanical installation

4.4.1 Piping



Do not let the pump support the pipes. Use pipe hangers or other supports at proper intervals to provide pipe support near the pump.

- Make sure that both the inlet and outlet pipes are independently supported and properly aligned so that no strain is transmitted to the pump when flange bolts are tightened.
- Make sure the pipes are as straight as possible, so as to avoid unnecessary bends and fittings. Where necessary, use 45 ° or long-sweep 90 ° pipe bends to decrease friction loss.
- Where flanged joints are used, make sure that inside diameters match properly and that mounting holes are aligned.
- Do not apply force to pipes when making any connections!

4.4.2 Inlet pipe

The inlet pipe must be installed in a manner that minimizes pressure loss and permits sufficient liquid flow into the pump during starting and operation.

Observe the following precautions when installing the inlet pipe:

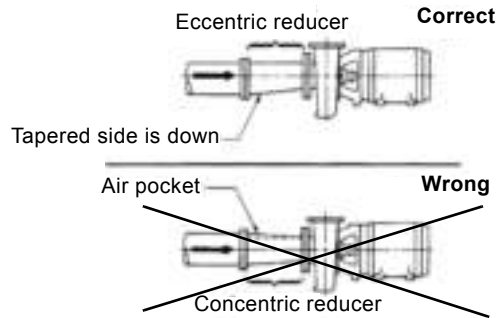

Fig. 2 Inlet pipe

- Run the inlet pipe as direct as possible, and ideally, make sure the length is at least ten times the pipe diameter. A short inlet pipe can be the same diameter as the inlet port. A long inlet pipe must be one or two sizes larger than the inlet port, depending on the length, and with a reducer between the pipe and the inlet port.
- Use an eccentric reducer, with the tapered side down. See fig. 2.

TM05 4791 2613



At no point must the diameter of the inlet pipe be smaller than that of the pump inlet port.

- If possible, run a horizontal inlet line along an even gradient. We recommend a gradual upward slope to the pump under suction lift conditions, and a gradual downward slope under positive inlet pressure conditions.
- Avoid any high points, such as pipe loops (see fig. 3), as this may create air pockets and throttle the system or cause erratic pumping.
- Install a gate valve in the inlet line to be able to isolate the pump during shutdown and maintenance, and to facilitate pump removal. Where two or more pumps are connected to the same inlet line, install two gate valves to be able to isolate each pump from the line.
- Always install gate or butterfly valves in positions that prevent air pockets.



Do not use globe valves, particularly when NPSH is critical.

- During pumping operation, the valves on the inlet line must always be fully open.
- Install properly sized pressure gauges in the tapped holes on the pump inlet and outlet flanges. Pressure gauges will enable the operator to monitor the pump performance and determine whether the pump conforms to the parameters of the performance curve. If cavitation, vapor binding, or other unstable operating situations occur, the pressure gauges will indicate wide fluctuation in the inlet and outlet pressures.

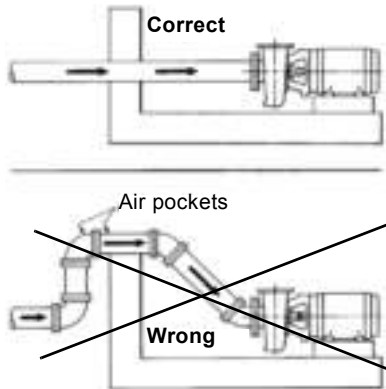

Fig. 3 Air pocket prevention

TM05 4792 2613

4.4.3 Outlet pipe

- A short outlet pipe can be the same diameter as the pump outlet port. A long outlet pipe must be one or two sizes larger than the outlet port, depending on the length.
- It is best to use long horizontal outlet pipes.
- Install a gate valve near the outlet port to be able to isolate the pump during shutdown and maintenance, and to facilitate pump removal.
- Any high points in the outlet pipe may entrap air or gas and thus retard pump operation.
- If water hammer occurs, i.e. if check valves are used, close the outlet gate valve before pump shutdown.

4.4.4 Shaft seals

The pumps are available with both stuffing boxes with packing rings and mechanical shaft seals.

Stuffing boxes

The stuffing boxes are normally packed before shipment.

If the pump is installed within 60 days after shipment, the packing material will be in good condition for operation with a sufficient supply of lubricating liquid.

If the pump is stored for more than 60 days, it may be necessary to repack the stuffing boxes.

The stuffing box must be supplied at all times with a source of clean, clear liquid to flush and lubricate the packing rings.

Packing gland adjustment

With the pump running, adjust the packing gland to permit a leakage of 40 to 60 drops per minute for shaft lubrication. After initial startup, additional packing and adjustment may be required.

Mechanical shaft seals

Mechanical shaft seals require no maintenance or adjustment.

End suction pumps equipped with mechanical shaft seals are matched to the operating conditions for which the pump was sold. Observe the following precautions to avoid shaft seal damage and to obtain maximum shaft seal life:



Do not run the pump dry or against a closed valve. Dry running will cause shaft seal failure within minutes.



Do not exceed the temperature or pressure limitations for the mechanical shaft seal used.

Clean and purge the inlet pipe in new installations before installing and operating pump. Pipe scale, welding slag and other abrasives can cause rapid shaft seal failure.

4.4.5 Coupling alignment of LF pumps

The pump and motor were accurately aligned from factory, but handling during shipment usually alters this pre-alignment.

1. If the pump and motor were shipped mounted on a common base frame as an assembly, remove the coupling guard.

2. Checking parallel alignment

Place a straight edge across both coupling rims at the top, the bottom and both sides. See fig. 4. After each adjustment, recheck all features of alignment. Parallel alignment is correct when the measurements show that all points of the coupling faces are within ± 0.005 in. (0.127 mm) of each other.

If misalignment is detected, loosen the motor and shift or shim as necessary to re-align. Then re-tighten the anchor bolts. Always align the motor to the pump as pipe strain will occur if the pump is shifted. Never reposition the pump on the base frame.

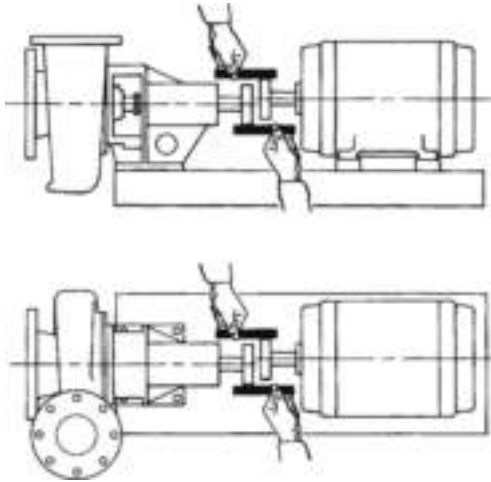

Fig. 4 Checking parallel alignment

3. Checking angular alignment

Insert a pair of inside callipers or a taper gauge at four points at 90° intervals around the coupling. See fig. 5. Angular alignment is correct when the measurements show that all points of the coupling faces are within ± 0.005 in. (0.127 mm) of each other.

– If misalignment is detected, loosen the motor and shift or shim as necessary to re-align. Then re-tighten the anchor bolts. Always align the motor to the pump as pipe strain will occur if the pump is shifted. Never reposition the pump on the base frame.

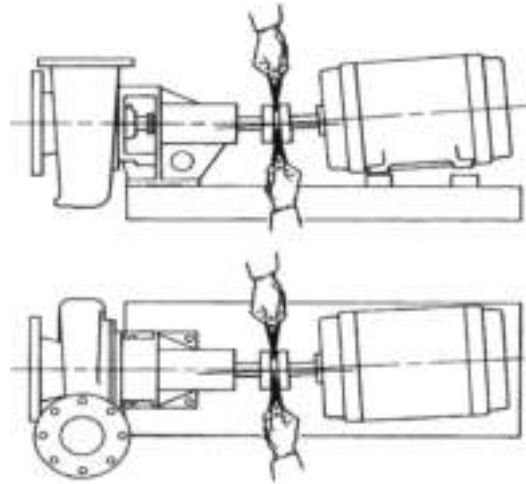

Fig. 5 Checking angular alignment

– Check shaft alignment once again after final pipe connections to the pump have been made, motor wiring verified, correct direction of rotation has been established, and pipes have been filled with liquid.

4. Leave the coupling guards off until the pump priming procedure has been completed.
5. Install the coupling guards after installation has been completed to protect personnel from rotating machinery.

Coupling alignment of LCS pumps

Alignment of the pump and motor is not required.

4.5 Electrical connection

DANGER

Electric shock

Death or serious personal injury

- The electrical installation must be carried out by a qualified electrician in accordance with local regulations and the manuals provided with the electrical accessories.



DANGER

Electric shock

Death or serious personal injury

- Before starting any work on the product, make sure that the power supply has been switched off and that it cannot be accidentally switched on.



TM05 4794 2613

TM05 4795 2613

4.5.1 Motors

The motor control circuit must include the following components in order to comply with the National Electrical Code:

Motor disconnecting device

- Install a motor disconnecting device that is capable of disconnecting both the controller (motor starter) and the motor from their source of power.
- Locate the disconnecting device in such a way that the controller (motor starter) can be seen from the disconnecting device. In all cases, the distance from the disconnecting device to the controller must be less than 50 ft (15.24 m).

In most installations, the disconnecting device will be a circuit breaker or fusible disconnect switch.

Motor short circuit and ground fault circuit interrupter

A short circuit and ground fault circuit interrupter is usually a circuit breaker or fusible disconnect switch.

- Select the circuit breaker or fuse in accordance with section 430-52 and table 430-152 of the National Electrical Code.

Motor controller with overcurrent protection (magnetic starter)

- Install these components in accordance with applicable local and state electrical codes in addition to the National Electrical Code.

DANGER

Explosive environment



Death or serious personal injury

- Observe the rules and regulations generally or specifically imposed by the relevant responsible authorities or trade organizations in relation to running powered equipment in an explosive environment.

4.5.2 Wiring

- Mount the control panel or the motor starter(s) close to the pump to provide convenient control and easy installation.
- Wire panel or starter(s) to motor(s) and pilot device(s). Wires to the motor(s) must be sized for at least 125 % of the motor nameplate full load amps. We recommend AWG #16 Type THW stranded wire for wiring of pilot devices, such as float switches.
- Check that the voltage, phase and frequency of the incoming power source correspond to the voltage, phase and frequency of the motor(s).
- Make sure that the starters are suitable for operating the pump motors on the voltage, phase and frequency available.

5. Starting up the product

5.1 Priming

End suction pumps are non-self-priming and must be completely primed, i.e. filled with liquid, before starting.

- If the pump will be operating with a positive inlet pressure, prime it by opening the inlet valve and allowing liquid to enter the pump housing. Open the air vents and make sure all air is forced out of the pump by the liquid before closing the air vents.
- Rotate the shaft by hand to free entrapped air from the impeller passageways.
- If the pump will be operating with a suction lift, priming must be accomplished by other methods. Use foot valves or ejectors, or fill the pump housing and the inlet line manually with liquid.



Never run the pump dry in the hope that it will prime itself. The result will be serious damage to the shaft seals, pump wear rings and shaft sleeves.

5.2 Pre-start checklist



Do not operate the product above the nameplate conditions. This may damage the product.

Make the following inspections before starting your L pump:

1. Make sure the inlet and outlet pipes have been cleaned and flushed to remove dirt and debris.
2. Double check the direction of rotation which must be clockwise. Operating in reverse will destroy the impeller and shaft.
3. Make sure all wiring connections to the motor and starting device are in accordance with the wiring diagram.
4. If the motor has been in storage for a long time, either before or after installation, refer to the motor instructions before starting.
5. Check the voltage, phase and frequency with the motor nameplate. Turn the impeller by hand to make sure it rotates freely.
6. Tighten the plugs in the gauge and drain holes. If the pump is fitted with pressure gauges, keep the gauge cocks closed when they are not in use.
7. Check the inlet and outlet pipes for leaks, and make sure all flange bolts are securely tightened.

5.3 Motor direction of rotation



Never check the motor direction of rotation unless the pump and motor couplings have been disconnected and physically separated. Failure to follow this instruction can result in serious damage to the pump and the motor if the direction of rotation is wrong.

After the product has been wired and checked to ensure that all components in the system, such as disconnect devices, magnetic starters, pilot devices and motors, are properly connected, check the motor direction of rotation as follows:

- For three-phase products only, momentarily energize the motor to ensure that the direction of rotation is correct as indicated by the arrow cast into the pump housing. If direction of rotation is incorrect, interchange two wires at the motor starter terminals T1 and T2.



The pumps must not be operated while dry. Use extreme caution that motors are energized only momentarily to determine proper direction of rotation.

5.4 Starting the pump

DANGER

Moving machine parts

Death or serious personal injury.

- Mount an approved coupling guard before operating the product.



- Install a coupling guard on coupled products.
- Fully open the gate valve (if any) in the inlet line, and close the gate valve in the outlet line.
- Fill the inlet line with liquid and completely prime the pump.
- Start the pump.
- Immediately make a visual check of the pump and inlet pipe for pressure leaks.
- Immediately after the pump has reached full operating speed, slowly open the outlet gate valve until complete system flow is achieved.
- Check the outlet pipe for pressure leaks.
- If the pump is fitted with pressure gauges, open gauge cocks and record pressure readings for future reference. Verify that the pump is performing in accordance with the parameters specified in the performance curves.
- Check and record voltage, amperage per phase, and kilowatts, if a wattmeter is available.

5.5 Voltage and frequency variation

The motor will operate satisfactorily under the following voltage and frequency variations, but not necessarily in accordance with the standards established for operation under rated conditions:

- The voltage variation must not exceed 10 % above or below the rating specified on the motor nameplate.
- The frequency variation must not exceed 5 % above or below the motor rating.
- The sum of the voltage and frequency variations must not exceed 10 % above or below the motor rating, provided the frequency variation does not exceed 5 %.

6. Storing and handling the product

See sections 3.3 *Temporary storage after delivery*, 9.2 *Short-time shutdown* and 9.3 *Long-term shutdown*.

7. Product introduction

7.1 Applications

We recommend the L pumps for these applications:

- commercial and industrial cooling systems
 - pumping both primary and secondary cooling water
- condenser water systems
- district cooling systems
- water distribution systems
- irrigation systems.

7.2 Pumped liquids

Clean, thin, non-aggressive liquids, not containing solid particles or fibers. Do not pump liquids that will attack the pump materials chemically.

7.3 Pump identification

All pumps are identified by catalog and serial numbers. These numbers are stamped on the pump nameplate, as shown in fig. 6, affixed to the pump housing. Refer to these numbers in all correspondence with Grundfos.

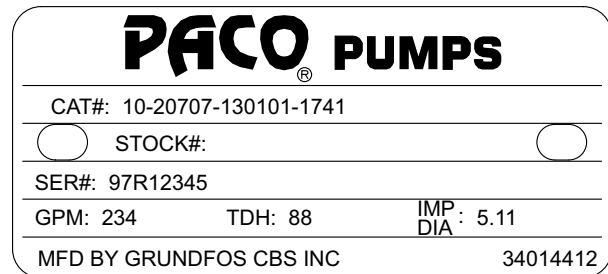

Fig. 6 Nameplate

TM06 6128 0616

8. Servicing the product

8.1 Maintaining the product

DANGER

Moving machine parts



Death or serious personal injury.

- Before any inspection, maintenance, service or repair of the product, make sure the motor controls are in the "OFF" position, locked and tagged.

8.2 Lubricating the product

8.2.1 Lubricating the motor

Always follow the motor manufacturer's lubricating instructions, if they are available, and periodically check grease fittings and drain plugs for leaks. If the lubricating instructions are not available, refer to the table below for recommended lubricating intervals.

- The motor can be lubricated both when it is running or when it is at rest.
Remove the grease drain plug, if any, and filler plug on the grease fitting. Grease with clean lubricant until grease appears at the drain hole or along the motor shaft.

Recommended lubricating intervals

Motor rpm	Motor hp	Operating conditions		
		Standard	Severe	Extreme
1750 and below	0.33 - 7.50	3 years	1 year	6 months
	10-40	1-3 years	6 months - 1 year	3 months
	50-150	1 year	6 months	3 months
above 1750	200 and up	1 year	6 months	3 months
	all hp	6 months	3 months	3 months

Standard conditions:

Operating 8 hours per day, normal or light load, clean air, 100 °F (37 °C) maximum ambient temperature.

Severe conditions:

Operating continuously 24-hours, shock loads or vibrations, poor ventilation, 100-150 °F (37-65 °C) ambient temperature.

Extreme conditions:

Operating continuously, heavy shocks or vibrations, dirt or dust in the air, extremely high ambient temperature.

One-half to one cubic inch (0.5³ - 1³ in.) of grease is sufficient for motors of 5 hp and lower, with proportionately more grease for bigger hp motors.

Most fractional and some integral frame motors have "sealed-for-life" bearings, and do not require further lubrication throughout motor life.

If lubricating instructions are not available, refer to the table *Recommended lubricating intervals* on page 11 for recommended lubrication periods.

The table *Approved grease lubricants* in section 8.2.2 *Lubricating the pump* lists the recommended types of grease for both pump and motor lubrication. These grease types have all been thoroughly tested and must be used whenever possible.

8.2.2 Lubricating the pump

Grease lubrication

In the standard configuration, LF pumps on horizontal base frames have sealed-for-life bearings. For customized pumps with regreasable bearings, use an approved grease and proceed as described below.

Approved grease lubricants

Manufacturer	Lubricant
Shell	Dolium® R
Exxon	Polyrex®
Chevron	SRI Grease NLGI 2
	Black Pearl - NLGI 2
Philips	Polytac™
Texaco	Polystar RB

- Remove the drain plug, if any, and the filler plug. Add clean lubricant until grease appears at the drain hole or along the pump shaft. On pumps with drain hole, all old grease can be purged. In such cases, the drain hole must be left unplugged for several minutes during pump operation to allow excess grease to be forced out.
- Lubricate the pump bearings at 1-3 month intervals, depending on the severity of the environment. Pumps in a clean, dry, moderate-temperature (100 °F (65 °C) maximum) environment must be regreased at 3-month intervals.



Do not over-grease! Too much grease can cause overheating and premature bearing failure.

Oil lubrication

LF pumps with oil lubricated bearings are fitted with a transparent reservoir, a constant-level oiler, that maintains the oil level about the centerline of the bearing. See fig. 7.

- Follow a regular oil maintenance program. When necessary, renew the oil supply in the reservoir of the constant-level oiler.
- Change the oil after the first 200 hours of operation. To change the oil, remove the drain plug at the bottom of the bearing cover and the filler plug, that also acts as a vent plug, at the top of the bearing frame. After draining the oil, replace the drain plug and refill the reservoir with an oil from the table *List of acceptable oil lubricants* on page 12. After the first oil change, the oil must be changed again at 2000 hours and then at intervals of 8000 hours or once a year, thereafter.

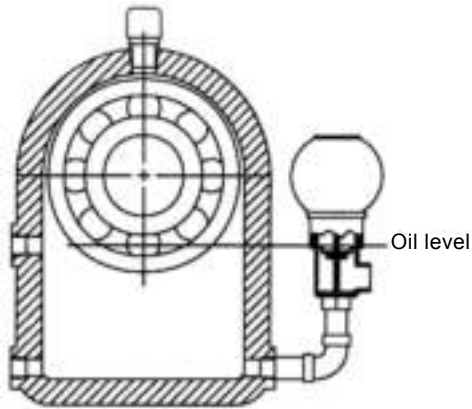

Fig. 7 Oil lubrication

TM05 4793 2613

List of acceptable oil lubricants

Lubricant manufacturer	Bearing oil brand name
Aral Refining Co.	Aral Oil CMU
	Aral Oil TU 518
British Petroleum Co.	BP Energol
	TH 100-HB
Calypsol Oil Co.	Calypsol Bison Oil
	SR 25 or SR 36
Standard Oil Co.	Chevron
	Hydraulic Oil 11
	Circulating Oil 45
Esso Corp	Esso-Mar 25
	Teresso 47
	Esstic 50
Fina Oil Co.	Fina Hydran 34
	Fina Cirkan 32
Gulf Refining Co.	Gulf Harmony 47
	Gulf Paramount 45
Socony Mobil Oil Co.	Vac hlp 25
	Mobulix D.T.E. 25
Shell Oil Co.	Shell Tellus Oil 29
Sundco Oil Co.	Sunvis 821
The Texas Co.	Texaco Ursa Oil P 20
	Dea Viscobil Sera 4

8.3 Disassembling the pump

8.3.1 Preparations before disassembling the pump

DANGER

Electric shock

Death or serious personal injury.

- Before starting any work on the product, make sure that the power supply has been switched off and that it cannot be accidentally switched on.



CAUTION

Toxic material

Minor or moderate personal injury.

- Wash down the pump before doing any work on it.



DANGER

Hot, caustic, flammable or toxic materials, including vapors

Death or serious personal injury.

- Be extremely cautious when venting and/or draining hazardous liquids. Wear protective clothing when there are caustic, corrosive, volatile, flammable, or hot liquids. Do not breathe toxic vapors. Do not allow sparks, open fire, or hot surfaces near the equipment.



Complete disassembly instructions are outlined below. Proceed only as far as required to perform the maintenance work needed.

1. Switch off the power supply.
2. Drain the system.
3. Flush the system, if necessary.
4. For close-coupled pumps: Remove the motor fixation bolts.

8.3.2 Disassembling the pump

1. Remove the pump housing screws (8B).
2. Remove the back pull-out bearing frame (20Y) from the pump housing (1A).
3. Remove the impeller screw (8A).
If necessary, use a strap wrench around the impeller or shaft to prevent rotation.

WARNING



Moving machine parts

Death or serious personal injury.

- Do not insert a screwdriver between the impeller vanes to prevent rotation.

4. Use an appropriately sized puller aligned behind the impeller vanes to remove the impeller (3A) from the shaft (6A).
5. Remove the impeller key (12A).
6. Remove the back plate screws (8D). Remove the back plate (2K) and the seal housing (26P).
7. Place the seal housing on a flat surface and press out the shaft seal (14A).
8. If the shaft sleeve (5A) requires replacement, heat it evenly to approximately 350 °F (176 °C) to loosen the thread-locking fluid. Twist the sleeve off the shaft (6A).

8.3.3 Disassembling the bearing frame (LF)

1. Remove the slinger (13G).
2. Remove the lip seal(s) (14S), if any.
3. Remove the bearing housing locking ring (61K).
4. Press or tap on the pump end of the bearing-shaft assembly until one bearing is out.
5. When one bearing is out, remove the second locking ring (61F), then remove the complete bearing-shaft assembly from bearing housing.
6. Remove the shaft locking ring (61C) and press off the bearings.
7. Press new bearings on to the shaft; remember to press only on the inner race of the bearings while pressing them on.
8. Assemble the bearing frame in the reverse procedure used for disassembling.
9. Observe the following when reassembling the bearing frame:
 - Replace the lip seals (14S) if they are worn or damaged.
 - Replace the bearings (18A) and (18B) if they are loose, rough or noisy when rotated.
 - Check the shaft (6A) for shaft runout at the shaft sleeve (5A) area. Maximum permissible runout is 0.002 in. (0.05 mm) total indicator runout.

8.4 Replacing the shaft seal (LCS pumps)

1. Complete the preparations listed in section 8.3 *Disassembling the pump*.
2. Remove the coupling guard screws (8E).
3. Remove the coupling guard (34F).
4. Remove the nut (35E) and the bolt (8E) that hold the coupling halves together.
5. Pry apart the coupling halves (23D), remove the coupling key (12B).



Mark or measure the original position of the pump coupling on the motor side.

6. Unscrew the tubing connector from the pipe tee of the air vent assembly. Thread sealing compound was applied to the threads during factory assembly, and the resulting bond may retard but will not prevent manual disassembling.
7. Remove the seal housing cap screws and slide the seal housing (2N) up the shaft to remove it.
8. Remove the shaft seal manually from the shaft (6A). Apply water-soluble lubricant to the shaft, if necessary, to ease the removal of the shaft seal (14A). Pull the shaft seal manually from the shaft, using a slight twisting motion (as necessary) to loosen the bellows from the shaft.
9. Remove and discard the shaft seal spring and the shaft seal retainer.
10. Remove and discard the shaft seal seat from the seal housing (2N) and thoroughly clean the inside cavity of the seal housing.
11. The interior surface of the bellows on a new shaft seal is coated with a bonding agent that adheres to the motor shaft. When the old shaft seal is removed, the bonding agent no longer exists and the bellows may crack or split during removal. We always recommend that you install a new mechanical shaft seal if it becomes necessary to remove the existing shaft seal from the shaft.
12. Clean and lubricate the shaft (6A) with a water-soluble lubricant and make sure no sharp edges can cut or scratch the bellows of the new shaft seal.
13. Press the new shaft seal seat firmly into the seal housing. Avoid direct contact between the seal face and metallic or abrasive objects, and wipe the seal face clean after installation to ensure an abrasive-free sealing surface.
14. Slide the new shaft seal onto the shaft by applying even pressure to the shaft seal.
15. Install the shaft seal housing (2N) on the shaft.
16. See the reassembly instructions in section 8.6 *Reassembling the pump*.

8.5 Replacing the wear ring

1. Complete the preparations in sections *8.3.1 Preparations before disassembling the pump* and *8.3.2 Disassembling the pump*.
2. Remove the rotating assembly.
3. Remove the pump housing (1A) from the pipes, if necessary, to facilitate easy access to the interior of the pump housing. If necessary, remove the flange bolts at the pipes.
4. Remove a worn wear ring (4A) by drilling two holes slightly smaller than the width of the wear ring into the exposed edge of the wear ring. Insert a chisel into the holes to completely sever the wear ring at the holes and break the wear ring into two halves for easy removal.
5. Clean the wear ring cavity in the pump housing prior to installing a new wear ring to ensure a properly aligned fit.
6. To reassemble, press fit the new wear ring squarely into the pump housing cavity. Tap the wear ring into place to make sure it is pressed home into the cavity.



Do not use metal tools on the wear ring surfaces. Use only rubber, rawhide, wood or other soft material to prevent damage to the wear ring.

8.6 Reassembling the pump

1. Clean all parts before reassembly.
2. Refer to the parts list to identify required replacement items. Specify the pump serial or catalog number when ordering parts.
3. Reassemble the pump in the reverse procedure used for disassembling.
4. Observe the following when reassembling the pump:
 - All mechanical seal components must be in good condition or leakage may result. We recommend that you replace the complete shaft seal.
 - Install new shaft sleeves by bonding them to the shaft with a thread-locking fluid.
5. Re-install the coupling guards on coupled pumps.

8.7 LF, exploded view and parts list

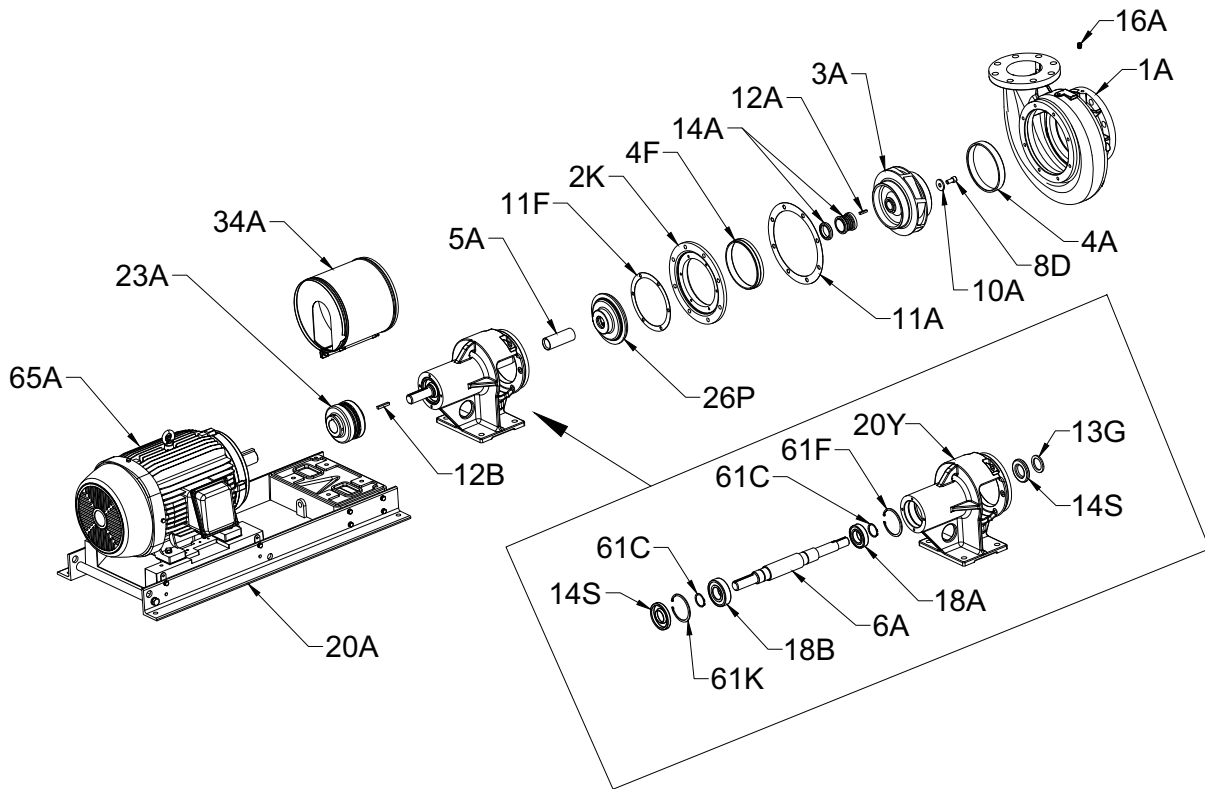

TM06 6487 1416

Pos.	Description
1A	Pump housing
2K	Back plate
3A	Impeller
4A	Wear ring
4F*	Balance wear ring
5A	Shaft sleeve
6A	Shaft
8D	Cap screw
10A	Washer
11A	Gasket
11F	Gasket
12A	Key
12B	Key
13G	Slinger

Pos.	Description
14A	Shaft seal
14S	Lip seal
16A	Drain plug
18A	Bearing, inboard
18B	Bearing, outboard
20A	Baseplate
20Y	Bearing frame
23A	Coupling hub
26P	Seal housing
34A	Coupling guard
61C	Locking ring
61F	Locking ring
61K	Locking ring
65A	Motor

* If applicable

8.8 LC, cross section and parts list

Pump with shaft seal

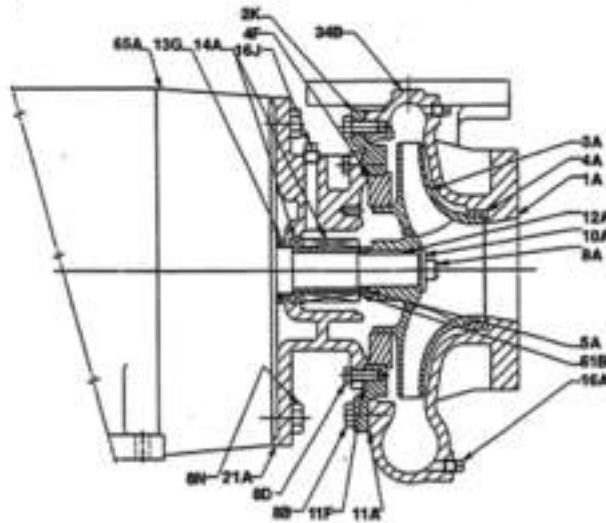

Pump with stuffing box

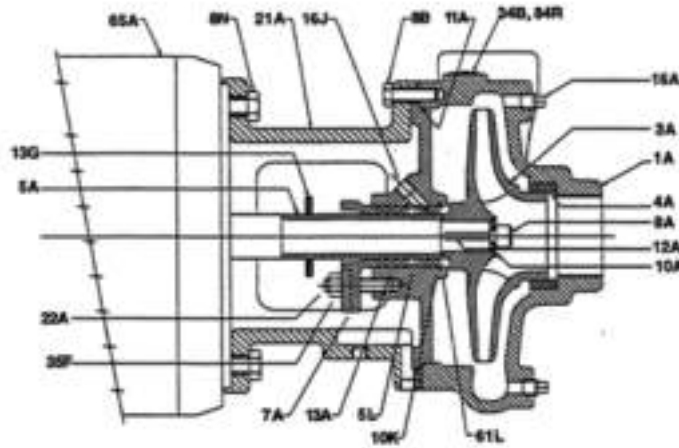

TM05 8911 2913

Pos.	Description
1A*	Pump housing
2K**	Back plate
3A	Impeller
4A	Wear ring
4F	Wear ring
5A	Shaft sleeve
5L*	Distribution ring
7A*	Stuffing box gland
8A	Cap screw
8B	Cap screw
8D	Cap screw
8N	Cap screw
10A	Washer
10K*	Washer
11A	Gasket

Pos.	Description
11F**	Gasket
12A	Key
13A*	Stuffing box
13G	Slinger
14A**	Mechanical shaft seal
16A	Drain plug
16J*	Plug
21A	Motor stool
22A*	Stud
34B	Nameplate
35F*	Nut
61B	Locking ring
61L*	Locking ring
65A	Motor
84R	Screws

* Pumps with stuffing box only

** Pumps with shaft seal only

8.9 LCV, cross section and parts list

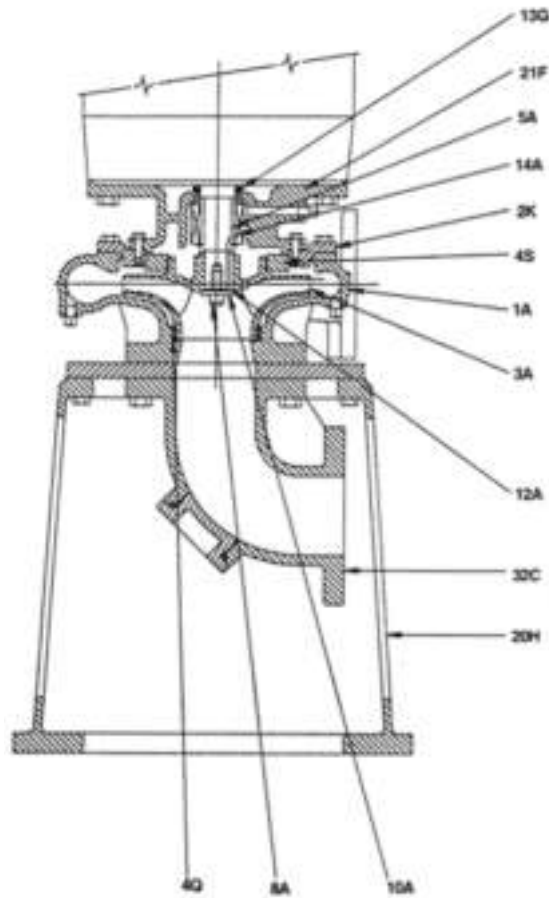

TM05 8910 2913

Pos.	Description
1A	Pump housing
2H	Hand hole cover (not shown)
2K	Back plate
3A	Impeller
4Q	Wear ring
4S	Wear ring
5A	Shaft sleeve
8A	Cap screw

Pos.	Description
10A	Washer
12A	Key
13G	Slinger
14A	Single mechanical shaft seal
20H	Stand
21F	Motor stool
32C	Elbow with cleanout port

8.10 LCS, exploded view and parts list

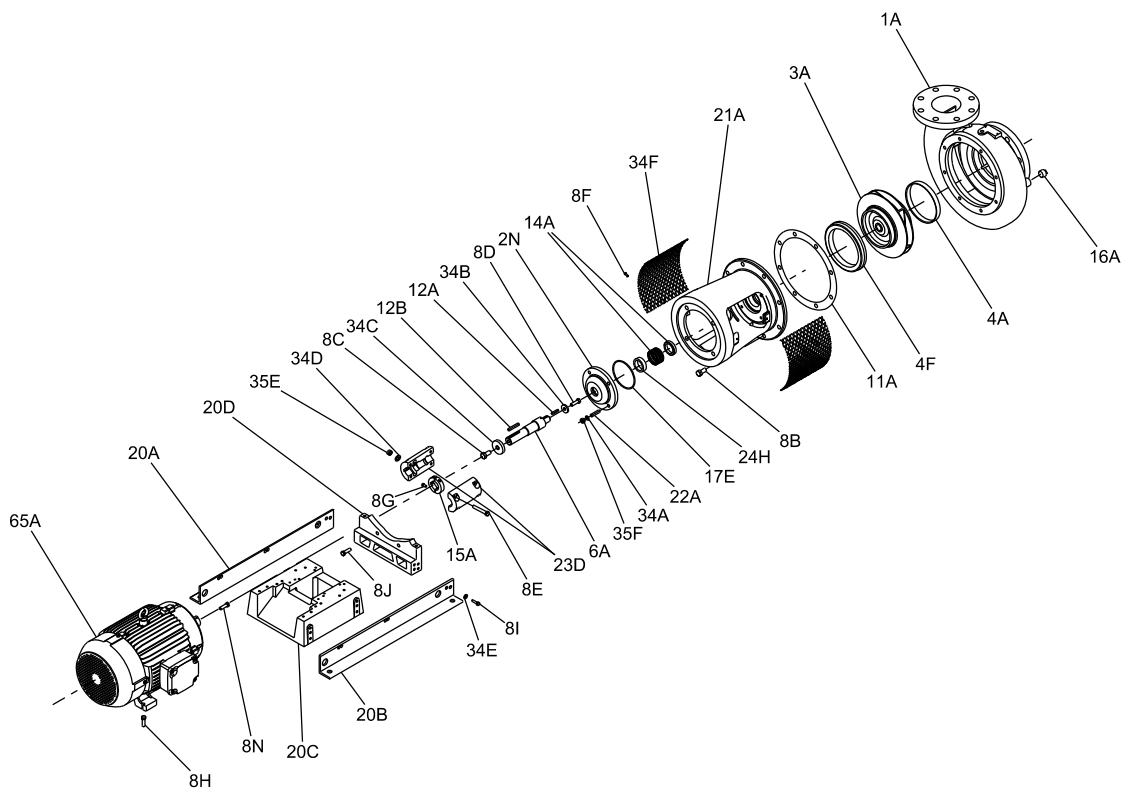

TM06 4374 2115

Pos.	Description
1A	Pump housing
2N	Shaft seal housing
3A	Impeller
4A	Wear ring
4F	Balance wear ring
6A	Pump shaft
8B	Cap screw
8C	Screw
8D	Screw
8E	Bolt
8F	Screw
8G	Screw
8H	Cap screw
8I	Cap screw
8J	Cap screw
8N	Screw
11A	Gasket
12A	Key
12B	Key
14A	Shaft seal

Pos.	Description
15A	Locating ring
16A	Drain plug
17E	O-ring
20 A + 20B	Base plate profile
20C	Base plate
20D	Pump support
21A	Motor stool
22A	Stud
23D	Coupling halves
24H	Bushing
34A	Washer
34B	Washer
34C	Washer
34D	Washer
34E	Washer
34F	Coupling guard
35E	Nut
35F	Nut
65A	Motor

9. Taking the product out of operation

The following shutdown procedures will apply for the L pumps in most normal shutdown situations. If the pump will be inoperative for a long time, follow the storage procedures in section 9.3 *Long-term shutdown*.

9.1 General procedure

- Always close the outlet gate valve before stopping the pump. Close the valve slowly to prevent hydraulic shock.
- Switch off and lock off the power supply to the motor.

9.2 Short-time shutdown

- For overnight or temporary shutdown periods under non-freezing conditions, the pump may remain filled with liquid. Make sure the pump is fully primed before restarting.
- For short or frequent shutdown periods under freezing conditions, keep the liquid moving within the pump housing and insulate or heat the pump exterior to prevent freezing.

9.3 Long-term shutdown

- For long shutdown periods, or to isolate the pump for maintenance, close the inlet gate valve. If no inlet valve is used and the pump has positive inlet pressure, drain all liquid from the inlet line to stop the liquid flow into the pump inlet. Remove the plugs in the pump drain and vent holes, as required, and drain all liquid from the pump housing.
- If there will be freezing conditions during long shutdown periods, completely drain the pump and blow out all liquid passages and pockets with compressed air. Freezing of the pumped liquid can also be prevented by filling the pump with antifreeze solution.

10. Fault finding



DANGER

Electric shock

Death or serious personal injury.

- Before starting any work on the product, make sure that the power supply has been switched off and that it cannot be accidentally switched on.



CAUTION

Toxic material

Minor or moderate personal injury.

- Wash down the pump before doing any work on it.



DANGER

Hot, caustic, flammable or toxic materials, including vapors

Death or serious personal injury.

- Be extremely cautious when venting and/or draining hazardous liquids.
- Wear protective clothing when there are caustic, corrosive, volatile, flammable, or hot liquids.
- Do not breathe toxic vapors.
- Do not allow sparks, open fire, or hot surfaces near the equipment.

Fault	Cause	Remedy
1. Outlet pressure is too low.	a) The speed of rotation is too low.	Reestablish correct speed and direction of rotation.
	b) The system pressure is lower than anticipated.	Check the system curve.
	c) There is air or gas in the pumped liquid.	Remove the air from the pumped liquid.
	d) The wear rings are worn.	Replace the wear rings.
	e) The impeller is damaged.	Repair or replace the impeller.
	f) The impeller diameter is too small.	Replace the impeller with one of the correct diameter.
	g) Wrong direction of rotation.	Interchange two wires in the power supply.
	h) The pump has lost its prime.	Re-prime the pump.
	i) There is insufficient NPSH.	Restore required NPSH.
	j) Passages are restricted.	Clean the impeller and pump housing passages.
	k) Joints or the stuffing box are leaking.	<ul style="list-style-type: none"> • Tighten the joints or the stuffing box gland. • Replace the shaft sleeve. • Replace the gaskets.
2. Insufficient inlet pressure.	a) The inlet line is drawing air.	Tighten the connections.
	b) The suction lift is too high or there is insufficient NPSH.	Reduce the suction lift or restore required NPSH.
	c) Air or gas is trapped in the pumped liquid.	Remove the trapped air or gas from liquid.
	d) The strainer is clogged.	Clean the strainer.
3. Noise level has increased.	a) Poor alignment of the pump. Inlet and outlet pipe clamps are loose.	<ul style="list-style-type: none"> • Reestablish proper alignment of the pump and the motor. • Support the inlet and outlet pipes. • Make sure the vibration dampers, flexible pipes and conduit connectors are installed correctly.
	b) Cracked foundation.	Repair the foundation.
	c) Worn ball bearings.	<ul style="list-style-type: none"> • Replace the worn bearings. • Renew the lubrication.
	d) The motor is unbalanced.	<ul style="list-style-type: none"> • Disconnect the motor and operate it alone. • Remove large pieces of debris, such as wood or rags from the pump. • Clean out the pump, if necessary.
	e) Hydraulic resonance.	<ul style="list-style-type: none"> • Alter the resonant pipes. • Change the pump speed. • Insert a pulsation damper on the pump or the pipes. • Insert a flow straightener.

Fault	Cause	Remedy
4. Insufficient flow.	a) The pump is not primed.	Prime the pump.
	b) The system pressure exceeds the shut off pressure.	<ul style="list-style-type: none"> • Increase the liquid level on the inlet side. • Open the isolating valve in the inlet pipe.
	c) The speed of rotation is too low.	Reestablish the correct speed of rotation.
	d) The suction lift is too high or there is insufficient NPSH.	Reduce the suction lift or restore required NPSH.
	e) The strainer or the impeller is clogged.	Clean the strainer and the impeller passages.
	f) Wrong direction of rotation.	Reestablish the correct direction of rotation.
	g) Leaking joints.	Tighten the joints.
	h) Broken shaft or coupling	Repair or replace damaged parts.
	i) Closed inlet valve.	If the inlet valve is closed, open it slowly.
	j) There is not enough inlet pressure for hot or volatile liquids.	Reestablish required inlet pressure.
	k) Foot valve is too small.	Replace the foot valve.
	l) Worn or damaged hydraulic parts.	Repair or replace the worn parts.
	m) Excessive clearance between the wear surfaces.	See section 8.5 <i>Replacing the wear ring</i> .
5. The pump loses its prime after starting.	a) Joints or the stuffing box are leaking.	<ul style="list-style-type: none"> • Tighten the joints or the stuffing box gland. • Replace the shaft sleeve. • Replace the gaskets.
	b) The suction lift is too high or there is insufficient NPSH.	Reduce the suction lift or restore required NPSH.
6. Excessive power required.	a) The speed of rotation is too high.	Reduce the speed of rotation.
	b) The pump is operating beyond its recommended performance range.	Set the duty point in accordance with the recommended performance range.
	c) The specific gravity or viscosity of the pumped liquid is too high.	If less flow is sufficient, reduce the flow on the outlet side, or fit the pump with a more powerful motor.
	d) The shaft is bent.	Replace the shaft.
	e) The stuffing-box is too tight.	Retighten the stuffing box if possible. Alternatively, repair or replace the stuffing box.
	f) The impeller clearance is too small causing rubbing or worn wear surfaces.	Adjust the impeller clearance, if possible, or replace the wear ring.
	g) There is an electrical or mechanical defect in the motor.	Contact your local service center for diagnostics.
	h) The pump is restricted in its rotation.	Remove any obstacles or replace any worn parts.
	i) Incorrect lubrication of the motor.	Reestablish correct lubrication of the motor.

11. Technical data

11.1 Operating conditions

11.1.1 Flow rate

Minimum flow rate

The pump must not run against closed outlet valve as this will cause an increase in temperature or formation of steam in the pump.

This may cause shaft damage, impeller erosion, short life of bearings, damage to stuffing boxes or mechanical shaft seals due to stress or vibrations.

The minimum continuous flow rate is shown when selecting the pump in Grundfos Express online selection tool.

Maximum flow rate

The maximum flow rate must not exceed the value stated on the nameplate. If the maximum flow rate is exceeded, cavitation and overload may occur.

11.1.2 Ambient temperature and altitude

The ambient temperature and the installation altitude are important factors for the motor life, as they affect the life of the bearings and the insulation system.

Too high ambient temperature or low density and consequently low cooling effect of the air may result in overheating.

In such cases, it may be necessary to use a motor with a higher output.

11.1.3 Liquid temperature

The maximum liquid temperature depends on the material of the mechanical shaft seal, O-rings and gaskets used:

- Temperature range for BUNA:
32-212 °F (0-100 °C).
- Temperature range for FKM:
59-275 °F (15-135 °C).
- Temperature range for EPDM:
59-275 °F (15-135 °C).

11.1.4 Outlet pressure

Maximum outlet pressure

The maximum outlet pressure is the pressure (total dynamic head or TDH) stated on the pump nameplate.

11.1.5 Inlet pressure

Minimum inlet pressure

The minimum inlet pressure must correspond to the NPSH curve for the pump + a safety margin of minimum 1.6 ft (0.5 m) head.

Pay attention to the minimum inlet pressure to avoid cavitation.

The risk of cavitation is higher in the following situations:

- The liquid temperature is high.
- The flow rate is considerably higher than the pump's rated flow rate.
- The pump is operating in an open system with suction lift.
- The inlet conditions are poor.
- The operating pressure is low.

Maximum inlet pressure

Inlet pressure + pump pressure must be lower than maximum pressure (total dynamic head or TDH) of the pump.

12. Disposing of the product

This product or parts of it must be disposed of in an environmentally sound way:

1. Use the public or private waste collection service.
2. If this is not possible, contact the nearest Grundfos company or service workshop.

Subject to alterations.

Grundfos CBS Inc.

902 Koomey Road
Brookshire, TX 77423 USA
Phone: 281-994-2700
Toll Free: 1-800-955-5847
Fax: 1-800-945-4777

www.grundfos.us

GRUNDFOS Canada

2941 Brighton Road
Oakville, Ontario L6H 6C9 Canada
Phone: +1-905 829 9533
Telefax: +1-905 829 9512

www.grundfos.ca

GRUNDFOS México

Boulevard TLC No. 15
Parque Industrial Stiva Aeropuerto
C.P. 66600 Apodaca, N.L. México
Phone: 011-52-81-8144 4000
Fax: 011-52-81-8144 4010

www.grundfos.mx

99327137 0817

ECM: 1214834

© Copyright Grundfos Holding A/S

The name Grundfos, the Grundfos logo, and **be think innovate** are registered trademarks owned by Grundfos Holding A/S or Grundfos A/S, Denmark. All rights reserved worldwide.