

GENERAL NOTES

- ① - PUMP INCLUDES INTEGRATED FREQUENCY CONVERTER AND IS NSF/ANSI 61 CERTIFIED FOR DRINKING WATER.
- ② - INLET AND DISCHARGE BOTH USE THREADED NPT CONNECTIONS. ENSURE CONNECTIONS DO NOT PUT ANY STRAIN ON THE PUMP.
- ③ - FIVE WAY FITTING WITH INTEGRATED NON-RETURN VALVE.
- ④ - FACTORY INSTALLED PRESSURE GAUGE WITH RANGE OF 0-145 PSI.
- ⑤ - FACTORY INSTALLED PRESSURE SENSOR.
- ⑥ - FACTORY INSTALLED DIAPHRAGM EXPANSION TANK
- ⑦ - FACTORY INSTALLED FRAME MOUNT, ENSURE PUMP IS INSTALLED ON A FLAT HORIZONTAL SURFACE. NO HOUSEKEEPING PAD NEEDED BUT GENERALLY RECOMMENDED.

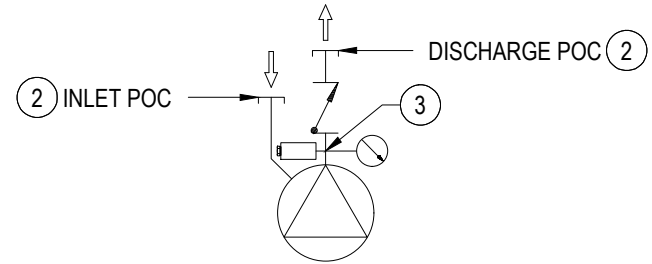

1 CMBE SIMPLEX BOOSTER PUMP DETAIL AND SCHEMATIC
SCALE: NTS

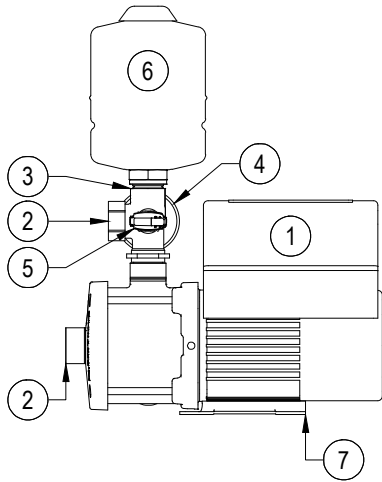
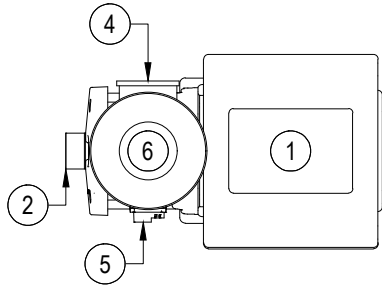

DRAWING TITLE:
GRUNDFOS CMBE SIMPLEX BOOSTER DETAIL
AND SCHEMATIC

DRAWING NUMBER:
010.A

DRAWN BY BM	LAST REVISED 01.24.2022	DRAWING SCALE NTS
----------------	----------------------------	----------------------

THE DOCUMENT AND ALL INFORMATION SHOWN IS PROPERTY OF HURLEY ENGINEERING, INC. THIS DOCUMENT IS NOT TO BE REDISTRIBUTED OR COPIED OR USED FOR THE MANUFACTURING OF EQUIPMENT WITHOUT PRIOR WRITTEN CONSENT FROM HURLEY ENGINEERING, INC.

QR CODE

